

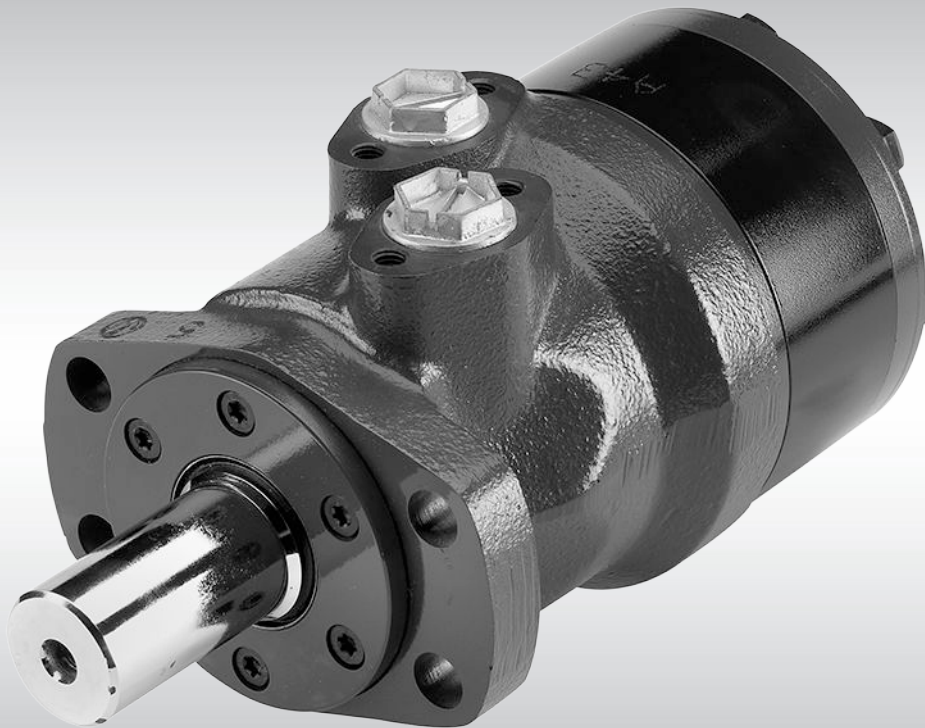

Technical Information

Orbital Motors

Type OMP, OMR and OMH



Revision history*Table of revisions*

Date	Changed	Rev
November 2014	Converted to Danfoss layout - DITA CMS	DA
Nov 2012	Planetary Gears deleted	CF
Sep 2011	Typo	CE
Sep 2010	New back cover	CD
Mar 2010	Japan location	CC
Jun 2007	Major revision with new lit-number (minus OMEW, will be prepared separately)	CA
Mar 2006	Small updates	B

Technical Information Orbital Motors Type OMP, OMR and OMH

Contents
A Wide Range of Hydraulics Motors

A Wide Range of Hydraulic Motors.....	6
Survey of Literature with Technical Data on Danfoss Hydraulic Motors.....	7
Speed, Torque and Output.....	8

Versions

Versions.....	9
Features available (options).....	9

Code Numbers

Code Numbers.....	10
-------------------	----

Technical Data

Technical data for OMP with 25 mm and 1 in cylindrical shaft.....	11
Technical data for OMP with 1 in splined and 28.5 mm tapered shaft.....	12
Technical data for OMP with 32 mm cylindrical shaft.....	13

Technical Data - Max. Permissible Shaft Seal Pressure

OMP with HIGH Pressure Shaft Seal (HPS).....	15
OMP with Standard Shaft Seal.....	15

Technical Data

Pressure Drop in Motor.....	17
Oil flow in drain line.....	17
Direction of Shaft Rotation.....	17
Permissible Shaft Load for OMP N.....	18
Permissible Shaft Load for OMPW with Slide Bearings.....	19
Permissible Shaft Load for OMPW N with Needle Bearing.....	19

Function Diagrams

Function Diagrams.....	21
OMP 60 under preparation	22
OMP 110 under preparation.....	23

Shaft Version

Shaft Version.....	25
--------------------	----

Port Thread Versions

Port Thread Versions.....	27
Manifold Mount.....	27

Dimensions - European Version

Dimensions.....	28
-----------------	----

Dimensions - US Version

Dimensions.....	32
-----------------	----

Dimensions - European Version

Dimensions.....	33
-----------------	----

Dimensions - US Version

Dimensions.....	35
-----------------	----

Dimensions - European Version

Dimensions.....	37
-----------------	----

Versions

Versions.....	39
Features available (options).....	40

Code Numbers

Code Numbers.....	41
-------------------	----

Technical Data

Technical data for OMR with 25 mm and 1 in cylindrical shaft.....	42
Technical data for OMR with 1 in splined and 28.5 mm tapered shaft.....	42
Technical data for OMR with 32 mm , 1 ¼ in cylindrical shaft and 35 mm, 1 ¼ in tapered shaft.....	43

Technical Information Orbital Motors Type OMP, OMR and OMH

Contents

Technical Data for Parking Brake Motor OMR F, OMR NF and OMRW NF.....	44
Function.....	44
Technical Data - Max. Permissible Shaft Seal Pressure	
OMR with High Pressure Shaft Seal (HPS).....	46
OMR with Standard Shaft Seal.....	46
Technical Data	
Pressure Drop in Motor.....	48
Oil flow in drain line.....	48
Direction of Shaft Rotation.....	48
Permissible Shaft Loads for OMR.....	48
Permissible Shaft Load for OMR N and OMR NF with Needle Bearings.....	49
Permissible Shaft Load for OMRW N and OMRW NF with Needle Bearings.....	50
Function Diagrams	
Function Diagrams.....	51
Shaft Version	
Shaft Version.....	54
Port Thread Versions	
Port Thread Versions.....	58
Manifold Mount.....	58
Dimensions-European version	
Dimensions.....	59
Dimension-US Version	
Dimensions.....	65
Dimensions-European Version	
Dimensions.....	67
Dimensions-US Version	
Dimensions.....	69
Dimensions-European Version	
Dimensions.....	71
Dimensions-US Version	
Dimensions.....	73
Dimensions-European Version	
Dimensions.....	75
Dimensions-US Version	
Dimensions.....	76
Dimensions-European Version	
Dimensions.....	77
Dimensions-US Version	
Dimensions.....	78
Dimensions-European Version	
Dimensions.....	79
Version	
Versions.....	81
Code Numbers	
Code Numbers.....	82
Technical Data	
Technical data for OMH with 1 in SAE 6 B splined shaft.....	83
Technical data for OMH with 32 mm and 1 1/4 in cylindrical shaft.....	83
Technical data for OMH with 35 mm cylindrical, 1 1/4 in splined and 35 mm tapered shaft.....	84

Technical Information Orbital Motors Type OMP, OMR and OMH

Contents

Max. Permissible Shaft Seal Pressure.....	85
Pressure Drop in Motor.....	86
Oil Flow in Drain Line.....	86
Direction of Shaft Rotation.....	87
Permissible Shaft Loads for OMH.....	87

Function Diagrams

Function Diagrams.....	88
------------------------	----

Shaft Version

Shaft Version.....	90
--------------------	----

Technical Data

Port Thread Versions.....	93
Manifold Mount.....	94

Dimensions-European Version

Dimensions.....	95
-----------------	----

Dimensions-US Version

Dimensions.....	96
-----------------	----

Weight of motors

Weight of Motors.....	97
-----------------------	----

A Wide Range of Hydraulics Motors

A Wide Range of Hydraulic Motors

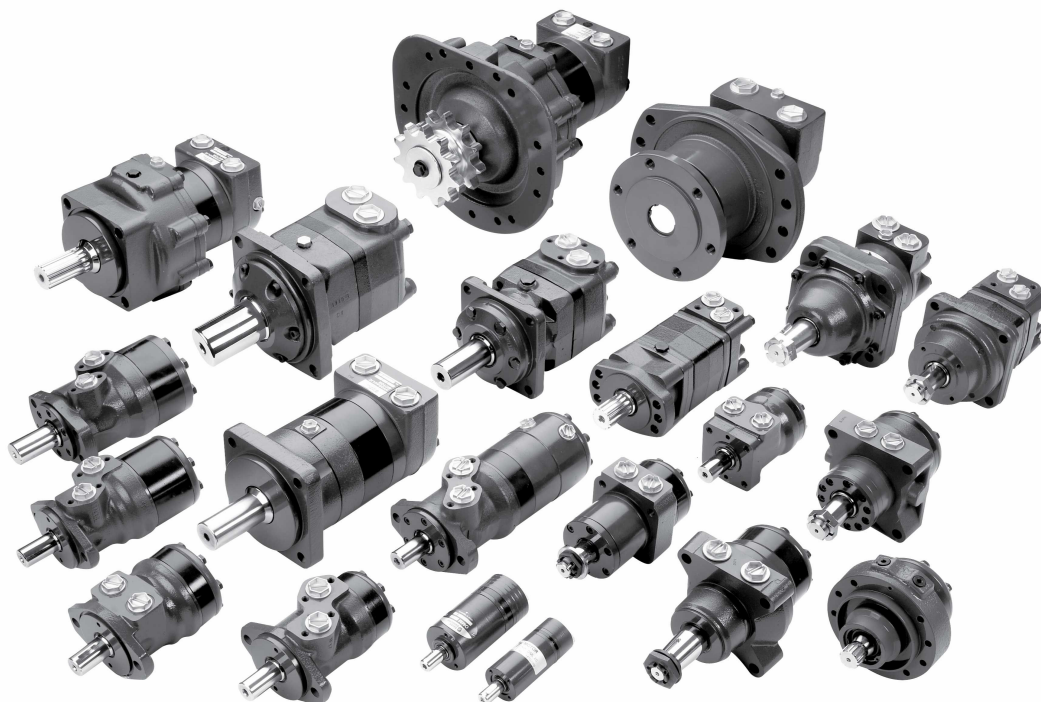

Danfoss is a world leader within production of low speed hydraulic motors with high torque. We can offer more than 3000 different hydraulic motors, categorised in types, variants and sizes (incl. different shaft versions).

The motors vary in size (rated displacement) from 8 cm³ [0.50 in³] to 800 cm³ [48.9 in³] per revolution.

Speeds range up to approx. 2500 min⁻¹ (rpm) for the smallest type and up to approx 600 min⁻¹ (rpm) for the largest type.

Maximum operating torques vary from 13 Nm [115 lbf-in] to 2700 Nm [24.000 lbf-in] (peak) and maximum outputs are from 2.0 kW [2.7 hp] to 70 kW [95 hp].

Characteristic features:

- Smooth running over the entire speed range
- Constant operating torque over a wide speed range
- High starting torque
- High return pressure without the use of drain line (High pressure shaft seal)
- High efficiency
- Long life under extreme operating conditions
- Robust and compact design
- High radial and axial bearing capacity
- For applications in both open and closed loop hydraulic systems
- Suitable for a wide variety of hydraulics fluids

The programme is characterised by technical features appealing to a large number of applications and a part of the programme is characterised by motors that can be adapted to a given application. Adaptions comprise the following variants among others:

A Wide Range of Hydraulics Motors

- Motors with corrosion resistant parts
- Wheel motors with recessed mounting flange
- OMP, OMR- motors with needle bearing
- OMR motor in low leakage version
- OMR motors in a super low leakage version
- Short motors without bearings
- Ultra short motors
- Motors with integrated positive holding brake
- Motors with integrated negative holding brake
- Motors with integrated flushing valve
- Motors with speed sensor
- Motors with tacho connection
- All motors are available with black finish paint

The Danfoss LSHT motors are used in the following application areas:

- Construction equipment
- Agricultural equipment
- Material handling & Lifting equipment
- Forestry equipment
- Lawn and turf equipment
- Special purpose
- Machine tools and stationary equipment
- Marine equipment

Survey of Literature with Technical Data on Danfoss Hydraulic Motors

Detailed data on all Danfoss motors can be found in our motor catalogue, which is divided into 8 individual subcatalogues:

- General information on Danfoss hydraulic motors: function, use, selection of hydraulic motor, hydraulic systems, etc.
- Technical data on small motors: OML and OMM
- Technical data on medium sized motors: OMP, OMR and OMH
- Technical data on medium sized motors: DH and DS
- Technical data on medium sized motors: OMEW
- Technical data on large motors: OMS, OMT and OMV
- Technical data on large motors: TMK
- Technical data on large motors: TMT
- Technical data on large motors: TMVW

A general survey brochure on Danfoss hydraulic motors gives a quick motor reference based on power, torque, speed and capabilities.

A Wide Range of Hydraulics Motors

Speed, Torque and Output

Max. speed, Max. torque, Max. output

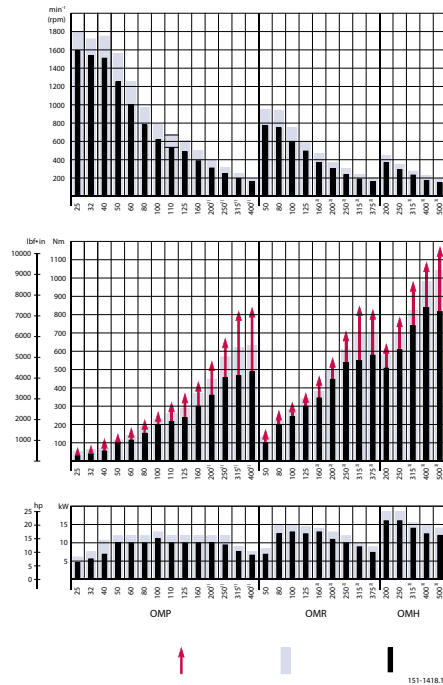

Peak value, Intermittend values, Continuous values

1. 1 1/4 in shaft
2. 1 1/4 in or 1 1/4 in tapered shaft
3. 1 1/4 in splined shaft

The bar diagrams above are useful for a quick selection of relevant motor size for the application. The final motor size can be determined by using the function diagram for each motor size.

- OMP and OMPW: see [Function Diagrams](#) on page 21
- OMR and OMRW: see [Function Diagrams](#) on page 51
- OMH: see [Function Diagrams](#) on page 88

The function diagrams are based on actual tests on a representative number of motors from our production. The diagrams apply to a return pressure between 5 and 10 bar.

[75 and 150 psi] when using mineral based hydraulic oil with a viscosity of 35 mm²/s

[165 SUS] and a temperature of 50°C [120°F]. For further explanation concerning how to read and use the function diagrams, please consult the paragraph "Selection of motor size" in the technical information *General Orbital Motors 520L0232 Rev. B*.

Technical Information Orbital Motors Type OMP, OMR and OMH
Versions
Versions

Mounting flange	Spigot diameter (front /rear end)	Bolt circle diameter (BC)	Shaft	Port size	EU	US	Side port	End port	Flange port	Std. shaft seal	High pressure shaft seal	Drain connection	Check valve	Main type designation
2 hole oval flange (A2-flange)	Ø 82.5 mm [3.25 in]	Ø 106.4 mm [4.20 in]	Cyl. 25 mm	G ½	*		*				*	No	No	OMP
				G ½	*		*				*	Yes	No	OMP
				G ½	*			*			*	Yes	Yes	OMP
			Cyl. 1 inch	G ½	*		*				*	No	No	OMP
				G ½	*		*				*	Yes	No	OMP
				7/8 - 14 UNF		*	*				*	Yes	Yes	OMP
			Splined 1 inch	G ½	*		*				*	No	No	OMP
				G ½	*		*				*	Yes	No	OMP
4 hole oval flange (A4-flange)	Ø 82.5 mm [3.25 in]	Ø 106.4 mm [4.20 in]	Cyl. 32 mm	G ½	*		*			*		Yes	Yes	OMP
Square flange (C-flange)	Ø 44.4 mm [1.75 in]	Ø 82.5 mm [3.25 in]	Cyl. 25 mm Cyl. 1 inch	G ½	*			*		*		Yes	Yes	OMP
				7/8 - 14 UNF		*	*			*		Yes	Yes	OMP
				1/2 - 14 NPTF		*	*			*		Yes	Yes	OMP
Wheel	Ø 80 mm [3.15 in]	Ø 103 mm [4.06 in]	Cyl. 25 mm	G ½	*				*	*		Yes	Yes	OMPW
OMP motors with corrosion resistant parts														
2 hole oval flange (A2-flange)	Ø 82.5 mm [3.25 in]	Ø 106.4 mm [4.20 in]	Cyl. 25 mm	G ½	*		*			*		Yes	Yes	OMP C
OMP motors with needle bearings														
2 hole oval flange (A2-flange)	Ø 82.5 mm [3.25 in]	Ø 106.4 mm [4.20 in]	Cyl. 25 mm	G ½	*		*			*		Yes	Yes	OMP N
Wheel	Ø 80 mm [3.15 in]	Ø 103 [4.06]	Tap. 28.5 mm	G ½	*				*	*		Yes	Yes	OMPW N
OMP motors with free running gerotor														
2 hole oval flange (A2-flange)	Ø 82.5 mm [3.25 in]	Ø 106.4 mm [4.20 in]	Cyl. 25 mm	G ½	*		*			*		Yes	No	OMP

* Version is available.

Features available (options)

Low leakage (low speed valve)

Speed sensor

Viton shaft seal

Reverse rotation

Painted

Technical Information Orbital Motors Type OMP, OMR and OMH
Code Numbers
Code Numbers

Code numbers	Displacement [cm ³]													
	25	32	40	50	60	80	100	110	125	160	200	250	315	400
151-	0340	0341	0342	0310	0319	0311	0312	-	0313	0314	0315	0316	0317	0318
151-	0640	0641	0642	0610	-	0611	0612	0646	0613	0614	0615	0616	0617	0618
151-	-	-	-	5191	-	5192	5193	-	5194	5195	5196	5197	5198	5199
151-	-	-	-	0300	-	0301	0302	-	0303	0304	0305	0306	0307	0308
151-	-	-	-	0600	-	0601	0602	-	0603	0604	0605	0606	0607	0608
151-	7080	7081	7082	7041	-	7042	7043	-	7044*	7045	7046	7047	7048	7049
151-	-	-	-	0330	-	0331	0332	-	0333	0334	0335	0336	0337	0338
151-	-	-	-	0630	-	0631	0632	-	0633	0634	0635	0636	0637	0638
151-	-	5010	-	5001	-	5002	5003	-	5004	5005	5006	5007	5008	5009
151-	-	-	-	5211	-	5212	5213	-	5214	5215	5216	5217	5218	5219
151-	-	-	-	7061	-	7062	7063	-	5174	7065	7066	7067	7068	7069
151-	-	-	-	7021	-	7022	7023	-	7024	7025	7026	7027	7028	7029
151-	-	-	-	7101	-	7102	7103	-	7104	7105	7106	7107	7108	7109
OMP motors with corrosion resistant parts														
151-	-	-	-	1208	-	1209	1210	-	1217	1211	1212	1213	1214	1215
OMP motors with needle bearings														
151-	-	-	-	5311	-	5312	5313	-	-	5315	5316	-	5318	-
151-	-	-	-	5301	-	5302	5303	-	5304	5305	5306	5307	5308	5309
OMP motors with free running gerotor														
151-	-	-	-	-	-	-	0622	-	-	0624	0625	-	0627	-
	20	20	21	21	22	22	23	23	24	24	25	25	26	26

* Motor painted black

Ordering

Add the four digit prefix "151-" to the four digit numbers from the chart for complete code number.

Example:

151-0305 for an OMP 200 with A2 flange, cyl. 1 in shaft, port size G 1/2 and high pressure shaft seal.

Orders will not be accepted without the four digit prefix.

Technical Data
Technical data for OMP with 25 mm and 1 in cylindrical shaft

Type			OMP	OMP	OMP	OMP	OMP	OMP	OMP	
Motor size			25	32	40	50	60	80	100	
Geometric displacement	cm ³ [inch]		25.0 [1.53]	32.0 [1.96]	40.0 [2.45]	48.6 [2.97]	59.1 [3.61]	77.8 [4.76]	97.3 [5.95]	
	Max. speed	min ⁻¹	cont.	1600	1560	1500	1230	1000	770	615
[rpm]		int. ¹⁾	1800	1720	1750	1540	1250	960	770	
Max. torque	N·m [lbf·in]		cont.	33 [290]	43 [380]	52 [460]	93 [820]	115 [1020]	150 [1330]	190 [1680]
			int. ¹⁾	47 [420]	61 [540]	74 [660]	120 [1060]	140 [1240]	190 [1680]	230 [2040]
			peak ²⁾	67 [590]	86 [760]	107 [950]	140 [1240]	180 [1590]	220 [1950]	270 [2390]
Max. output	kW [hp]		cont.	4.5 [6.0]	5.8 [7.8]	7.0 [9.4]	10.0 [13.4]	10.0 [13.4]	10.0 [13.4]	11.0 [14.8]
			int. ¹⁾	6.1 [8.2]	7.8 [10.5]	10.6 [14.2]	12.0 [16.1]	12.0 [16.1]	12.0 [16.1]	13.0 [17.4]
Max. pressure drop	bar [psi]		cont.	100 [1450]	100 [1450]	100 [1450]	140 [2030]	140 [2030]	140 [2030]	140 [2030]
			int. ¹⁾	140 [2030]	140 [2030]	140 [2030]	175 [2540]	175 [2540]	175 [2540]	175 [2540]
			peak ²⁾	225 [3260]	225 [3260]	225 [3260]	225 [3260]	225 [3260]	225 [3260]	225 [3260]
Max. oil flow	l/min [US gal/min]		cont.	40 [10.6]	50 [13.2]	60 [15.9]	60 [15.9]	60 [15.9]	60 [15.9]	60 [15.9]
			int. ¹⁾	45 [11.9]	55 [14.5]	70 [18.5]	75 [19.8]	75 [19.8]	75 [19.8]	75 [19.8]
Max. starting pressure with bar unloaded shaft [psi]	standard		10 [145]	10 [145]	10 [145]	10 [145]	10 [145]	10 [145]	10 [145]	
	free running gerotor		-	-	-	-	-	-	2 [29]	
Min starting torque	at max. press drop cont.		30 [270]	40 [350]	45 [400]	80 [710]	100 [885]	135 [1200]	170 [1510]	
	at max. press.drop int. ¹⁾		40 [350]	55 [490]	63 [560]	100 [890]	120 [1060]	170 [1510]	210 [1860]	

¹⁾ Intermittent operation: the permissible values may occur for max. 10% of every minute.

²⁾ Peak load: the permissible values may occur for max. 1% of every minute.

Type			OMP	OMP	OMP	OMP	OMP	OMP	OMP
Motor size			110	125	160	200	250	315	400
Geometric displacement	cm ³ [inch]		112.5 [6.87]	125.0 [7.65]	155.7 [9.53]	194.6 [11.91]	242.3 [14.83]	306.1 [18.73]	389.2 [23.82]
	Max. speed	min ⁻¹	cont.	535	480	385	310	250	195
[rpm]		int. ¹⁾	670	600	480	385	310	245	190

Technical Information Orbital Motors Type OMP, OMR and OMH
Technical Data

Type			OMP	OMP	OMP	OMP	OMP	OMP	OMP
Motor size			110	125	160	200	250	315	400
Max. torque	N•m [lbf•in]	cont.	215 [1900]	240 [2120]	300 [2660]	300 [2660]	300 [2660]	300 [2660]	300 [2660]
		int. ¹⁾	260 [2300]	290 [2570]	370 [3280]	380 [3360]	410 [3630]	390 [3450]	420 [3720]
		peak ²⁾	320 [2830]	370 [3280]	430 [3810]	540 [4780]	550 [4870]	600 [5310]	600 [5310]
Max. output	kW [hp]	cont.	10 [13.4]	10 [13.4]	10 [13.4]	8.0 [10.7]	6.0 [8.1]	5.0 [6.7]	4.0 [5.4]
		int. ¹⁾	12.0 [16.1]	12.0 [16.1]	12.0 [16.1]	11.0 [14.8]	9.0 [12.1]	7.0 [9.4]	6.0 [8.1]
Max. pressure drop	bar [psi]	cont.	140 [2030]	140 [2030]	140 [2030]	115 [1670]	90 [1310]	75 [1090]	60 [870]
		int. ¹⁾	175 [2540]	175 [2540]	175 [2540]	150 [2180]	125 [1810]	100 [1450]	80 [1160]
		peak ²⁾	225 [3260]	225 [3260]	225 [3260]	225 [3260]	180 [2610]	160 [2320]	130 [1890]
Max. oil flow	l/min [US gal/min]	cont.	60 [15.9]	60 [15.9]	60 [15.9]	60 [15.9]	60 [15.9]	60 [15.9]	60 [15.9]
		int. ¹⁾	75 [19.8]	75 [19.8]	75 [19.8]	75 [19.8]	75 [19.8]	75 [19.8]	75 [19.8]
Max. starting pressure with bar unloaded shaft [psi]	standard		10 [145]	9 [130]	7 [100]	5 [75]	5 [75]	5 [75]	5 [75]
	free running gerotor		-	2 [29]	2 [29]	2 [29]	-	-	-
Min starting torque	at max. press drop cont. N•m [lbf•in]		190 [1680]	210 [1860]	280 [2480]	270 [2390]	280 [2480]	280 [2480]	280 [2480]
	at max. press.drop int. ¹⁾ N•m [lbf•in]		240 [2120]	270 [2390]	350 [3100]	360 [3190]	390 [3450]	370 [3280]	400 [3540]

¹⁾ Intermittent operation: the permissible values may occur for max. 10% of every minute.

²⁾ Peak load: the permissible values may occur for max. 1% of every minute.

Technical data for OMP with 1 in splined and 28.5 mm tapered shaft

Type			OMP	OMP	OMP	OMP	OMP	OMP	OMP	OMP	
Motor size			50	80	100	125	160	200	250	315	400
Geometric displacement	cm ³ [inch]		48.6 [2.97]	77.8 [4.76]	97.3 [5.95]	125.0 [7.65]	155.7 [9.53]	194.6 [11.91]	242.3 [14.83]	306.1 [18.73]	389.2 [23.82]
Max. speed	min ⁻¹	cont.	1230	770	615	480	385	310	250	195	155
	[rpm]	int. ¹⁾	1540	960	770	600	480	385	310	245	190
Max. torque	N•m [lbf•in]	cont.	93 [820]	150 [1330]	190 [1680]	240 [2120]	300 [2660]	360 [3190]	360 [3190]	360 [3190]	360 [3190]
		int. ¹⁾	120 [1060]	190 [1680]	230 [2040]	290 [2570]	370 [3280]	450 [3980]	460 [4070]	470 [4160]	460 [4070]
		peak ²⁾	140 [1240]	220 [1950]	270 [2390]	370 [3280]	430 [3810]	540 [4780]	550 [4870]	540 [4780]	560 [4960]

Technical Information Orbital Motors Type OMP, OMR and OMH
Technical Data

Type			OMP	OMP	OMP	OMP	OMP	OMP	OMP	OMP	OMP	
Motor size			50	80	100	125	160	200	250	315	400	
Max. output	kW [hp]	cont.	10.0 [13.4]	10.0 [13.4]	11.0 [14.8]	10.0 [13.4]	10.0 [13.4]	10.0 [13.4]	8.0 [10.7]	6.0 [8.0]	5.0 [6.7]	
		int. ¹⁾	12.0 [16.1]	12.0 [16.1]	13 [17.4]	12.0 [16.1]	12.0 [16.1]	12.0 [16.1]	12.0 [16.1]	10.5 [14.1]	7.5 [10.1]	6.0 [8.0]
Max. pressure drop	bar [psi]	cont.	140 [2030]	140 [2030]	140 [2030]	140 [2030]	140 [2030]	140 [2030]	140 [2030]	105 [1520]	90 [1310]	70 [1020]
		int. ¹⁾	175 [2540]	175 [2540]	175 [2540]	175 [2540]	175 [2540]	175 [2540]	175 [2540]	140 [2030]	120 [1740]	90 [1310]
		peak ²⁾	225 [3260]	225 [3260]	225 [3260]	225 [3260]	225 [3260]	225 [3260]	225 [3260]	180 [2610]	160 [2320]	130 [1890]
Max. oil flow	l/min [US gal/min]	cont.	60 [15.9]	60 [15.9]	60 [15.9]	60 [15.9]	60 [15.9]	60 [15.9]	60 [15.9]	60 [15.9]	60 [15.9]	60 [15.9]
		int. ¹⁾	75 [19.8]	75 [19.8]	75 [19.8]	75 [19.8]	75 [19.8]	75 [19.8]	75 [19.8]	75 [19.8]	75 [19.8]	75 [19.8]
Max. starting pressure with unloaded shaft	bar [psi]		10 [145]	10 [145]	10 [145]	9 [130]	7 [100]	5 [75]	5 [75]	5 [75]	5 [75]	
Min starting torque	at max. press drop cont. N•m [lbf•in]		80 [710]	135 [1200]	170 [1510]	210 [1860]	280 [2480]	340 [3010]	330 [2920]	340 [3010]	345 [3050]	
	at max. press.drop int. ¹⁾ N•m [lbf•in]		100 [890]	170 [1510]	210 [1860]	270 [2390]	350 [3100]	420 [3720]	440 [3890]	450 [3980]	425 [3760]	

¹⁾ Intermittent operation: the permissible values may occur for max. 10% of every minute.

²⁾ Peak load: the permissible values may occur for max. 1% of every minute.

Technical data for OMP with 32 mm cylindrical shaft

Type			OMP	OMP	OMP	OMP	OMP	OMP	OMP	OMP	OMP	
Motor size			50	80	100	125	160	200	250	315	400	
Geometric displacement	cm ³ [inch]		48.6 [2.97]	77.8 [4.76]	97.3 [5.95]	125.0 [7.65]	155.7 [9.53]	194.6 [11.91]	242.3 [14.83]	306.1 [18.73]	389.2 [23.82]	
Max. speed	min ⁻¹	cont.	1230	770	615	480	385	310	250	195	155	
	[rpm]	int. ¹⁾	1540	960	770	600	480	385	310	245	190	
Max. torque	N•m [lbf•in]	cont.	93 [820]	150 [1330]	190 [1680]	240 [2120]	300 [2660]	360 [3190]	460 [4070]	470 [4160]	490 [4340]	
		int. ¹⁾	120 [1060]	190 [1680]	230 [2040]	290 [2570]	370 [3280]	450 [3980]	570 [5050]	620 [5490]	630 [580]	
		peak ²⁾	140 [1240]	220 [1950]	270 [2390]	370 [3280]	430 [3810]	540 [4780]	670 [5930]	820 [7260]	840 [7440]	
Max. output	kW [hp]	cont.	10.0 [13.4]	10.0 [13.4]	11.0 [14.8]	10.0 [13.4]	10.0 [13.4]	10.0 [13.4]	9.5 [12.7]	7.5 [10.1]	6.5 [8.7]	
		int. ¹⁾	12.0 [16.1]	12.0 [16.1]	13.0 [17.4]	12.0 [16.1]	12.0 [16.1]	12.0 [16.1]	12.0 [16.1]	12.0 [16.1]	9.0 [12.1]	7.5 [10.1]
Max. pressure drop	bar [psi]	cont.	140 [2030]	140 [2030]	140 [2030]	140 [2030]	140 [2030]	140 [2030]	140 [2030]	140 [2030]	120 [1740]	95 [1380]
		int. ¹⁾	175 [2540]	175 [2540]	175 [2540]	175 [2540]	175 [2540]	175 [2540]	175 [2540]	175 [2540]	160 [2320]	125 [1810]
		peak ²⁾	225 [3260]	225 [3260]	225 [3260]	225 [3260]	225 [3260]	225 [3260]	225 [3260]	225 [3260]	225 [3260]	225 [3260]

Technical Information Orbital Motors Type OMP, OMR and OMH
Technical Data

Type			OMP	OMP	OMP	OMP	OMP	OMP	OMP	OMP	OMP
Motor size			50	80	100	125	160	200	250	315	400
Max. oil flow	l/min [US gal/min]	cont.	60 [15.9]	60 [15.9]	60 [15.9]	60 [15.9]	60 [15.9]	60 [15.9]	60 [15.9]	60 [15.9]	60 [15.9]
		int. ¹⁾	75 [19.8]	75 [19.8]	75 [19.8]	75 [19.8]	75 [19.8]	75 [19.8]	75 [19.8]	75 [19.8]	75 [19.8]
Max. starting pressure with unloaded shaft	bar [psi]		10 [145]	10 [145]	10 [145]	9 [130]	7 [100]	5 [75]	5 [75]	5 [75]	5 [75]
Min starting torque	at max. press drop cont. N•m [lbf•in]		80 [710]	135 [1200]	170 [1510]	210 [1860]	280 [2480]	340 [3010]	420 [3720]	460 [4070]	460 [4070]
	at max. press.drop int. ¹⁾ N•m [lbf•in]		100 [890]	170 [1510]	210 [1860]	270 [2390]	350 [3100]	420 [3720]	530 [4690]	600 [5310]	600 [5310]

¹⁾ Intermittent operation: the permissible values may occur for max. 10% of every minute.

²⁾ Peak load: the permissible values may occur for max. 1% of every minute.

Type		Max. inlet pressure	Max.return pressure with drain line
OMP 25 - 400	bar [psi] cont	175 [2540]	175 [2540]
	bar int. ¹⁾ [psi]	200 [2900]	200 [2900]
	bar peak ²⁾ [psi]	225 [3260]	225 [3260]

¹⁾ Intermittent operation: the permissible values may occur for max. 10% of every minute.

²⁾ Peak load: the permissible values may occur for max. 1% of every minute.

Technical Data - Max. Permissible Shaft Seal Pressure

OMP with HIGH Pressure Shaft Seal (HPS)

OMP with HPS and without drain connection:

The shaft seal pressure equals the average of input pressure and return pressure.

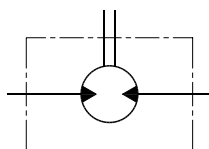

151-1743.10

$$P_{\text{seal}} = \frac{P_{\text{in}} + P_{\text{return}}}{2}$$

OMP with HPS and drain connection:

The shaft seal pressure equals the pressure in the drain line.

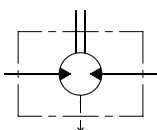

151-1855.10

Max. permissible shaft seal pressure

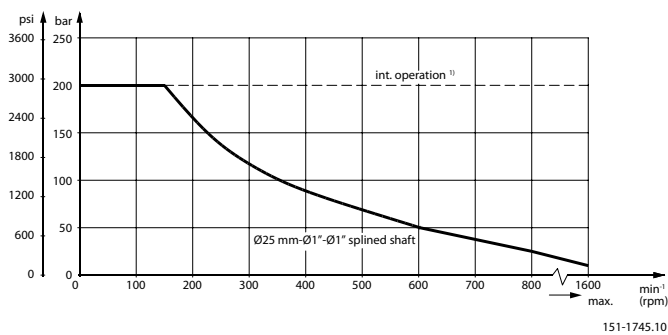

151-1745.10

OMP with Standard Shaft Seal

OMP with standard shaft seal, check valves and without use of drain connection:

The pressure on the shaft seal never exceeds the pressure in the return line

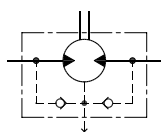

151-320.10

OMP with standard shaft seal, check valves and with drain connection:

The shaft seal pressure equals the pressure on the drain line.

Technical Data - Max. Permissible Shaft Seal Pressure

Max. return pressure without drain line or max. pressure in the drain line

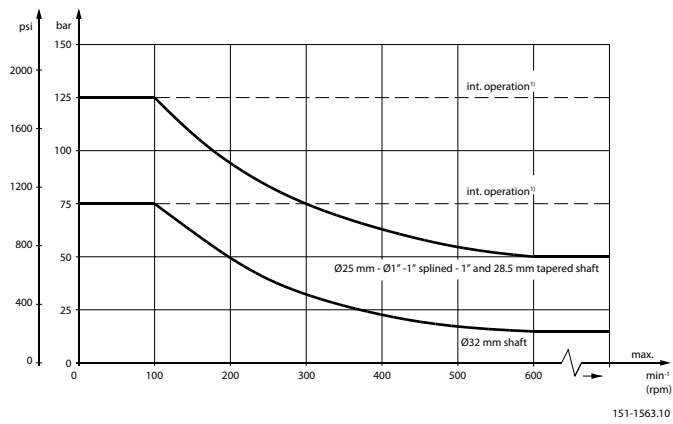

1) Intermittent operation: the permissible values may occur for max. 10% of every minute.

Technical Data
Pressure Drop in Motor

The curve applies to an unloaded motor shaft and an oil viscosity of 35 mm²/s [165 SUS]

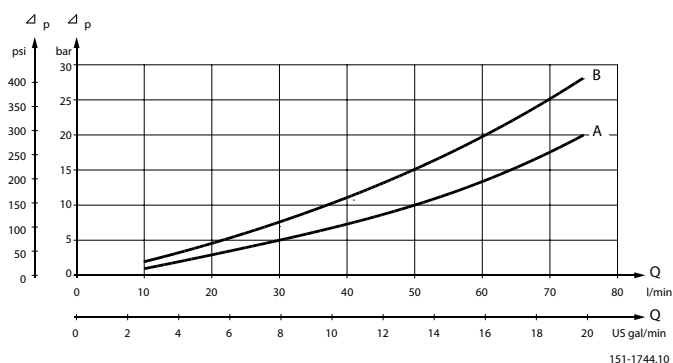

A: OMP 50 - 400

B: OMP 25 - 40 / OMPW

Oil flow in drain line

The table shows the max. oil flow in the drain line at a return pressure less than 5-10 bar [75-150 psi].

Pressure drop bar [psi]	Viscosity mm ² /s [SUS]	Oil flow in drain line l/min [US gal/min]
100 [1450]	20 [100]	2.5 [0.66]
	35 [165]	1.8 [0.78]
140 [2030]	20 [100]	3.5 [0.93]
	35 [165]	2.8 [0.74]

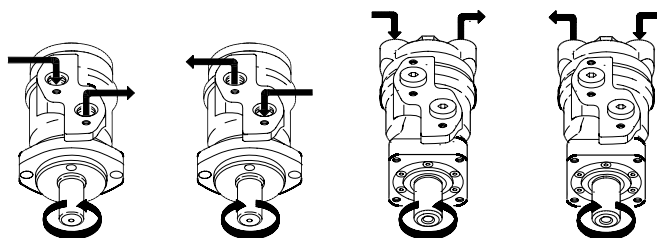
Direction of Shaft Rotation

151-1836.10

The permissible radial shaft load (PR) depends on

- Speed (n)
- Distance (L) from the point of load to the mounting flange
- Mounting flange version
- Shaft version

Mounting flange	4-oval flange** 2-hole oval flange (European version)	4-hole oval flange	Square flange** 2-hole oval flange (US-version)

Technical Information Orbital Motors Type OMP, OMR and OMH

Technical Data

Shaft version	25 mm cylindrical shaft 1 in cylindrical shaft 1 in splined shaft	32 mm cylindrical shaft	25 mm cylindrical shaft
Permissible shaft load (PR) - l in mm	800 250000 N* n 95 + L	800 187500 N* n 95 + L	800 250000 N* n 101 + L
Permissible shaft load (PR) - l in inch	800 2215 lbf* n 3.74 + L	800 1660 lbf* n 3.74 + L	800 2215 lbf* n 3.98 + L

* $n \geq 200 \text{ min}^{-1}$ [rpm]; $\leq 55 \text{ mm}$ [2.2 in]
 $n < 200 \text{ min}^{-1}$ [rpm]; $= > \text{PR}_{\text{max}} = 8000 \text{ N}$ [1800 lbf]
 ** For both European and US-version

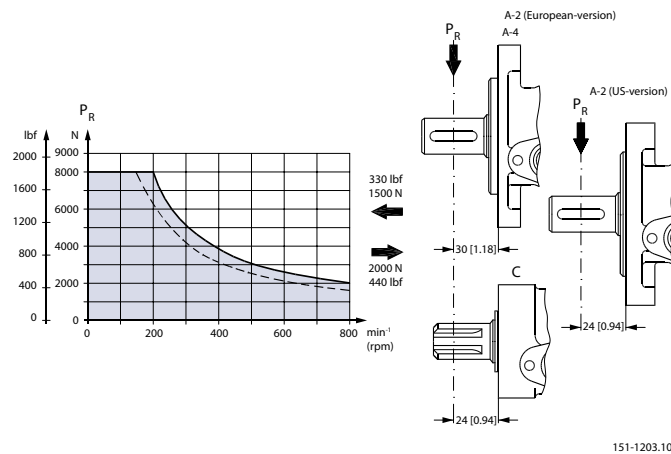

----- cylindrical shaft 32 mm [1.26 in]

_____ other shaft versions

The curve shows the relation between PR and n

- when $l = 30 \text{ mm}$ [1.18 in] for motors with A2 (European version) and A4 oval mounting flange
- when $l = 24 \text{ mm}$ [0.94 in] for motors with square mounting flange and A2 (US version)

For applications with special performance requirements we recommend OMP with the output shaft running in needle bearings.

Permissible Shaft Load for OMP N

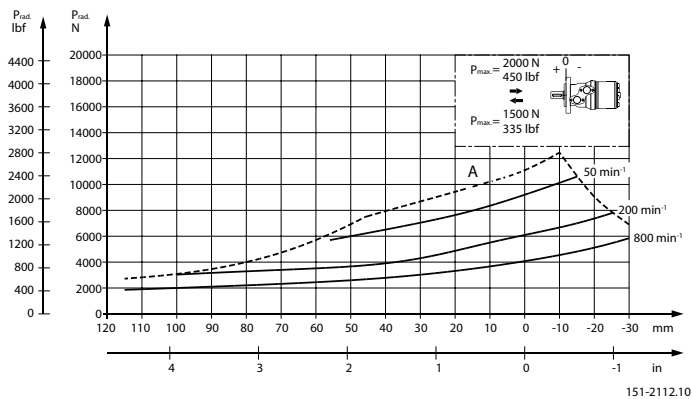

The output shaft on OMP N can be offered in needle bearings. These bearings and the recessed mounting flange allow a higher permissible radial load in comparison to OMP motors.

Technical Data

The permissible radial load on the shaft is shown for different speeds as a function of the distance from the mounting flange to the point of load application.

Curve A indicates the max. radial shaft load. Any shaft load exceeding the values quoted in curve A will involve risk of breakage.

The other curves apply to a B10 bearing life of 2000 hours at the number of revolutions indicated by the curve letter. Mineral based hydraulic oil with a sufficient content of anti-wear additives must be used.

Bearing life calculations can be made using the explanation and formula provided in the chapter "Bearing dimensioning" in the technical information "General Orbital Motors" 520L0232 Rev. B.

Permissible Shaft Load for OMPW with Slide Bearings

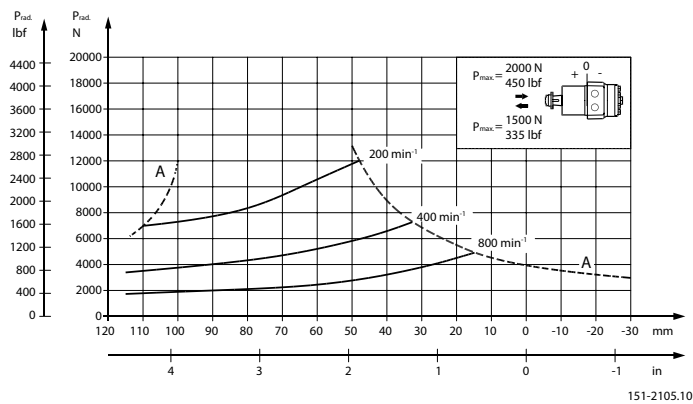

The output shaft on OMPW can be offered in slide bearings similar to the other OMP-motors. The permissible higher radial load is therefore due to the recessed mounting flange moving the point of load closer to the motor bearings.

The permissible radial load on the shaft is shown for different speeds as a function of the distance from the mounting flange to the point of load application.

The curves are not based on calculations of B10 bearing life. They represent absolute limits that must not be exceeded.

Curve A indicates the max. radial shaft load. Any shaft load exceeding the values quoted in curve A will involve risk of breakage.

Permissible Shaft Load for OMPW N with Needle Bearing

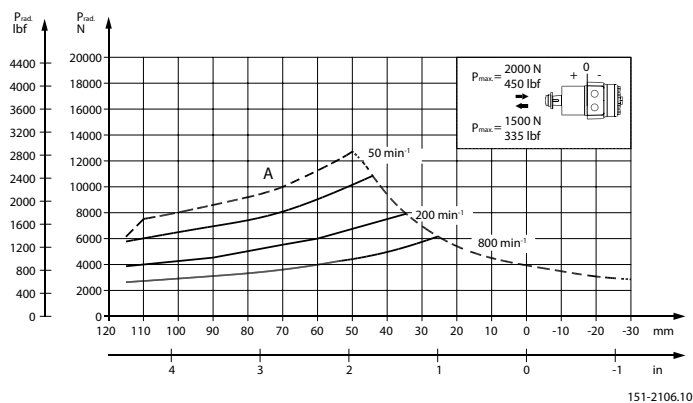

The output shaft on OMPW N can be offered in needle bearings. These bearings and the recessed mounting flange allow a higher permissible radial load in comparison to OMP motors.

Technical Data

The permissible radial load on the shaft is shown for different speeds as a function of the distance from the mounting flange to the point of load application.

Curve A indicates the max. radial shaft load. Any shaft load exceeding the values quoted in curve A will involve risk of breakage.

The other curves apply to a B10 bearing life of 2000 hours at the number of revolutions indicated by the curve letter. Mineral based hydraulic oil with a sufficient content of anti-wear additives must be used.

Bearing life calculations can be made using the explanation and formula provided in the chapter "Bearing dimensioning" in the technical information "General Orbital Motors" 520L0232 Rev. B.

Function Diagrams

Function Diagrams

Explanation of function diagram use, basis and conditions can be found in [Speed, Torque and Output](#) on page 8.

- Continuous range
- Intermittent range (max. 10% operation every minute)

Max. permissible continuous/intermittent pressure drop for the actual shaft version can be found in [Technical data for OMP with 25 mm and 1 in cylindrical shaft](#) on page 11.

Intermittent pressure drop and oil flow must not occur simultaneously.

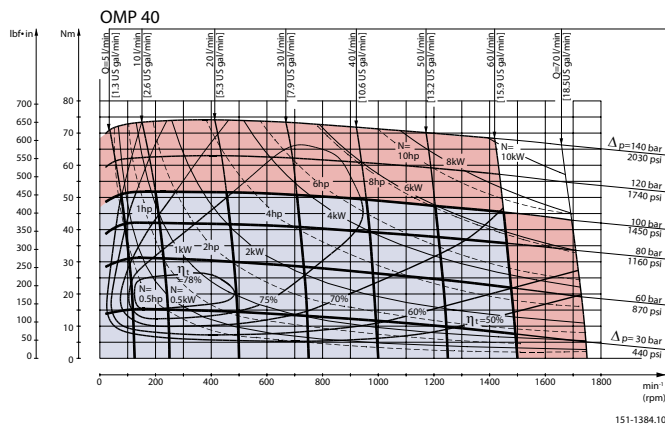
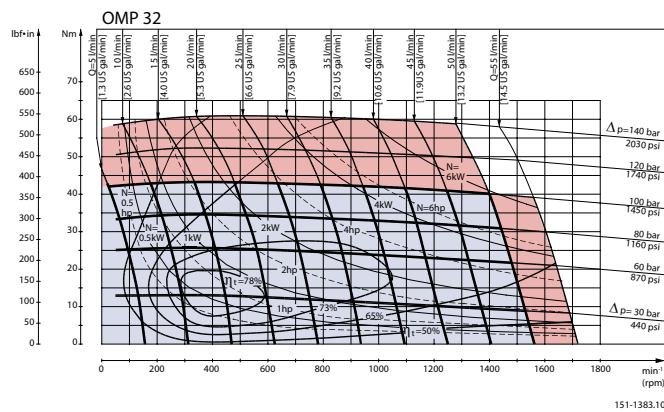
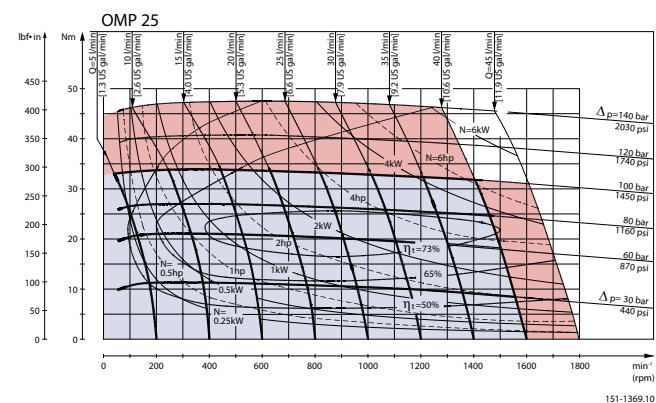

Function Diagrams

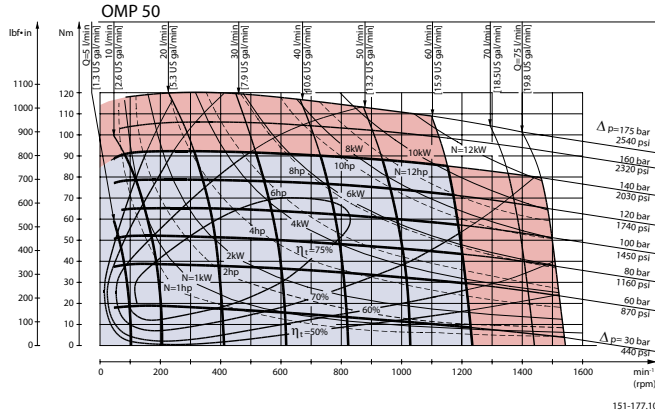

OMP 60 under preparation

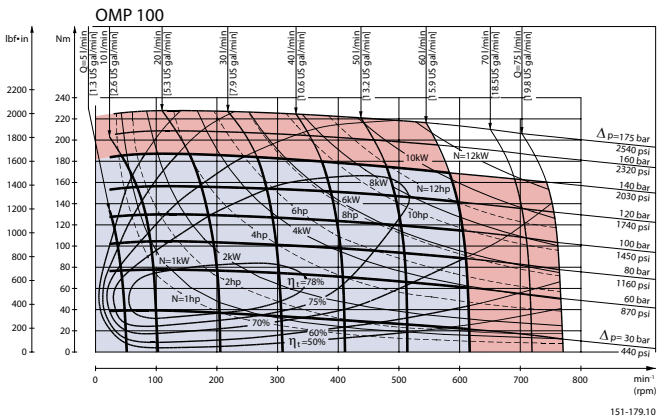
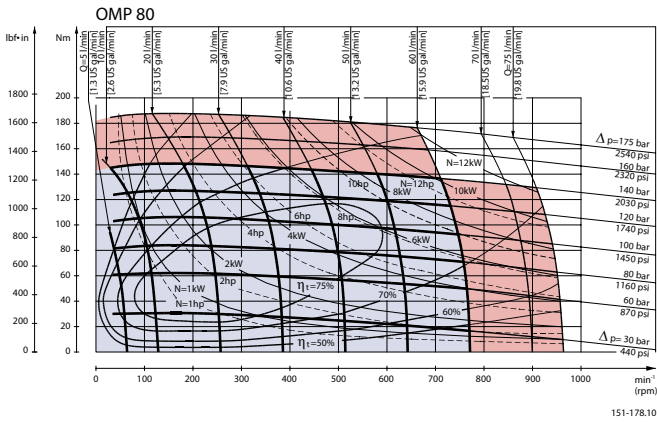

Function Diagrams

OMP 110 under preparation

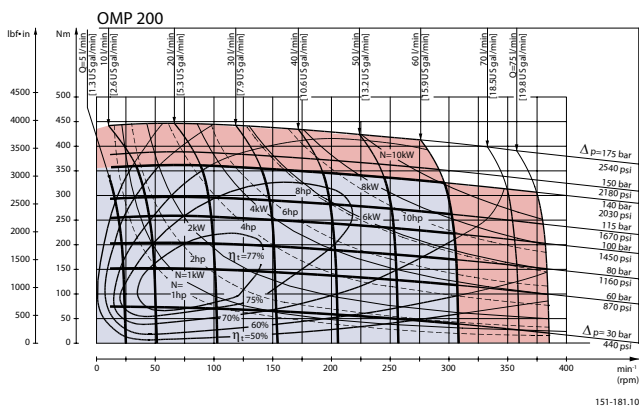
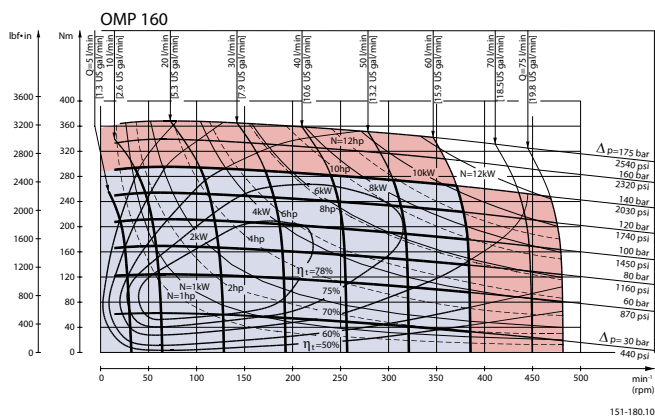
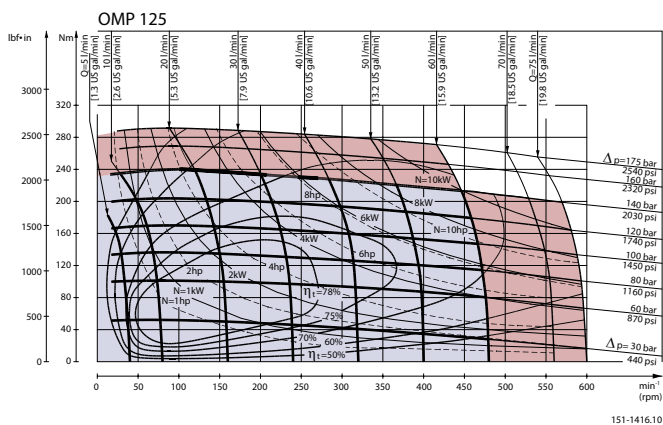

Function Diagrams

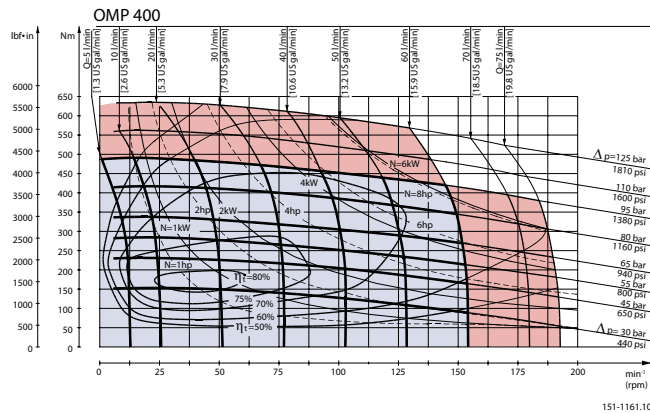
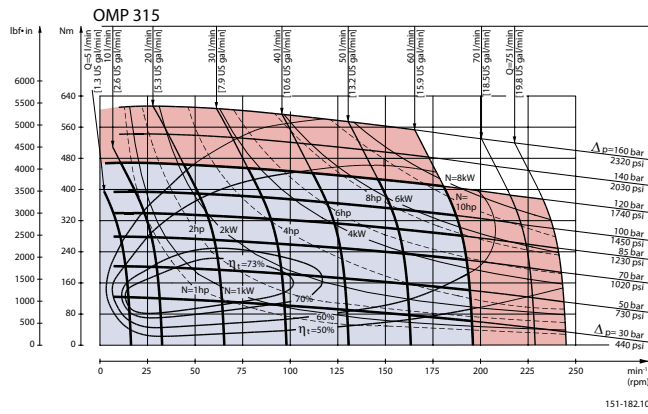
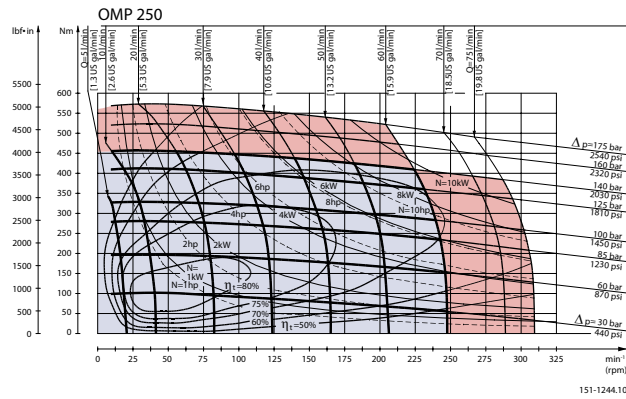

Shaft Version

Shaft Version

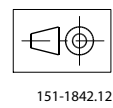
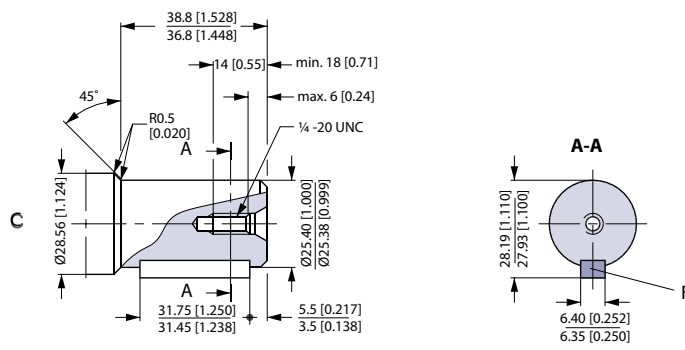
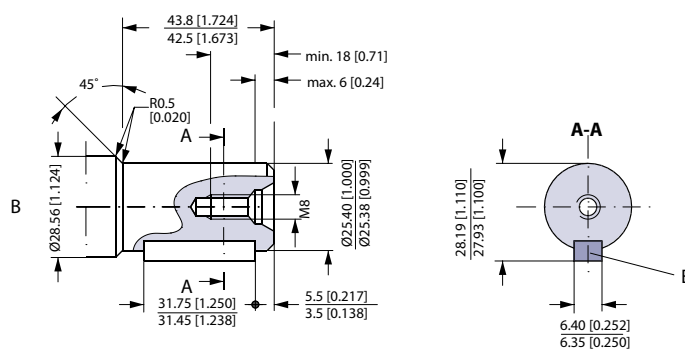
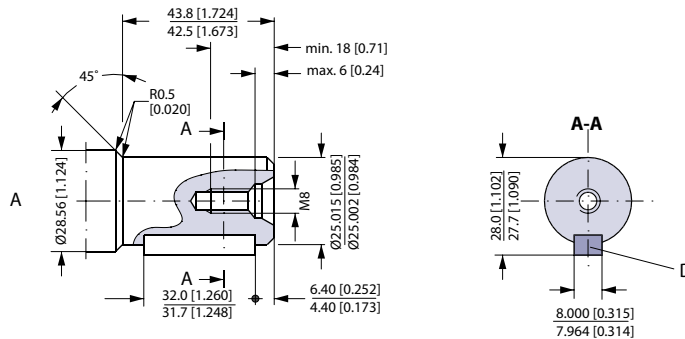

A: Cylindrical shaft
25 mm

B: Cylindrical shaft
1 in

US version
C: Cylindrical shaft
1 in

D: Parallel key
A8 • 7 • 32
DIN 6885

E: Parallel key
1/4 • 1/4 • 11/4 in
B.S. 46

F: Parallel key
1/4 • 1/4 • 11/4 in
B.S. 46

Shaft Version

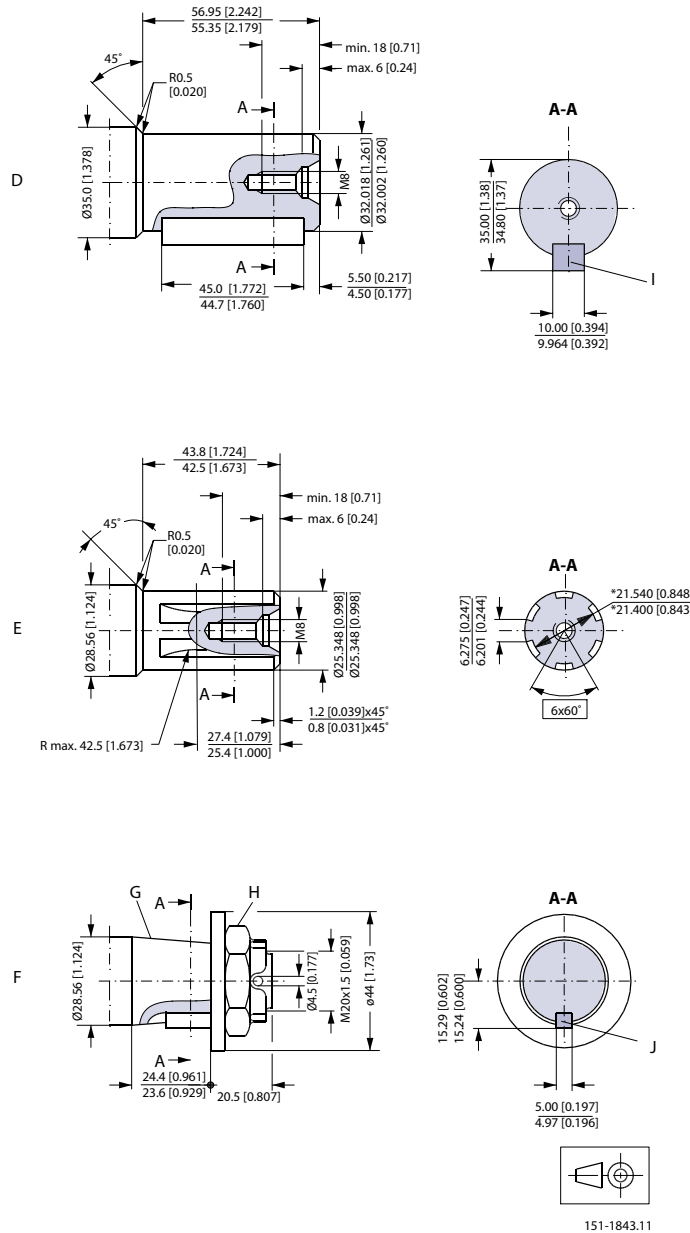

D: Cylindrical shaft 32 mm

G: Taper 1:10

F: Tapered shaft

E: Splined shaft

H: DIN 937

I: Parallel key

B.S. 2059 (SAE 6 B)

NV 30

A10 8 45

Straight-sided,
bottom fitting, dep.

Tightening torque:

DIN 6885

100 ± 10 N·m [885 ± 88.50 lbf·in]

Fit 2

Nom. size 1 in

* Deviates from BS 2059 (SAE 6B)

J: Parallel key

B5 5 14

DIN 6885

151-1843.11

Port Thread Versions

Port Thread Versions

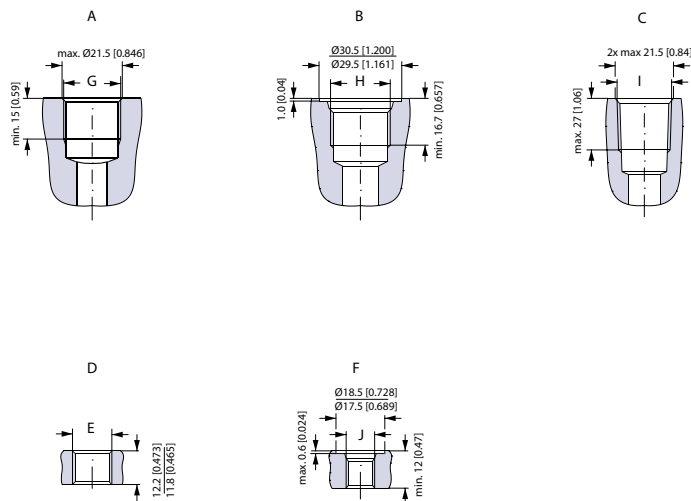

151-1844.11

- | | | |
|---------------------|--------------------------------------|--------------------|
| A: G main ports | B: UNF main ports | C: NPTF main ports |
| G: ISO 228/1 - G1/2 | H: 7/8 - 14 UNF
O-ring boss port | I: 1/2 - 14 NPTF |
| D: G drain port | F: UNF drain port | |
| E: ISO 228/1 - G1/4 | J: 7/16 - 20 UNF
O-ring boss port | |

Manifold Mount

European version

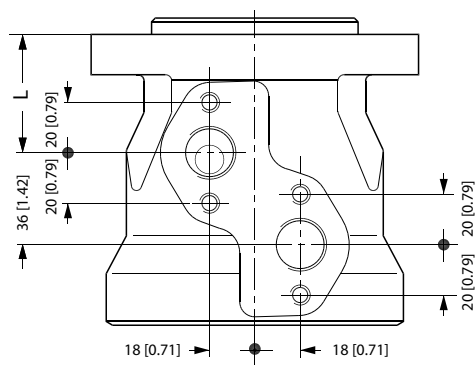

151-2135.10

L: see dimensional drawing for given OMP motor:

- [Dimensions - European Version](#) on page 28
- [Dimensions - US Version](#) on page 32
- [Dimensions - European Version](#) on page 33
- [Dimensions - US Version](#) on page 35
- [Dimensions - European Version](#) on page 37

Dimensions - European Version
Dimensions

Side port version with 2 hole oval mounting flange (A2-flange).

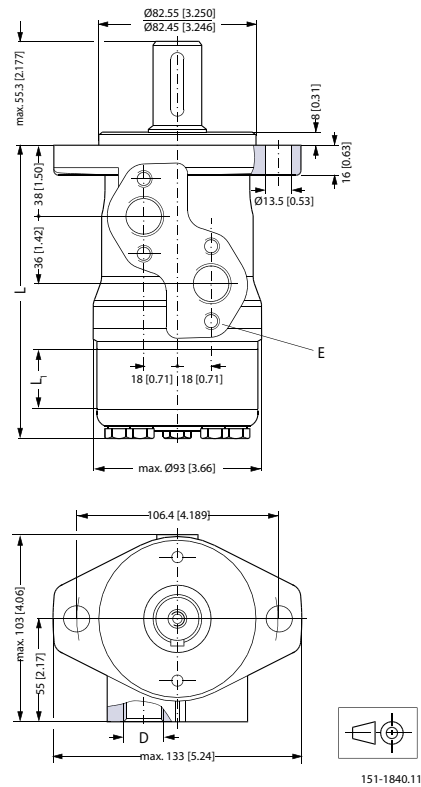

D: G 1/2; 15 mm [0.59 in] deep

E: M8; 13 mm [0.51 in] deep
(4 pcs.)

Type	Max. L mm [in]	L1 mm [in]
OMP 25	130.0 [5.12]	4.1 [0.16]
OMP 32	131.0[5.16]	5.2[0.20]
OMP 40	132.0 [5.20]	6.5 [0.26]
OMP 50	132.0 [5.20]	6.5 [0.26]
OMP 80	136.0 [5.35]	10.4 [0.41]
OMP 100	138.5 [5.45]	13.0 [0.51]
OMP 125	142.0 [5.59]	16.7 [0.66]
OMP 160	146.5 [5.77]	20.8 [0.82]
OMP 200	151.5 [5.96]	26.0 [1.02]
OMP 250	158.0[6.22]	32.5 [1.28]
OMP 315	166.5 [6.56]	40.9 [1.61]
OMP 400	177.6 [6.99]	52.0 [2.05]

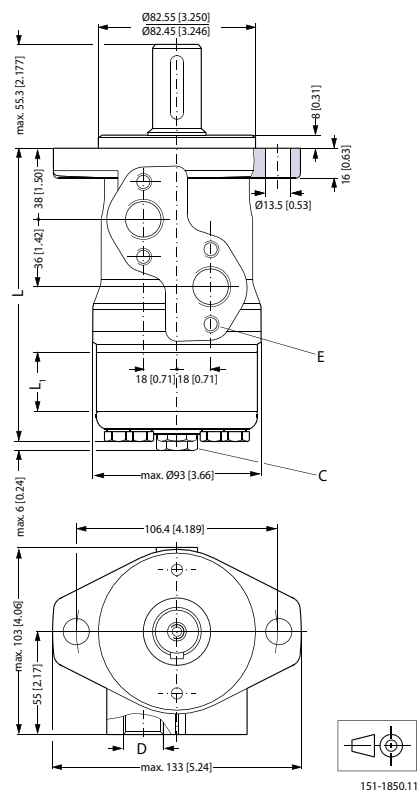
Dimensions - European Version
Side port version with 2 hole oval mounting flange (A2-flange). With drain connection.

C: Drain connection
 G ¼; 12 mm [0.47 in] deep

E: M8; 13 mm [0.51 in] deep
 (4 pcs.)

D: G ½; 15 mm [0.59 in] deep

Type	Max.L mm [in]	L1 mm [in]
OMP 25	130.0 [5.12]	4.1 [0.16]
OMP 32	131.0 [5.16]	5.2 [0.20]
OMP 40	132.0 [5.20]	6.5 [0.26]
OMP 50	132.0 [5.20]	6.5 [0.26]
OMP 80	136.0 [5.35]	10.4 [0.41]
OMP 100	138.5 [5.45]	13.0 [0.51]
OMP 125	142.0 [5.59]	16.7 [0.66]
OMP 160	146.5 [5.77]	20.8 [0.82]
OMP 200	151.5 [5.96]	26.0 [1.02]
OMP 250	158.0 [6.22]	32.5 [1.28]
OMP 315	166.5 [6.56]	40.9 [1.61]
OMP 400	177.6 [6.99]	52.0 [2.05]

Dimensions - European Version

OMP C and OMP N Side port version with 2 hole oval mounting flange (A2-flange).

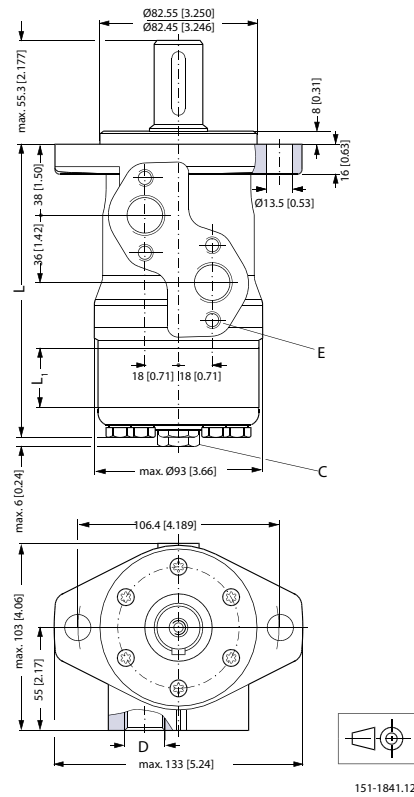

C: Drain connection
G ¼; 12 mm [0.47 in] deep

E: M8; 13 mm [0.51 in] deep
(4 pcs.)

D: G ½; 15 mm [0.59 in] deep

Type	Max. L mm [in]	L1 mm [in]
OMP 50	132.0 [5.20]	6.5 [0.26]
OMP 80	136.0 [5.35]	10.4 [0.41]
OMP 100	138.5 [5.45]	13.0 [0.51]
OMP 125	142.0 [5.59]	16.7 [0.66]
OMP 160	146.5 [5.77]	20.8 [0.82]
OMP 200	151.5 [5.97]	26.0 [1.02]
OMP 250	158.0 [6.22]	32.5 [1.28]
OMP 315	166.5 [6.56]	40.9 [1.61]
OMP 400	177.6 [6.99]	52.0 [2.05]

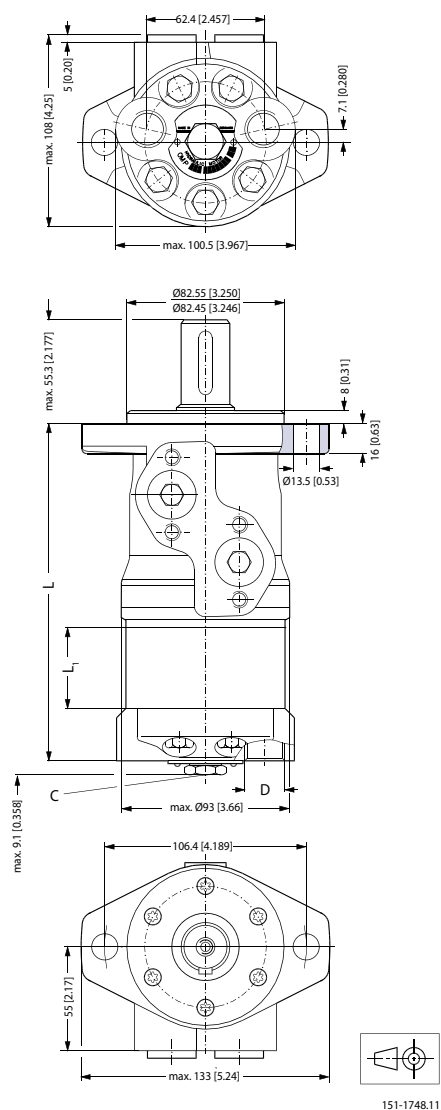
Dimensions - European Version
End port version with 2 hole oval mounting flange (A2-flange).

151-1748.11

C: Drain connection
 G ¼; 12 mm [0.47 in] deep

D: G ½; 15 mm [0.59 in] deep

Type	Max. L mm [in]	L1 mm [in]
OMP 50	146.1 [5.75]	6.5 [0.26]
OMP 80	150.0 [5.91]	10.4 [0.41]
OMP 100	152.7 [6.01]	13.0 [0.51]
OMP 125	156.2 [6.15]	16.7 [0.66]
OMP 160	160.4 [6.32]	20.8 [0.82]
OMP 200	165.6 [6.52]	26.0 [1.02]
OMP 250	172.1 [6.78]	32.5 [1.28]
OMP 315	180.5 [7.11]	40.9 [1.61]
OMP 400	191.6 [7.54]	52.0 [2.05]

Dimensions - US Version
Dimensions

Side port version with 2 hole oval mounting flange (A2-flange).

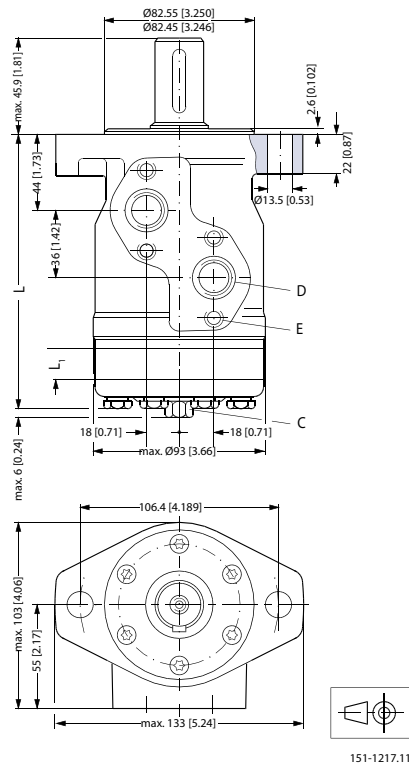

151-1217.11

C: Drain connection
G 7/16 UNF;
12 mm [0.47 in] deep

D: G 7/8 - 14 UNF;
16.7 mm [0.66 in] deep

E: M8; 13 mm [0.51 in] deep
(4 pcs.)

Type	Max. L mm [in]	L1 mm [in]
OMP 25	136.0 [5.35]	4.1 [0.16]
OMP 32	137.0 [5.39]	5.2 [0.20]
OMP 40	138.0 [5.43]	6.5 [0.26]
OMP 50	138.0 [5.43]	6.5 [0.26]
OMP 80	142.0 [5.59]	10.4 [0.41]
OMP 100	144.5 [5.69]	13.0 [0.51]
OMP 125	148.0 [5.83]	16.7 [0.66]
OMP 160	152.5 [6.00]	20.8 [0.82]
OMP 200	157.5 [6.20]	26.0 [1.02]
OMP 250	164.0 [6.46]	32.5 [1.28]
OMP 315	172.5 [6.79]	40.9 [1.61]
OMP 400	183.6 [7.23]	52.0 [2.05]

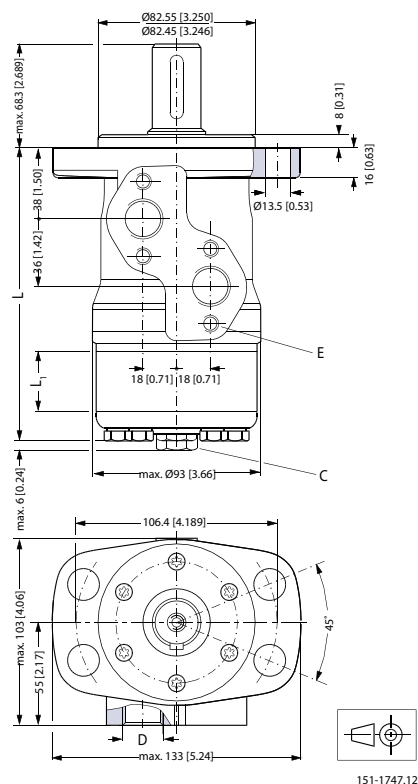
Dimensions - European Version
Dimensions
Side port version with 4 hole oval mounting flange (A4-flange).

C: Drain connection

G ¼; 12 mm [0.47 in] deep

E: M8; 13 mm [0.51 in] deep

(4 pcs.)

D: G ½; 15 mm [0.59 in] deep

Type	Max. L mm [in]	L1 mm [in]
OMP 50	132.0 [5.20]	6.5 [0.26]
OMP 80	136.0 [5.35]	10.4 [0.41]
OMP 100	138.5 [5.45]	13.0 [0.51]
OMP 125	142.0 [5.59]	16.7 [0.66]
OMP 160	146.5 [5.77]	20.8 [0.82]
OMP 200	151.5 [5.97]	26.0 [1.02]
OMP 250	158.0 [6.22]	32.5 [1.28]
OMP 315	166.5 [6.56]	40.9 [1.61]
OMP 400	177.6 [6.99]	52.0 [2.05]

Dimensions - European Version

End port version with square mounting flange (C-flange).

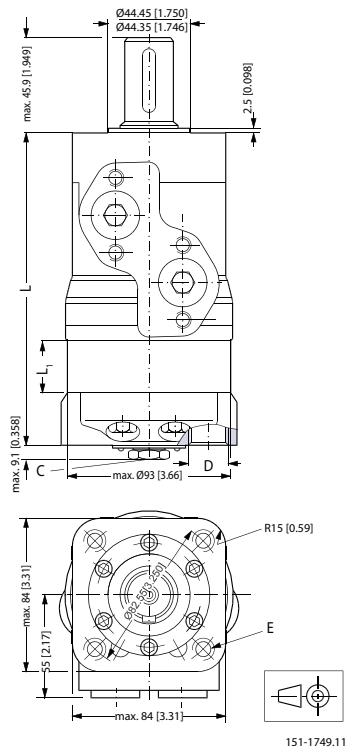

C: Drain connection
G ¼; 12 mm [0.47 in] deep
(4 pcs.)

D: G ½; 15 mm [0.59 in] deep

E: M10; 15 mm [0.59 in] deep

Type	Max. L mm [in]	L1mm [in]
OMP 50	152.0 [5.98]	6.5 [0.26]
OMP 80	156.0 [6.14]	10.4 [0.41]
OMP 100	158.6 [6.24]	13.0 [0.51]
OMP 125	162.1 [6.38]	16.7 [0.66]
OMP 160	166.4 [6.55]	20.8 [0.82]
OMP 200	171.6 [6.76]	26.0 [1.02]
OMP 250	178.1 [7.01]	32.5 [1.28]
OMP 315	186.5 [7.34]	40.9 [1.61]
OMP 400	197.6 [7.78]	52.0 [2.05]

Dimensions - US Version

Dimensions

Side port version with square mounting flange (C-flange).

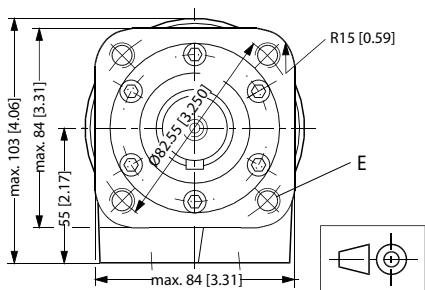
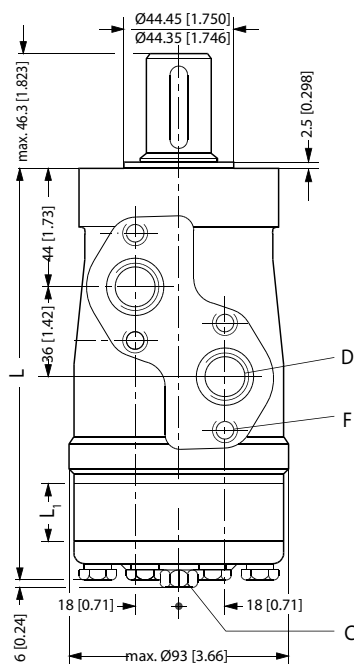

151-1214.11

C: Drain connection
7/16 - 20 UNF;
12 mm [0.47 in] deep

E: 3/8 - 16 UNC;
15 mm [0.59 in] deep
(4 off)

D: 7/8 - 14 UNF;
16.76 mm [0.66 in] deep
or 1/2 - 14 NPTF

F: M8; 13 mm [0.51 in] deep
(4 pcs.)

Type	Max. L mm [in]	L1 mm [in]
OMP 50	132.0 [5.20]	6.5 [0.26]
OMP 80	136.0 [5.35]	10.4 [0.41]
OMP 100	138.5 [5.45]	13.0 [0.51]
OMP 125	142.0 [5.59]	16.7 [0.66]

Dimensions - US Version

Type	Max. L mm [in]	L1 mm [in]
OMP 160	146.5 [5.77]	20.8 [0.82]
OMP 200	151.5 [5.97]	26.0 [1.02]
OMP 250	158.0 [6.22]	32.5 [1.28]
OMP 315	166.5 [6.56]	40.9 [1.61]
OMP 400	177.6 [6.99]	52.0 [2.05]

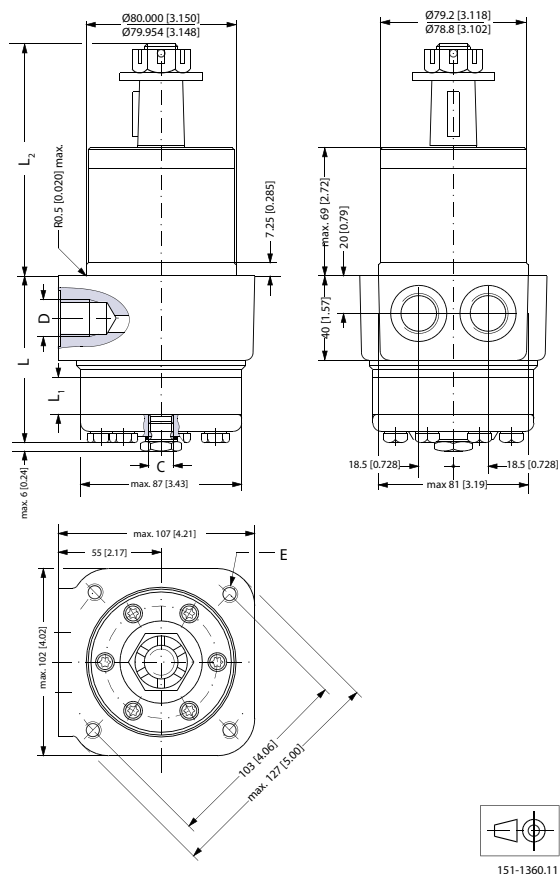
Dimensions - European Version
Dimensions
OMPW and OMPW N wheel motor

C: Drain connection

G $\frac{1}{4}$; 12 mm [0.47 in] deep

E: M10; 20 mm [0.79 in] deep
(4 pcs.)

D: G $\frac{1}{2}$; 15 mm [0.59 in] deep

Output shaft.max.	L2 mm [in]
Cylindrical shaft 25 mm [0.98 in]	max. 115 [4.53]
Tapered shaft 28.56 mm [1.12 in]	max. 117.8 [4.64]

Type	Max. L mm [in]	L1 mm [in]
OMP 50	71.8 [2.83]	6.5 [0.26]
OMP 80.	75.7 [2.98]	10.4 [0.41]
OMP 100	78.3 [3.08]	13.0 [0.51]
OMP 125	81.6 [3.21]	16.7 [0.66]
OMP 160	86.1 [3.39]	20.8 [0.82]
OMP 200	91.3 [3.60]	26.0 [1.02]

Dimensions - European Version

Type	Max. L mm [in]	L1 mm [in]
OMP 250	97.8 [3.85]	32.5 [1.28]
OMP 315	106.2 [4.18]	40.9 [1.61]
OMP 400	117.3 [4.62]	52.0 [2.05]

Technical Information Orbital Motors Type OMP, OMR and OMH
Versions
Versions

Mounting flange	Spigot diameter (front/rear end)	Bolt circle diameter (BC)	Shaft	Port size	EU	US	Side port	End port	Flange port	Std. shaft seal	High pressure shaft seal	Drain connection	Check valve	Main type designation		
2 hole oval flange (A2-flange)	Ø 82.5 mm [3.25 in]	Ø 106.4 mm [4.20 in]	Cyl. 25 mm	G ½	*		*				*	No	No	OMR		
				G ½	*		*				*	Yes	Yes	OMR		
				G ½	*			*			*	Yes	Yes	OMR		
			Cyl. 1 inch				G ½	*		*			*	No	No	OMR
							G ½	*		*			*	Yes	Yes	OMR
							7/8 - 14 UNF		*	*			*	Yes	Yes	OMR
			Splined 1 inch				G ½	*		*			*	No	No	OMR
							G ½	*		*			*	Yes	Yes	OMR
							7/8 - 14 UNF		*	*			*	Yes	Yes	OMR
			Cyl. 32 mm				G ½	*		*			*	Yes	Yes	OMR
Tap. 28.5 mm	G ½	*						*			*	Yes	Yes	OMR		
4 hole oval flange (A4-flange)	Ø 82.5 mm [3.25 in]	Ø 106.4 mm [4.20 in]	Cyl. 25 mm	G ½	*		*			*		Yes	Yes	OMR		
				Cyl. 32 mm	G ½	*		*			*		Yes	Yes	OMR	
				Cyl. 1¼ in	7/8 - 14 UNF		*	*			*		Yes	Yes	OMR	
Square flange (C-flange)	Ø 44.4 mm [1.75 in]	Ø 82.5 mm [3.25 in]	Cyl. 25 mm	G ½	*			*		*		Yes	Yes	OMR		
				Cyl. 1 in	7/8 - 14 UNF		*	*			*		Yes	Yes	OMR	
OMR motors with corrosion resistant parts																
2 hole oval flange (A2-flange)	Ø 82.5 mm [3.25 in]	Ø 106.4 mm [4.20 in]	Cyl. 25 mm	G ½	*		*			*		Yes	Yes	OMR C		
OMR motors with needle bearings																
2 hole oval flange (A2-flange)	Ø 82.5 mm [3.25 in]	Ø 106.4 mm [4.20 in]	Cyl. 25 mm	G ½	*		*			*		Yes	Yes	OMR N		
Wheel	Ø 82.5 mm [3.25 in]	Ø 147.6 mm [5.81 in]	Tap. 35 mm	G ½	*				*	*		Yes	Yes	OMRW N		
				Tap. 1¼ in	7/8 - 14 UNF		*	*		*	*		Yes	Yes	OMRW N	
OMR motors with integrated brake																
2 hole oval flange (A2-flange)	Ø 82.5 mm [3.25 in]	Ø 106.4 mm [4.20 in]	Cyl. 25 mm	G ½	*		*			*		Yes	Yes	OMR F		
OMR motors with integrated brake and needle bearings																
2 hole oval flange (A2-flange)	Ø 82.5 mm [3.25 in]	Ø 106.4 mm [4.20 in]	Cyl. 1 in	7/8 - 14 UNF		*	*			*		Yes	Yes	OMR NF		
Wheel	Ø 82.5 mm [3.25 in]	Ø 147.6 mm [5.81 in]	Tap. 35 mm	G ½	*				*	*		Yes	Yes	OMRW NF		

* Version is available.

Versions

Features available (options)

Low leakage (low speed valve) Reverse rotation

Speed sensor Painted

Viton shaft seal

Technical Information Orbital Motors Type OMP, OMR and OMH

Code Numbers

Code Numbers

Code numbers	Displacement [cm ³]								
	50	80	100	125	160	200	250	315	375
151-	0410	0411	0412	0413	0414	0415	0416	0417	0418
151-	0710	0711	0712	0713	0714	0715	0716	0717	0718
151-	6190	6191	6192	6193	6194	6195	6196	6197	6198
151-	0400	0401	0402	0403	0404	0405	0406	0407	0408
151-	0700	0701	0702	0703	0704	0705	0706	0707	0708
151-	7240	7241	7242	7243	7244	7245	7246	7247	7248
151-	0420	0421	0422	0423	0424	0425	0426	0427	0428
151-	0720	0721	0722	0723	0724	0725	0726	0727	0728
151-	7250	7251	7252	7253	7254	7255	7256	7257	7258
151-	0248	0242	0243	0208	0244	0245	0247	0246	6294
151-	0265	0266	0267	6295	0268	0269	0271	0270	6296
151-	6010	6011	6012	6013	6014	6015	6016	6017	6018
151-	6000	6001	6002	6003	6004	6005	6006	6007	6008
151-	6110	6111	6112	6113	6114	6115	6116	6117	6118
151-	6210	6211	6212	6213	6214	6215	6216	6217	6218
151-	7260	7261	7262	7263	7264	7265	7266	7267	7269
OMR motors with corrosion resistant parts									
151-	1231	1232	1233	1238	1234	1235	1236	1237	1243
OMR motors with needle bearings									
151-	6380	6381	-	6383	6384	6385	6386	6387	6388
151-	6300	6301	6302	6303	6304	6305	6306	6307	6308
151-	6430	6431	6432	6433	6434	6435	6436	6437	6438
OMR motors with integrated brake									
151-	-	6461	6462	6463	6464	6465	6466	6467	6468
OMR motors with integrated brake and needle bearings									
151-	-	6471	6472	6473	6474	6475	6476	6477	6478
151-	-	-	6442	6443	6444	6445	-	-	-
	51	51	52	52	53	53	54	54	55

Ordering

Add the four digit prefix "151-" to the four digit numbers from the chart for complete code number.

Example:

151-6004 for an OMR 160 with A4 flange, cyl. 32 mm shaft, port size G 1/2 and side port version.

Orders will not be accepted without the four digit prefix.

Technical Data
Technical data for OMR with 25 mm and 1 in cylindrical shaft

Type			OMR	OMR	OMR	OMR	OMR	OMR	OMR	OMR	OMR
Motor size			50	80	100	125	160	200	250	315	375
Geometric displacement	cm ³ [inch]		51.6 [3.16]	80.3 [4.91]	99.8 [6.11]	125.7 [7.69]	159.6 [9.77]	199.8 [12.23]	249.3 [15.26]	315.7 [19.32]	372.6 [22.80]
Max. speed	min ⁻¹	cont.	775	750	600	475	375	300	240	190	160
	[rpm]	int. ¹⁾	970	940	750	600	470	375	300	240	200
Max. torque	N•m [lbf•in]	cont.	100 [890]	195 [1730]	240 [2120]	300 [2660]	300 [2660]	300 [2660]	300 [2660]	300 [2660]	300 [2660]
		int. ¹⁾	130 [1150]	220 [1960]	280 [2480]	340 [3010]	390 [3450]	390 [3450]	380 [3360]	420 [3720]	430 [3810]
		peak ²⁾	170 [1510]	270 [2390]	320 [2830]	370 [3280]	460 [4070]	560 [4960]	600 [5310]	610 [5400]	600 [5310]
Max. output	kW [hp]	cont.	7.0 [9.4]	12.5 [16.8]	13.0 [17.4]	12.5 [16.8]	10.0 [13.4]	8.0 [10.7]	6.0 [8.1]	5.0 [6.7]	4.0 [5.4]
		int. ¹⁾	8.5 [11.4]	15.0 [20.1]	15.0 [20.1]	14.5 [19.4]	12.5 [16.8]	10.0 [13.4]	8.0 [10.7]	6.5 [8.7]	6.0 [8.1]
Max. pressure drop	bar [psi]	cont.	140 [2030]	175 [2540]	175 [2540]	175 [2540]	130 [1890]	110 [1600]	80 [1160]	70 [1020]	55 [800]
		int. ¹⁾	175 [2540]	200 [2900]	200 [2900]	200 [2900]	175 [2540]	140 [2030]	110 [1600]	100 [1450]	85 [1230]
		peak ²⁾	225 [3260]	225 [3260]	225 [3260]	225 [3260]	225 [3260]	225 [3260]	200 [2900]	150 [2180]	130 [1890]
Max. oil flow	l/min [US gal/min]	cont.	40 [10.6]	60 [15.9]	60 [15.9]	60 [15.9]	60 [15.9]	60 [15.9]	60 [15.9]	60 [15.9]	60 [15.9]
		int. ¹⁾	50 [13.2]	75 [19.8]	75 [19.8]	75 [19.8]	75 [19.8]	75 [19.8]	75 [19.8]	75 [19.8]	75 [19.8]
Max. starting pressure with unloaded shaft	bar [psi]		10 [145]	10 [145]	10 [145]	9 [130]	7 [100]	5 [75]	5 [75]	5 [75]	5 [75]
Min starting torque	at max. press drop cont. N•m [lbf•in]		80 [710]	150 [1330]	200 [1770]	250 [2210]	240 [2120]	260 [2300]	240 [2120]	260 [2300]	240 [2120]
	at max. press.drop int. ¹⁾ N•m [lbf•in]		100 [890]	170 [1510]	230 [2040]	280 [2480]	320 [2830]	330 [2920]	310 [2740]	350 [3100]	380 [3360]

¹⁾ Intermittent operation: the permissible values may occur for max. 10% of every minute.

²⁾ Peak load: the permissible values may occur for max. 1% of every minute.

Technical data for OMR with 1 in splined and 28.5 mm tapered shaft

Type			OMR	OMR	OMR	OMR	OMR	OMR	OMR	OMR	OMR
Motor size			50	80	100	125	160	200	250	315	375
Geometric displacement	cm ³ [inch]		51.6 [3.16]	80.3 [4.91]	99.8 [6.11]	125.7 [7.69]	159.6 [9.77]	199.8 [12.23]	249.3 [15.26]	315.7 [19.32]	372.6 [22.80]
Max. speed	min ⁻¹	cont.	775	750	600	475	375	300	240	190	160
	[rpm]	int. ¹⁾	970	940	750	600	470	375	300	240	200

Technical Information Orbital Motors Type OMP, OMR and OMH
Technical Data

Type			OMR	OMR	OMR	OMR	OMR	OMR	OMR	OMR	OMR
Motor size			50	80	100	125	160	200	250	315	375
Max. torque	N·m [lbf·in]	cont.	100 [890]	195 [1730]	240 [2120]	300 [2660]	360 [3190]	360 [3190]	360 [3190]	360 [3190]	360 [3190]
		int. ¹⁾	130 [1150]	220 [1950]	280 [2480]	340 [3010]	430 [3810]	440 [3890]	470 [4160]	470 [4160]	460 [4070]
		peak ²⁾	170 [1510]	270 [2390]	320 [2830]	370 [3280]	460 [4070]	560 [4960]	600 [5310]	610 [5400]	600 [5310]
Max. output	kW [hp]	cont.	7.0 [9.4]	12.5 [16.8]	13.0 [17.4]	12.5 [16.8]	12.5 [16.8]	10.0 [13.4]	7.0 [9.4]	5.0 [6.7]	5.0 [6.7]
		int. ¹⁾	8.5 [11.4]	15.0 [20.1]	15.0 [20.1]	14.5 [19.4]	14.0 [18.8]	13.0 [17.4]	9.5 [12.7]	8.0 [10.7]	7.0 [9.4]
Max. pressure drop	bar [psi]	cont.	140 [2030]	175 [2540]	175 [2540]	175 [2540]	165 [2390]	130 [1890]	100 [1450]	85 [1230]	70 [1020]
		int. ¹⁾	175 [2540]	200 [2900]	200 [2900]	200 [2900]	200 [2900]	175 [2540]	140 [2030]	115 [1670]	90 [1310]
		peak ²⁾	225 [3260]	225 [3260]	225 [3260]	225 [3260]	225 [3260]	225 [3260]	200 [2900]	150 [2180]	130 [1890]
Max. oil flow	l/min [US gal/min]	cont.	40 [10.6]	60 [15.9]	60 [15.9]	60 [15.9]	60 [15.9]	60 [15.9]	60 [15.9]	60 [15.9]	60 [15.9]
		int. ¹⁾	50 [13.2]	75 [19.8]	75 [19.8]	75 [19.8]	75 [19.8]	75 [19.8]	75 [19.8]	75 [19.8]	75 [19.8]
Max. starting pressure with unloaded shaft	bar [psi]		10 [145]	10 [145]	10 [145]	9 [130]	7 [100]	5 [75]	5 [75]	5 [75]	5 [75]
Min starting torque	at max. press drop cont. N·m [lbf·in]		80 [710]	150 [1330]	200 [1770]	250 [2210]	300 [2660]	300 [2660]	290 [2570]	315 [2790]	300 [2660]
	at max. press.drop int. ¹⁾ N·m [lbf·in]		100 [890]	170 [1510]	230 [2040]	280 [2480]	350 [3100]	400 [3540]	400 [3540]	400 [3540]	380 [3360]

¹⁾ Intermittent operation: the permissible values may occur for max. 10% of every minute.

²⁾ Peak load: the permissible values may occur for max. 1% of every minute.

Technical data for OMR with 32 mm, 1 ¼ in cylindrical shaft and 35 mm, 1 ¼ in tapered shaft

Type			OMR	OMR	OMR	OMR	OMR	OMR	OMR	OMR	OMR
Motor size			50	80	100	125	160	200	250	315	375
Geometric displacement	cm ³ [inch]		51.6 [3.16]	80.3 [4.91]	99.8 [6.11]	125.7 [7.69]	159.6 [9.77]	199.8 [12.23]	249.3 [15.26]	315.7 [19.32]	372.6 [22.80]
Max. speed	min ⁻¹	cont.	775	750	600	475	375	300	240	190	160
	[rpm]	int. ¹⁾	970	940	750	600	470	375	300	240	200
Max. torque	N·m [lbf·in]	cont.	100 [890]	195 [1730]	240 [2120]	300 [2660]	380 [3360]	450 [3980]	540 [4780]	550 [4870]	580 [5130]
		int. ¹⁾	130 [1150]	220 [1957]	280 [2480]	340 [3010]	430 [3810]	500 [4430]	610 [5400]	690 [6110]	690 [6110]
		peak ²⁾	170 [1510]	270 [2390]	320 [2830]	370 [3280]	460 [4070]	560 [4960]	710 [6280]	840 [7440]	830 [7350]
Max. output	kW [hp]	cont.	7.0 [9.4]	12.5 [16.8]	13.0 [17.4]	12.5 [16.8]	12.5 [16.8]	11.0 [14.8]	10.0 [13.4]	9.0 [12.1]	7.5 [10.1]
		int. ¹⁾	8.5 [11.4]	15.0 [20.1]	15.0 [20.1]	14.5 [19.4]	14.0 [18.8]	13.0 [17.4]	12.0 [16.1]	10.0 [13.4]	9.0 [12.1]

Technical Information Orbital Motors Type OMP, OMR and OMH

Technical Data

Type			OMR	OMR	OMR	OMR	OMR	OMR	OMR	OMR	OMR	
Motor size			50	80	100	125	160	200	250	315	375	
Max. pressure drop	bar [psi]	cont.	140 [2030]	175 [2540]	175 [2540]	175 [2540]	175 [2540]	175 [2540]	175 [2540]	135 [1960]	115 [1670]	
		int. ¹⁾	175 [2540]	200 [2900]	200 [2900]	200 [2900]	200 [2900]	200 [2900]	200 [2900]	200 [2900]	175 [2540]	150 [2180]
		peak ²⁾	225 [3260]	225 [3260]	225 [3260]	225 [3260]	225 [3260]	225 [3260]	225 [3260]	225 [3260]	210 [3050]	175 [2540]
Max. oil flow	l/min [US gal/min]	cont.	40 [10.6]	60 [15.9]	60 [15.9]	60 [15.9]	60 [15.9]	60 [15.9]	60 [15.9]	60 [15.9]	60 [15.9]	
		int. ¹⁾	50 [13.2]	75 [19.8]	75 [19.8]	75 [19.8]	75 [19.8]	75 [19.8]	75 [19.8]	75 [19.8]	75 [19.8]	
Max. starting pressure with unloaded shaft	bar [psi]		10 [145]	10 [145]	10 [145]	9 [130]	7 [100]	5 [75]	5 [75]	5 [75]	5 [75]	
Min starting torque	at max. press drop cont. N·m [lbf·in]		80 [710]	150 [1330]	200 [1770]	250 [2210]	320 [2830]	410 [3630]	500 [4430]	500 [4430]	470 [4170]	
	at max. press.drop int. ¹⁾ N·m [lbf·in]		100 [890]	170 [1510]	230 [2040]	280 [2480]	370 [3280]	460 [4070]	550 [4870]	660 [5840]	570 [5050]	

¹⁾ Intermittent operation: the permissible values may occur for max. 10% of every minute.

²⁾ Peak load: the permissible values may occur for max. 1% of every minute.

Type		Max. inlet pressure	Max.return pressure with drain line
OMR 50 - 375	bar [psi] cont	175 [2540]	175 [2540]
	bar int. ¹⁾ [psi]	200 [2900]	200 [2900]
	bar peak ²⁾ [psi]	225 [3260]	225 [3260]

¹⁾ Intermittent operation: the permissible values may occur for max. 10% of every minute.

²⁾ Peak load: the permissible values may occur for max. 1% of every minute.

Technical Data for Parking Brake Motor OMR F, OMR NF and OMRW NF

Technical data for brake motor		
Holding torque 1)	N·m [lbf·in]	400 [3540]
Min. release pressure 2)	bar [psi]	21 [305]
Max. pressure in brake line	bar [psi]	200 [2900]

1) This brake is to be used only as a passive parking brake. It may not be used for dynamic braking.
2) Brake motors must always have a drain line. The brake release pressure is the difference between the pressure in the brake release line and the pressure in the drain line.

Function

In normal condition where there is no pressure on the integrated brake in OMR, i.e. the brake is applied. The brake is released when hydraulic pressure of 21 bar [300psi] min. is applied to the brake release port (1).

Technical Data

The pressure forces the piston (2) against the springs (3 and 4) disengaging the outer and inner discs (5 and 6) from each other so that the cardan shaft (7) and consequently output shaft (8) become free to rotate.

If the pressure on the brake release port is reduced to less than 21 bar [300psi], the springs force the piston and pressure pad (9) against the brake discs and the cardan shaft/output shaft begin to lock up.

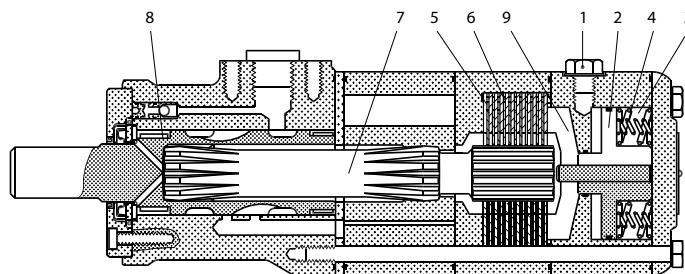

151-1739.10.10

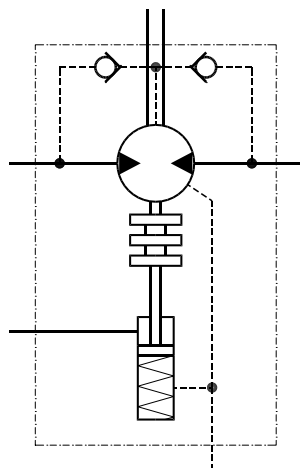

151-1726.10

Technical Data - Max. Permissible Shaft Seal Pressure

OMR with High Pressure Shaft Seal (HPS)

OMR with HPS, without check valves and without drain connection:

The shaft seal pressure equals the average of input pressure and return pressure

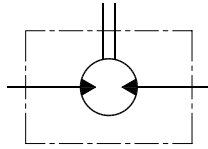

151-1743.10

$$P_{\text{seal}} = \frac{P_{\text{in}} + P_{\text{return}}}{2}$$

OMR with HPS, check valves and with drain connection:

The shaft seal pressure equals the pressure in the drain line.

OMR with HPS, check valves and without drain connection:

The pressure on the shaft seal never exceeds the pressure in the return line.

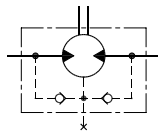

151-320.10

Max. permissible shaft seal pressure

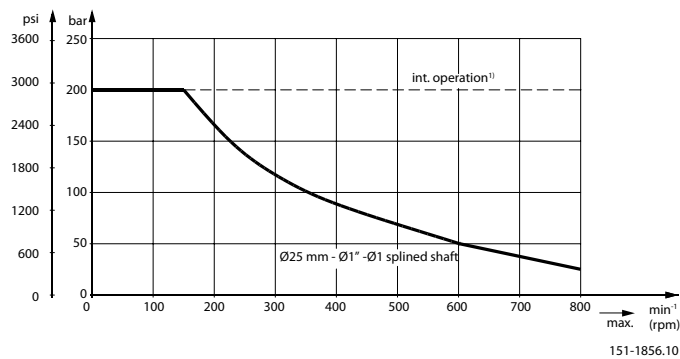

151-1856.10

OMR with Standard Shaft Seal

OMR with standard shaft seal, check valves and without use of drain connection:

The pressure on the shaft seal never exceeds the pressure in the return line

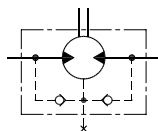

151-320.10

OMR with standard shaft seal, check valves and with drain connection:

Technical Data - Max. Permissible Shaft Seal Pressure

The shaft seal pressure equals the pressure on the drain line.

Max. return pressure without drain line or max. pressure in the drain line

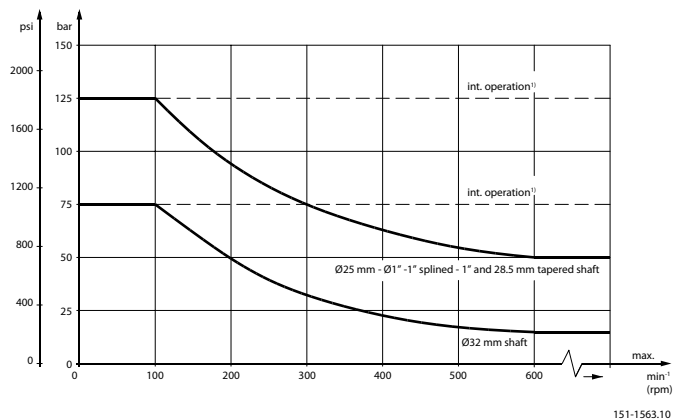

1) Intermittent operation: the permissible values may occur for max. 10% of every minute.

Technical Data

Pressure Drop in Motor

The curve applies to an unloaded motor shaft and an oil viscosity of 35 mm²/s [165 SUS]

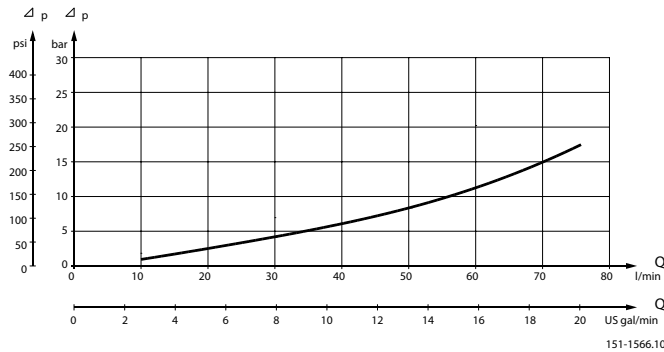

Oil flow in drain line

The table shows the max. oil flow in the drain line at a return pressure less than 5-10 bar [75-150 psi].

Pressure drop bar [psi]	Viscosity mm ² /s [SUS]	Oil flow in drain line l/min [US gal/min]
100 [1450]	20 [100]	2.5 [0.66]
	35 [165]	1.8 [0.78]
140 [2030]	20 [100]	3.5 [0.93]
	35 [165]	2.8 [0.74]

Direction of Shaft Rotation

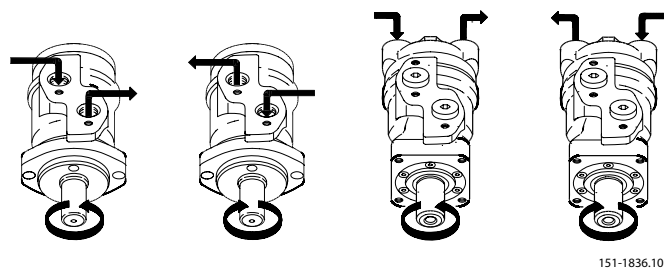

Permissible Shaft Loads for OMR

The permissible radial shaft load (PR) depends on

- Speed (n)
- Distance (L) from the point of load to the mounting flange
- Mounting flange version
- Shaft version

Mounting flange	4-oval flange** 2-hole oval flange (European version)	4-hole oval flange	Square flange** 2-hole oval flange (US-version)

Technical Data

Shaft version	25 mm cylindrical shaft 1 in cylindrical shaft 1 in splined shaft	32 mm cylindrical shaft	25 mm cylindrical shaft
Permissible shaft load (PR) - I in mm	800 250000 N* n 95 + L	800 187500 N* n 95 + L	800 250000 N* n 101 + L
Permissible shaft load (PR) - I in inch	800 2215 lbf* n 3.74 + L	800 1660 lbf* n 3.74 + L	800 2215 lbf* n 3.98 + L

* $n \geq 200 \text{ min}^{-1}$ [rpm]; $\leq 55 \text{ mm}$ [2.2 in]
 $n < 200 \text{ min}^{-1}$ [rpm]; $= > \text{PR}_{\text{max}} = 8000 \text{ N}$ [1800 lbf]
 ** For both European and US-version

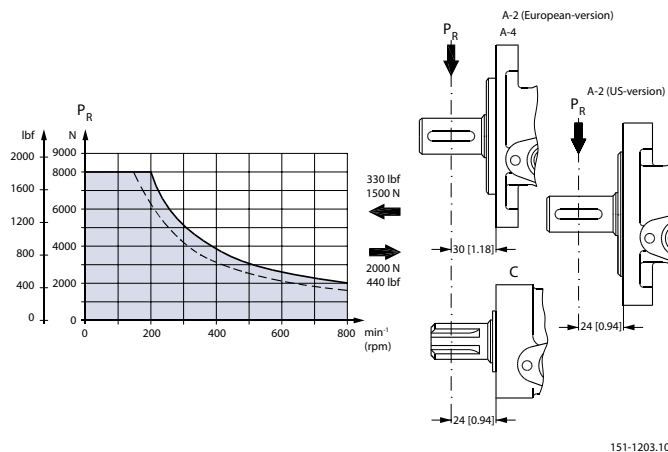

----- cylindrical shaft 32 mm [1.26 in]

_____ other shaft versions

The curve shows the relation between PR and n

- when $l = 30 \text{ mm}$ [1.18 in] for motors with A2 (European version) and A4 oval mounting flange
- when $l = 24 \text{ mm}$ [0.94 in] for motors with square mounting flange and A2 (US version)
- (US version)

For applications with special performance requirements we recommend OMR with the output shaft running in needle bearings.

Permissible Shaft Load for OMR N and OMR NF with Needle Bearings

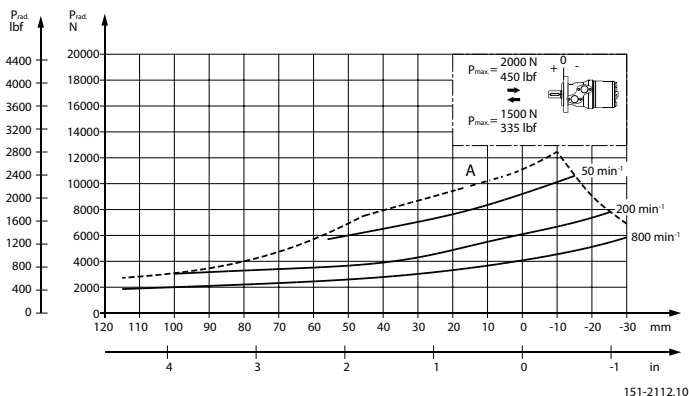

Technical Data

The output shaft on OMR N and OMR NF runs in needle bearings. These bearings and the recessed mounting flange allow a higher permissible radial load in comparison to OMR motors with slide bearings.

The permissible radial load on the shaft is shown for different speeds as a function of the distance from the mounting flange to the point of load application.

Curve A shows max. radial shaft load. Any shaft load exceeding the values quoted in the curve will involve a risk of breakage.

The other curves apply to a B10 bearing life of 2000 hours at the number of revolutions indicated by the curve letter. Mineral based hydraulic oil with a sufficient content of anti-wear additives must be used.

Bearing life calculations can be made using the explanation and formula provided in the chapter »Bearing dimensioning« in the technical information "General" DHMH.PK.100.G2.02 520L0232.

Permissible Shaft Load for OMRW N and OMRW NF with Needle Bearings

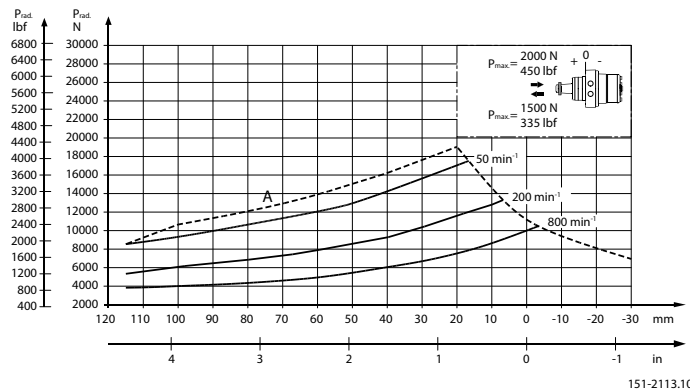

The output shaft on OMRW N runs in needle bearings. These bearings and the recessed mounting flange allow a higher permissible radial load in comparison to OMR motors with slide bearings.

The permissible radial load on the shaft is shown for different speeds as a function of the distance from the mounting flange to the point of load application.

Curve A shows max. radial shaft load. Any shaft load exceeding the values quoted in the curve will involve a risk of breakage.

The other curves apply to a B10 bearing life of 2000 hours at the number of revolutions indicated by the curve letter. Mineral based hydraulic oil with a sufficient content of anti-wear additives must be used.

Bearing life calculations can be made using the explanation and formula provided in the chapter »Bearing dimensioning« in the technical information "General" DHMH.PK.100.G2.02 520L0232.

Technical Information Orbital Motors Type OMP, OMR and OMH

Function Diagrams

Function Diagrams

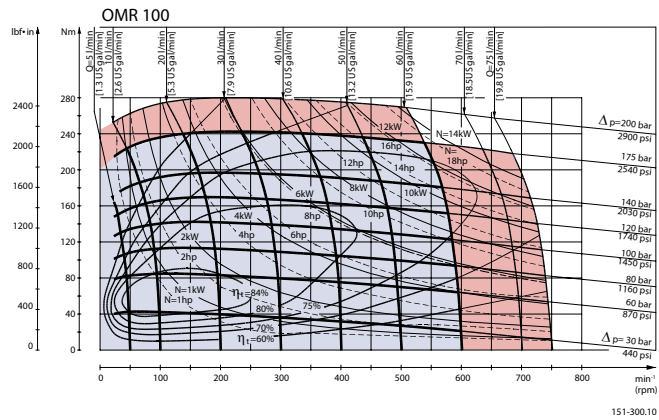
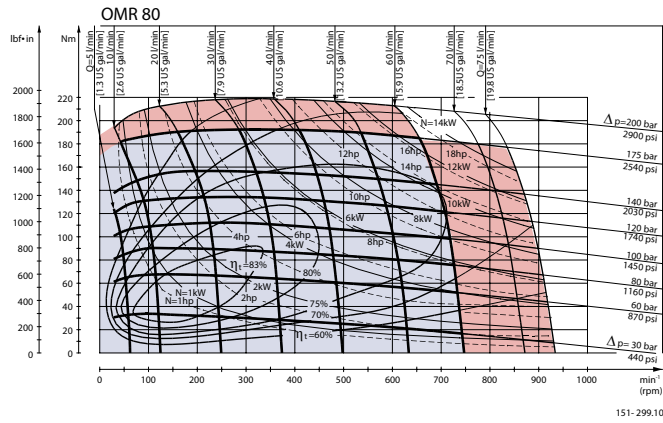
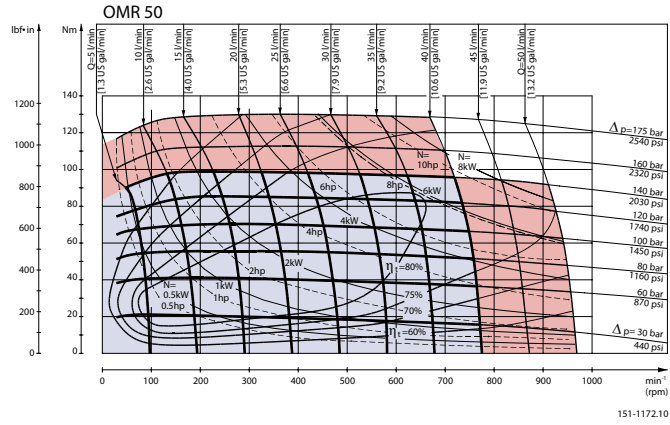

Function Diagrams

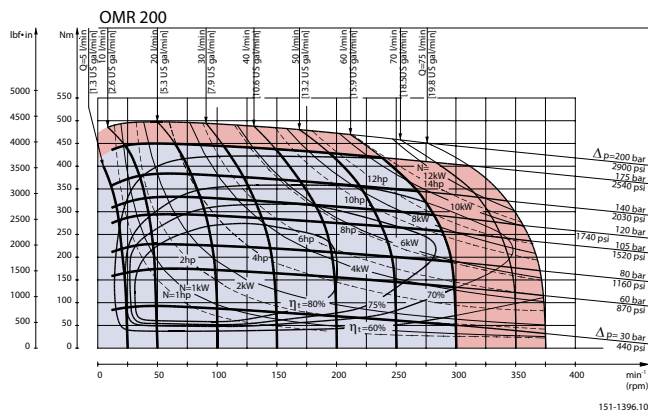
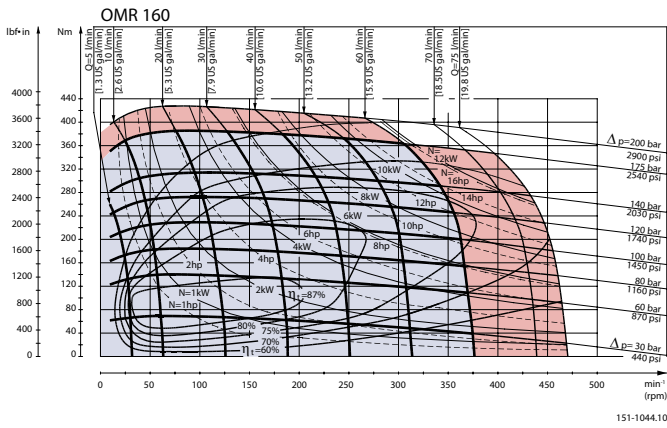
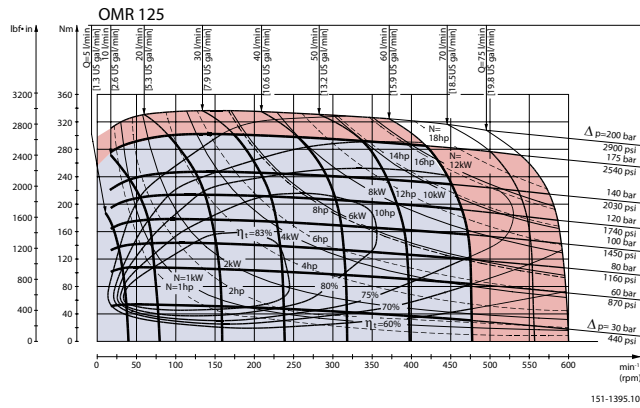

Function Diagrams

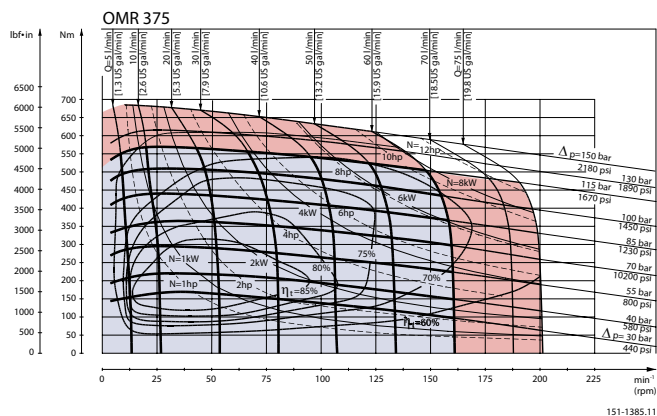
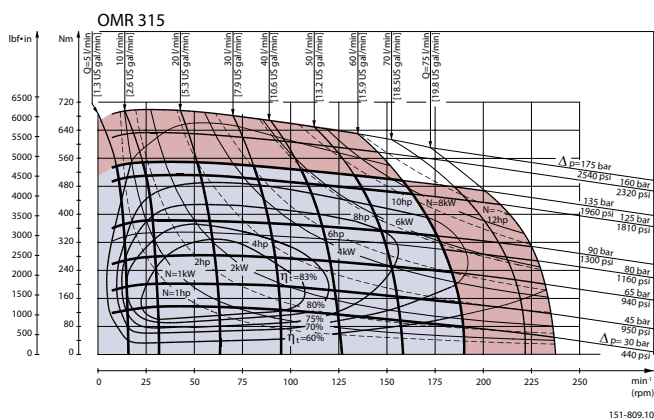
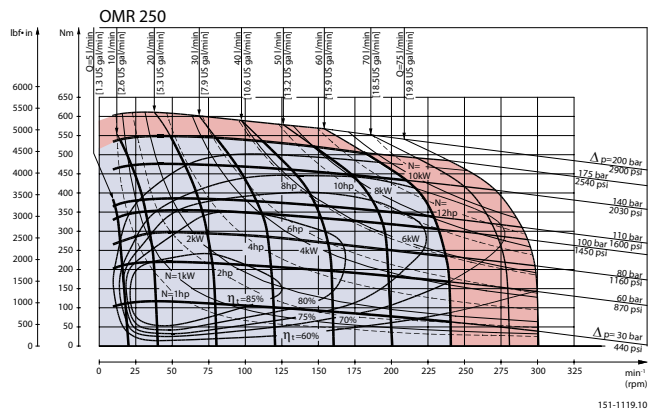

Explanation of function diagram use, basis and conditions can be found in [Speed, Torque and Output](#) on page 8.

- Continuous range
- Intermittent range (max. 10% operation every minute)

Max. permissible continuous/intermittent pressure drop for the actual shaft version can be found in [Technical data for OMR with 25 mm and 1 in cylindrical shaft](#) on page 42.

Intermittent pressure drop and oil flow must not occur simultaneously.

Shaft Version

Shaft Version

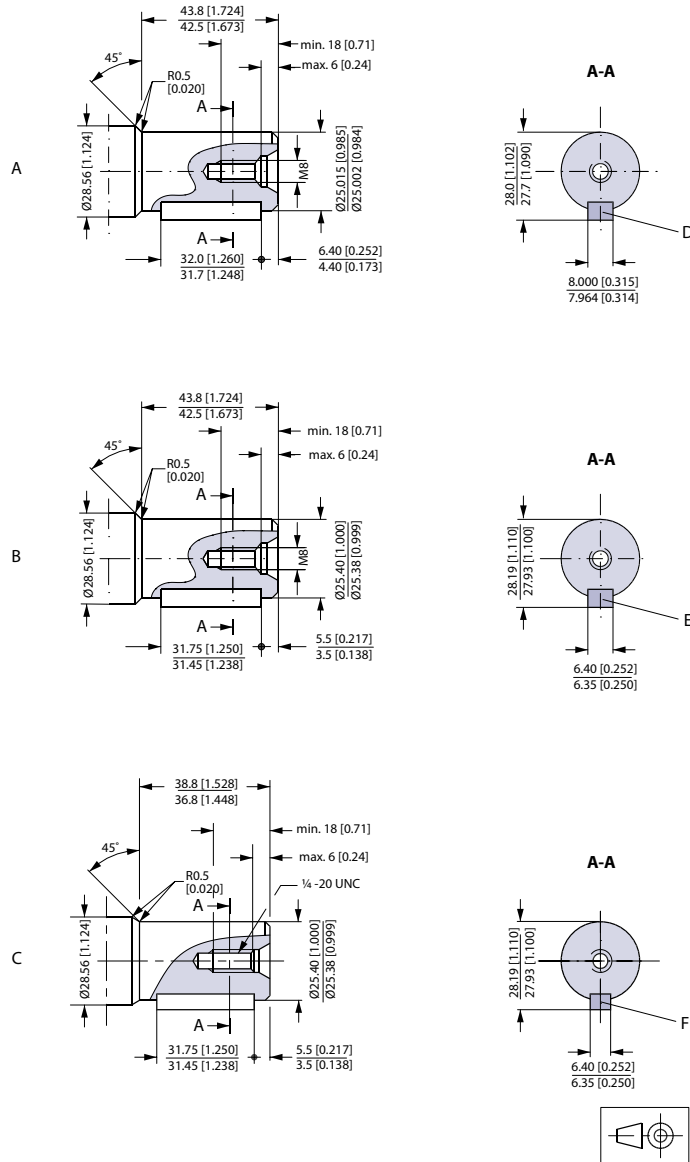

A: Cylindrical shaft
25 mm

B: Cylindrical shaft 1 in

US version

C: Cylindrical shaft
1 in

D: Parallel key
A8 • 7 • 32
DIN 6885

E: Parallel key
1/4 • 1/4 • 1 1/4 in
B.S. 46

F: Parallel key
1/4 • 1/4 • 1 1/4 in
B.S. 46

151-1846.12

Shaft Version

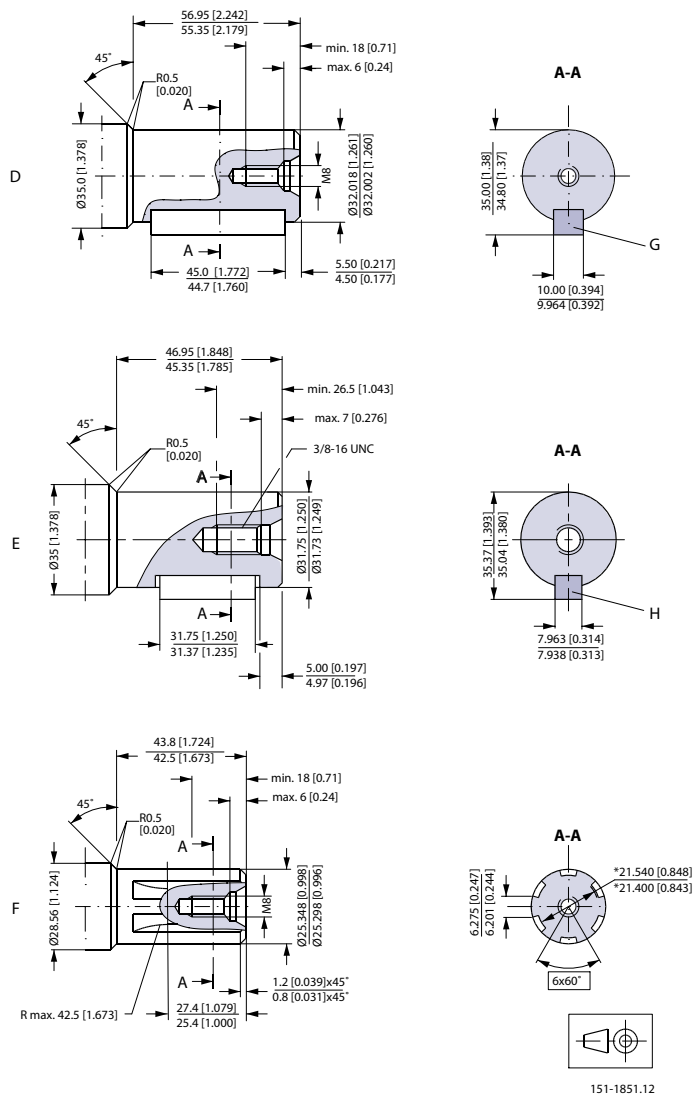

D: Cylindrical shaft
32 mm

G: Parallel key
A10 • 8 • 45
DIN 6885

US version

E: Cylindrical shaft
1 ¼ in

H: Parallel key
5/16 5/16 1 ¼ in
B.S. 46

F: Involute splined shaft
B.S. 2059 (SAE 6 B)
Straight-sided,
bottom fitting, deep.
Fit 2
Nom. size 1 in
*Deviates from
B.S. 2059 (SAE 6 B)

151-1851.12

Shaft Version

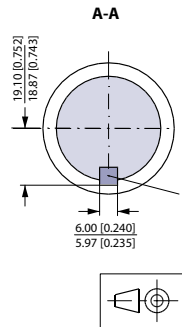
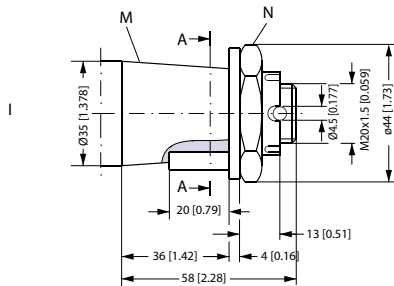
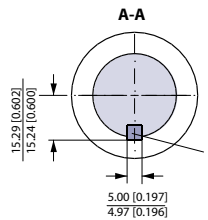
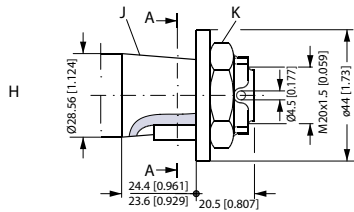
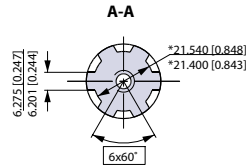
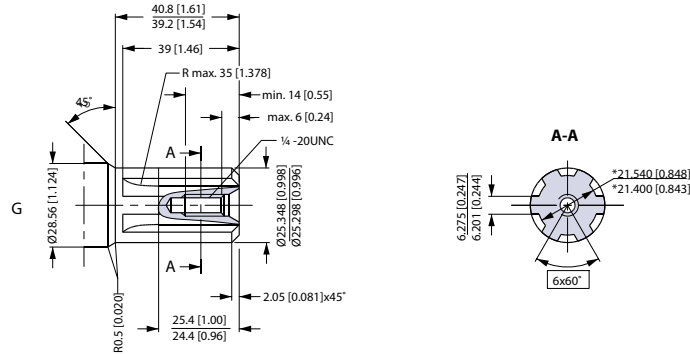

151-1847.11

US version

G: Splined shaft
SAE 6 B (B.S. 2059)
Straight-sided,
bottom fitting, deep.
Fit 2; Nom. size 1 in
* Deviates from SAE 6 B (B.S. 2059)

H: Tapered shaft 28.5 mm
(ISO/R775)

I: Tapered shaft 35 mm

K: DIN 937
NV 30
Tightening torque:
100 ± 10 N·m
[885 ± 85 lbf·in]

J: Taper 1:10

M: Taper 1:10

L: Parallel key
B5 • 5 • 14
DIN 6885

P: Parallel key
B6 • 6 • 20
DIN 6885

N: DIN 937
NV 41
Tightening torque:
200 ± 10 N·m [1770 ± 85 lbf·in]

Shaft Version

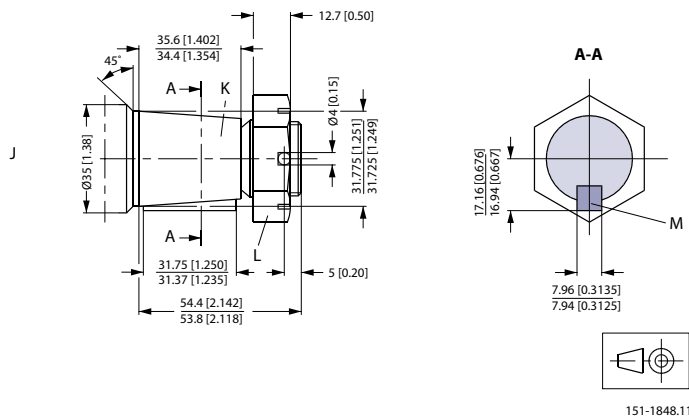

J: Tapered shaft 1 1/4 in

L: 1 - 20 UNEF
 Across flats 1 7/16
 Tightening torque:
 200 ± 10 Nm [1770 ± 85 lbf-in]

K: Cone 1:8
 SAE J501

M: Parallel key
 5/16 • 5/16 • 1 1/4
 SAE J501

Port Thread Versions

Port Thread Versions

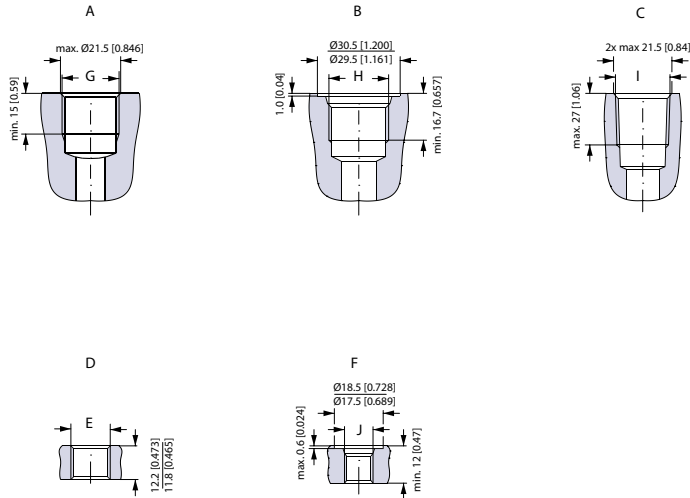

151-1844.11

A: G main ports

B: UNF main ports

C: NPTF main ports

G: ISO 228/1 - G½

H: 7/8 - 14 UNF
O-ring boss port

I: ½ - 14 NPTF

D: G drain port

F: UNF drain port

E: ISO 228/1 - G¼

J: 7/16 - 20 UNF

O-ring boss port

Manifold Mount

European version

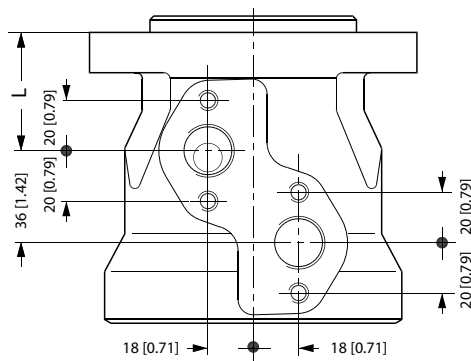

151-2135.10

L: see dimensional drawing for given OMR motor: [Dimensions-European version](#) on page 59 and [Dimension-US Version](#) on page 65

Dimensions-European version

Dimensions

Side port version with 2-hole oval mounting flange (A2 flange). With high pressure shaft seal

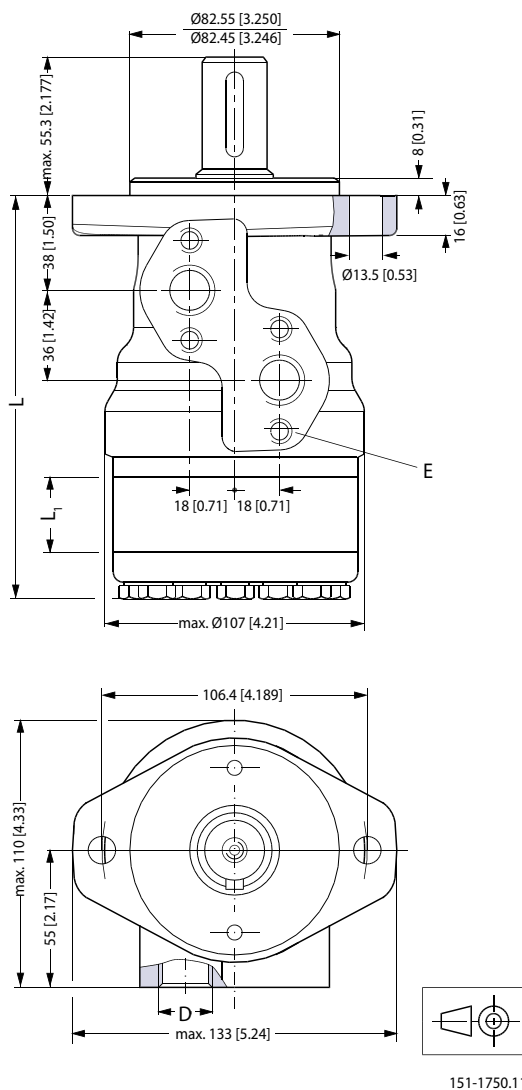

D: G ½; 15 mm [0.59 in] deep

E: M8; 13 mm [0.51 in] deep
(4 pcs.)

Type	Max. L		L1	
	mm	[in]	mm	[in]
OMR 50	136.5	[5.37]	9.0	[0.35]
OMR 80	141.5	[5.57]	14.0	[0.55]
OMR 100	145.0	[5.71]	17.4	[0.69]
OMR 125	149.5	[5.89]	21.8	[0.86]
OMR 160	155.5	[6.12]	27.8	[1.09]
OMR 200	162.5	[6.40]	34.8	[1.37]

Dimensions-European version

Type	Max. L		L1	
	mm	[in]	mm	[in]
OMR 250	171.5	[6.75]	43.5	[1.71]
OMR 315	182.5	[7.19]	54.8	[2.16]
OMR 375	192.7	[7.59]	65.0	[2.56]

Side port version with 2-hole oval mounting flange (A2 flange). With check valves and drain connection. With high pressure shaft seal.

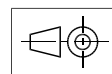
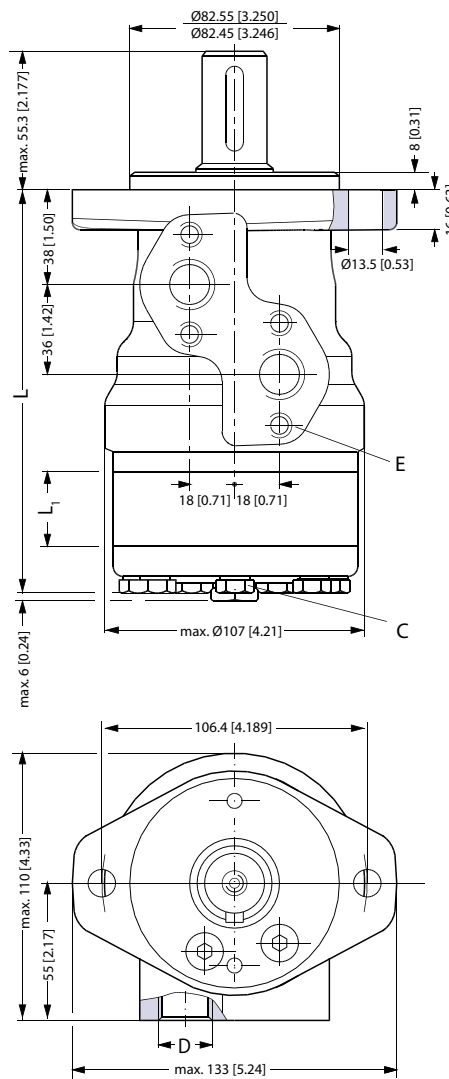

151-1845.11

C: Drain connection

G 1/2; 15 mm [0.47 in] deep

E: M8; 13 mm [0.51 in] deep

(4 pcs.)

D: G 1/2; 15 mm [0.59 in] deep

Dimensions-European version

Type	Max. L		L1	
	mm	[in]	mm	[in]
OMR 50	136.5	[5.37]	9.0	[0.35]
OMR 80	141.5	[5.57]	14.0	[0.55]
OMR 100	145.0	[5.71]	17.4	[0.69]
OMR 125	149.5	[5.89]	21.8	[0.86]
OMR 160	155.5	[6.12]	27.8	[1.09]
OMR 200	162.5	[6.40]	34.8	[1.37]
OMR 250	171.5	[6.75]	43.5	[1.71]
OMR 315	182.5	[7.19]	54.8	[2.16]
OMR 375	192.7	[7.59]	65.0	[2.56]

OMR, OMR C and OMR N Side port version with 2-hole oval mounting flange (A2 flange)

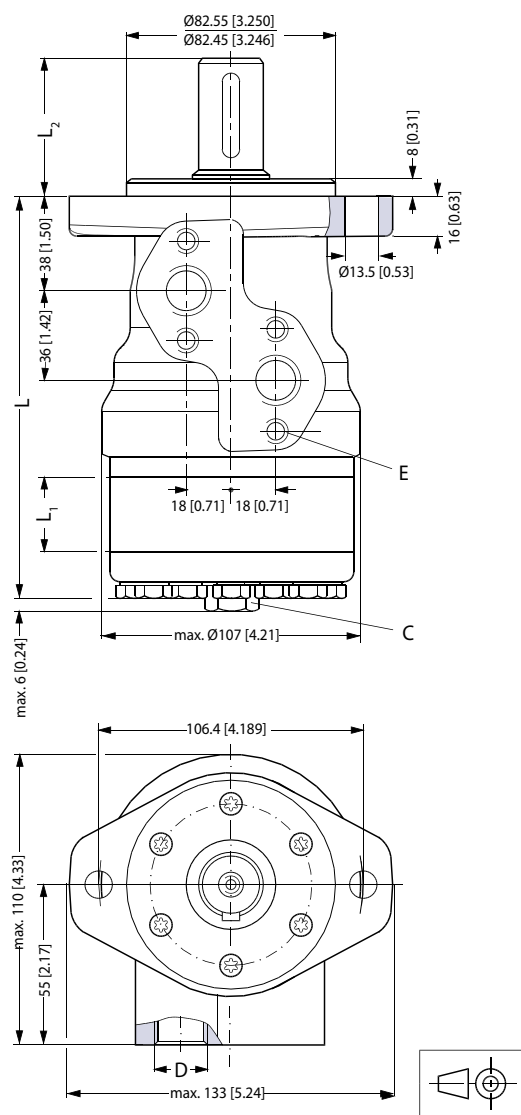

151-1849.13

Technical Information Orbital Motors Type OMP, OMR and OMH

Dimensions-European version

C: Drain connection
G ¼; 12 mm [0.47 in] deep

D: G ½; 15 mm [0.59 in] deep

E: M8; 13 mm [0.51 in] deep
(4 pcs.)

Output shaft.max.	L2	
	mm	[in]
Cylindrical shaft 32 mm [1.26 in]	68.3	[2.69]
Cylindrical shaft 25 mm [0.98 in]	55.3	[2.18]
Tapered shaft 28.56 mm [1.12 in]	56.3	[2.19]

Type	Max. L		L1	
	mm	[in]	mm	[in]
OMR 50	136.5	[5.37]	9.0	[0.35]
OMR 80	141.5	[5.57]	14.0	[0.55]
OMR 100	145.0	[5.71]	17.4	[0.69]
OMR 125	149.5	[5.89]	21.8	[0.86]
OMR 160	155.5	[6.12]	27.8	[1.09]
OMR 200	162.5	[6.40]	34.8	[1.37]
OMR 250	171.5	[6.75]	43.5	[1.71]
OMR 315	182.5	[7.19]	54.8	[2.16]
OMR 375	192.7	[7.59]	65.0	[2.56]

Dimensions-European version

End port version with 2-hole oval mounting flange (A2-flange)

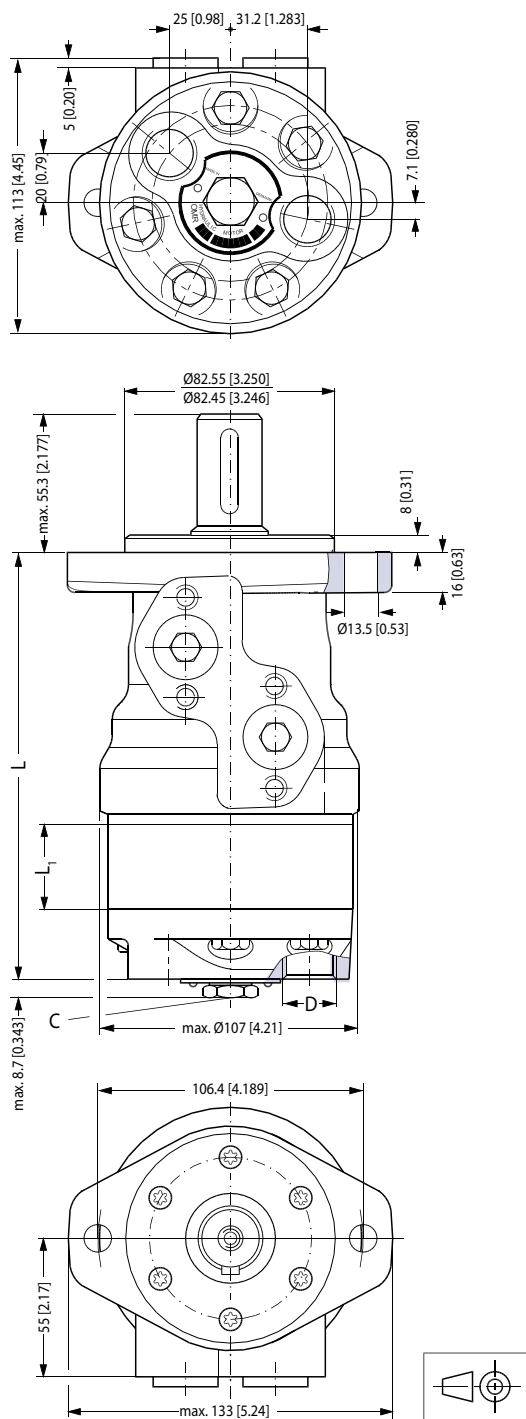

C: G ¼; 12 mm [0.47 in] deep

D: G ½; 15 mm [0.59 in] deep

Technical Information Orbital Motors Type OMP, OMR and OMH

Dimensions-European version

Type	Max. L		L1	
	mm	[in]	mm	[in]
OMR 50	151.6	[5.96]	9.0	[0.35]
OMR 80	156.6	[6.17]	14.0	[0.55]
OMR 100	160.0	[6.30]	17.4	[0.69]
OMR 125	164.4	[6.47]	21.8	[0.86]
OMR 160	170.4	[6.71]	27.8	[1.09]
OMR 200	177.4	[6.98]	34.8	[1.37]
OMR 250	186.1	[7.33]	43.5	[1.71]
OMR 315	197.4	[7.77]	54.8	[2.16]
OMR 375	207.6	[8.17]	65.0	[2.56]

Technical Information Orbital Motors Type OMP, OMR and OMH

Dimension-US Version

Type	Max. L mm [in]	L1 mm [in]
OMR 160	161.5 [6.36]	27.8 [1.09]
OMR 200	168.5 [6.63]	34.8 [1.37]
OMR 250	177.5 [6.99]	43.5 [1.71]
OMR 315	188.5 [7.42]	54.8 [2.16]
OMR 375	198.5 [7.82]	64.8 [2.56]

Dimensions-European Version

Dimensions

Side port version with 4-hole oval mounting flange (A4 flange)

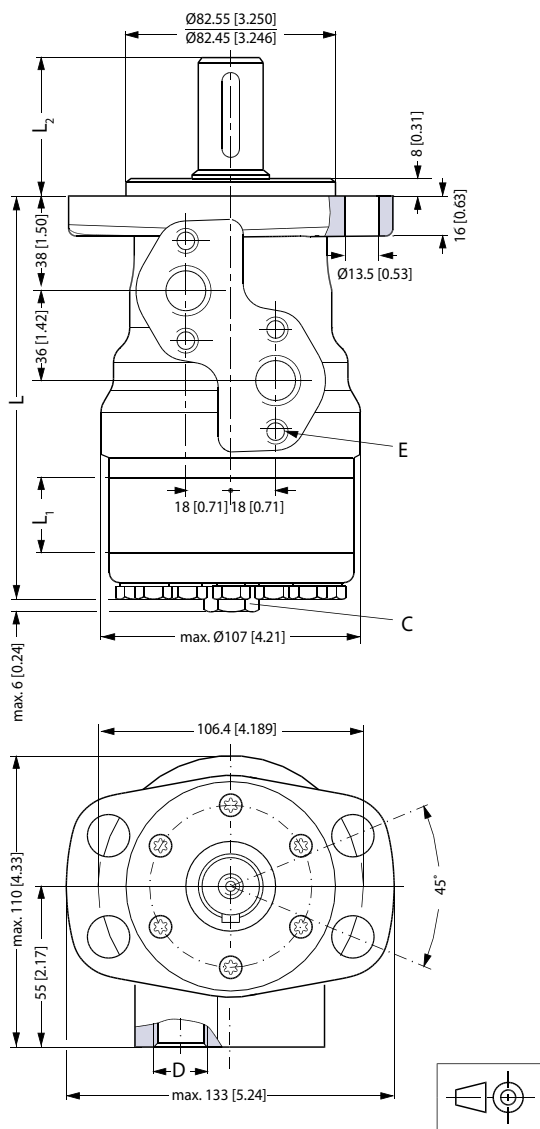

151-1751.11

C: Drain connection

G ¼; 15 mm [0.47 in] deep

E: M8; 13 mm [0.51 in] deep

(4 pcs.)

D: G ½; 15 mm [0.59 in] deep

Output shaft.max.	L2 mm [in]
Cylindrical shaft 32 mm [1.26 in]	68.3 [2.69]
Cylindrical shaft 25 mm [0.98 in]	55.3 [2.18]
Tapered shaft 28.56 mm [1.12 in]	56.3 [2.19]

Dimensions-European Version

Type	Max. L mm [in]	L1 mm [in]
OMR 50	136.5 [5.37]	9.0 [0.35]
OMR 80	141.5 [5.57]	14.0 [0.55]
OMR 100	145.0 [5.71]	17.4 [0.69]
OMR 125	149.5 [5.89]	21.8 [0.86]
OMR 160	155.5[6.12]	27.8 [1.09]
OMR 200	162.5 [6.40]	34.8 [1.37]
OMR 250	171.5 [6.75]	43.5 [1.71]
OMR 315	182.5[7.19]	54.8 [2.16]
OMR 375	192.7 [7.59]	65.0 [2.56]

Dimensions-US Version

Dimensions

Side port version with 4-hole oval mounting flange (A4-flange)

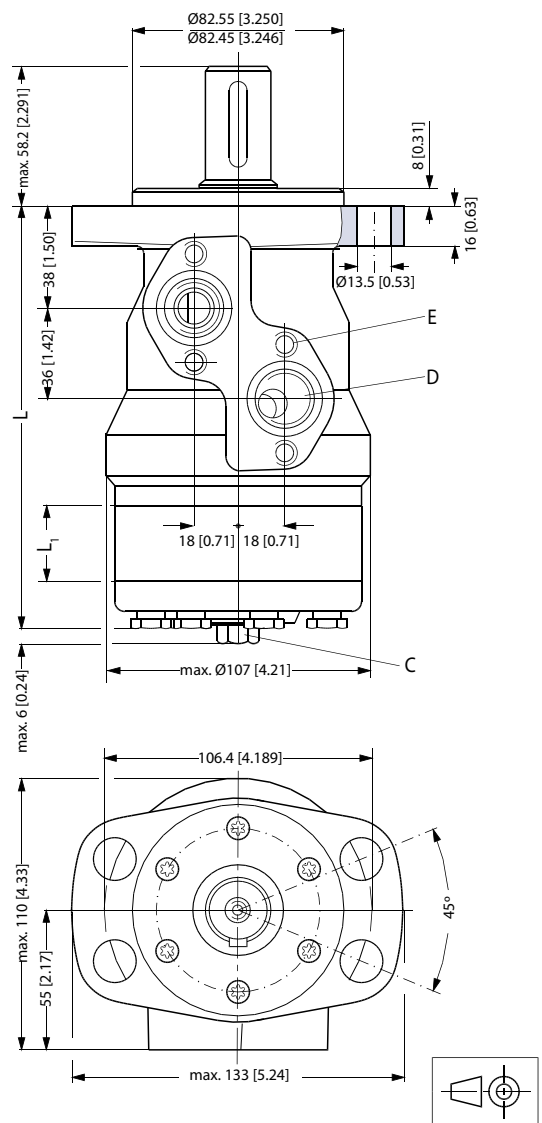

151-1221.11

C: Drain connection
7/16 - 20 UNF;
12 mm [0.47 in] deep

D: 7/8 - 14 UNF;
17 mm [0.66 in] deep

E: M8; 13 mm [0.51 in] deep (4-off)

Type	Max. L mm [in]	L1 mm [in]
OMR 50	136.5 [5.37]	9.0 [0.35]
OMR 80	141.5 [5.57]	14.0 [0.55]
OMR 100	145.0 [5.71]	17.4 [0.69]

Technical Information Orbital Motors Type OMP, OMR and OMH

Dimensions-US Version

Type	Max. L mm [in]	L1 mm [in]
OMR 125	149.5 [5.89]	21.8 [0.86]
OMR 160	155.5 [6.12]	27.8 [1.09]
OMR 200	162.5 [6.40]	34.8 [1.37]
OMR 250	171.5 [6.75]	43.5 [1.71]
OMR 315	182.5 [7.19]	54.8 [2.16]
OMR 375	192.7 [7.59]	65.0 [2.56]

Dimensions-European Version

Dimensions

End port version with square mounting flange (C-flange)

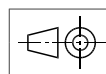
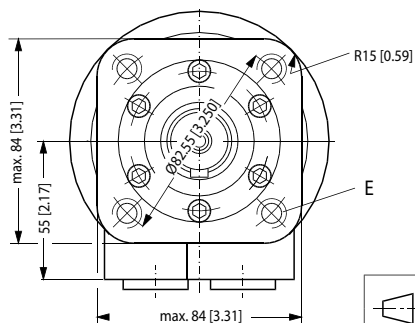
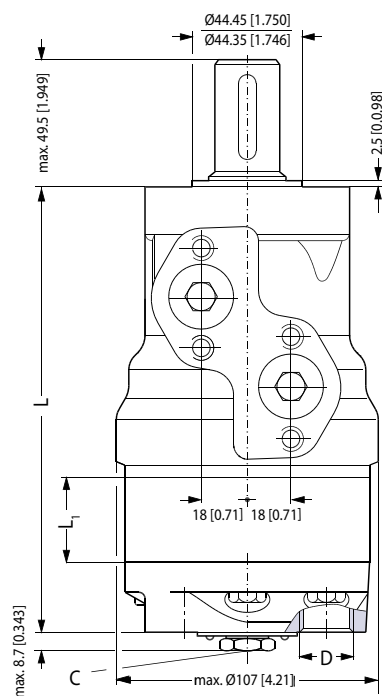
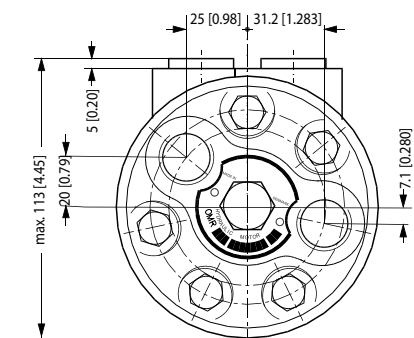

151-1753.11

C: Drain connection
G ¼; 12 mm [0.47 in] deep

D: G ½; 15 mm [0.59 in] deep

E: M10; 15 mm [0.59 in] deep
(4 pcs.)

Dimensions-European Version

Type	Max. L mm [in]	L1 mm [in]
OMR 50	157.6 [6.21]	9.0 [0.35]
OMR 80	162.6 [6.40]	14.0 [0.55]
OMR 100	166.0 [6.54]	17.4 [0.69]
OMR 125	170.4 [6.71]	21.8 [0.86]
OMR 160	176.4 [6.95]	27.8 [1.09]
OMR 200	183.4 [7.22]	34.8 [1.37]
OMR 250	192.1 [7.56]	43.5 [1.71]
OMR 315	203.4 [8.02]	54.8 [2.16]
OMR 375	213.5 [8.41]	65.0 [2.56]

Dimensions-US Version

Dimensions

Side port version with square mounting flange (C-flange)

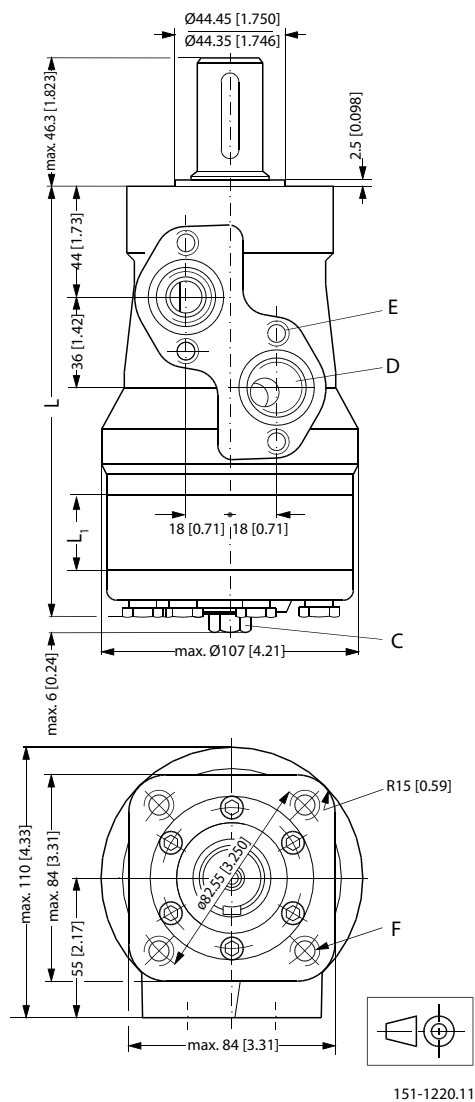

C: Drain connection
7/16 - 20 mm UNF;
12 mm [0.47 in] deep

E: M8; 13 mm [0.51 in] deep (4-off)

D: 7/8 - 14 UNF;
17 mm [0.66 in] deep

F: 3/8 - 16 UNC;
15 mm [0.59 in] deep (4-off)

Type	Max. L mm [in]	L1 mm [in]
OMR 50	142.5 [5.61]	9.0 [0.35]
OMR 80	147.5 [5.81]	14.0 [0.55]
OMR 100	151.0 [5.95]	17.4 [0.69]
OMR 125	155.4 [6.12]	21.8 [0.86]

Technical Information Orbital Motors Type OMP, OMR and OMH

Dimensions-US Version

Type	Max. L mm [in]	L1 mm [in]
OMR 160	161.5 [6.36]	27.8 [1.09]
OMR 200	168.5 [6.63]	34.8 [1.37]
OMR 250	177.5 [6.99]	43.5 [1.71]
OMR 315	188.5 [7.42]	54.8 [2.16]
OMR 375	198.7 [7.82]	65.0 [2.56]

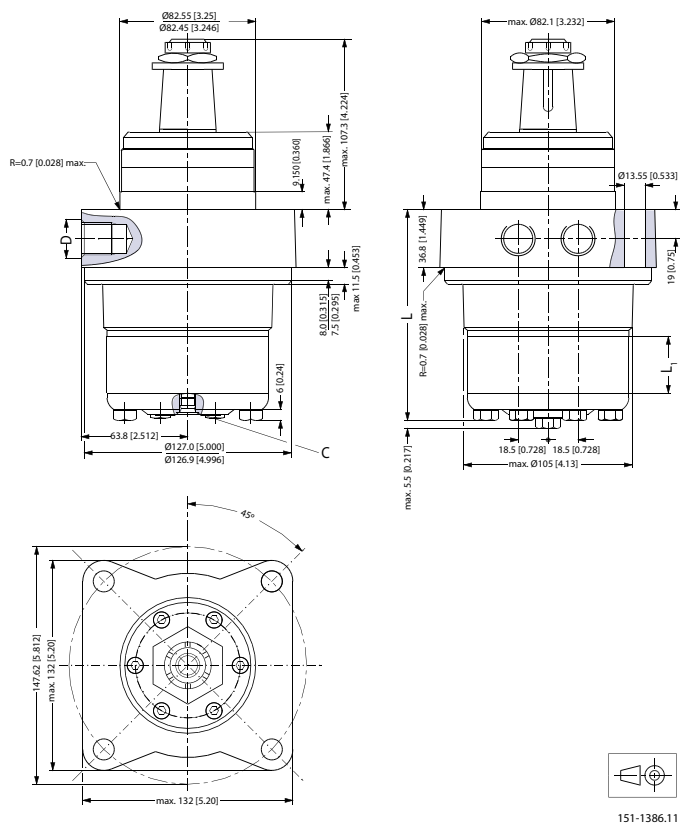
Dimensions-European Version
Dimensions
OMRW N wheel motor

C: Drain connection
G $\frac{1}{4}$; 12 mm [0.47 in] deep

D: G $\frac{1}{2}$; 15 mm [0.59 in] deep

Type	Max. L mm [in]	L1 mm [in]
OMRW 50 N	107.0 [4.21]	9.0 [0.35]
OMRW 80 N	112.0 [4.41]	14.0 [0.55]
OMRW 100 N	115.4 [4.54]	17.4 [0.69]
OMRW 125 N	119.8 [4.72]	21.8 [0.86]
OMRW 160 N	125.8 [4.95]	27.8 [1.09]
OMRW 200 N	132.8 [5.23]	34.8 [1.37]
OMRW 250 N	141.5 [5.57]	43.5 [1.71]
OMRW 315 N	153.0 [6.02]	54.8 [2.16]
OMRW 375 N	163.0 [6.42]	65.0 [2.56]

Dimensions-US Version

Dimensions

OMRW N wheel motor

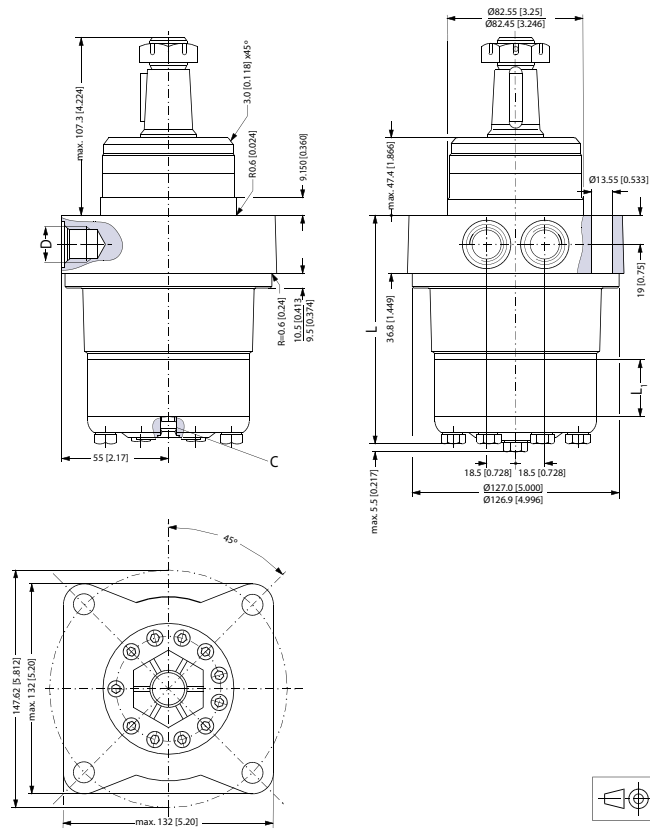

C: Drain connection
7/16 - 20 UNF;
12 mm [0.47 in] deep

D: 7/8 - 14 UNF;
17 mm [0.66 in] deep

Type	Max. L mm [in]	L1 mm [in]
OMRW 50 N	107.0 [4.21]	9.0 [0.35]
OMRW 80 N	112.0 [4.41]	14.0 [0.55]
OMRW 100 N	115.4 [4.54]	17.4 [0.69]
OMRW 125 N	119.8 [4.72]	21.8 [0.86]
OMRW 160 N	125.8 [4.95]	27.8 [1.09]
OMRW 200 N	132.8 [5.23]	34.8 [1.37]
OMRW 250 N	141.5 [5.57]	43.5 [1.71]
OMRW 315 N	153.0 [6.02]	54.8 [2.16]
OMRW 375 N	163.0 [6.42]	65.0 [2.56]

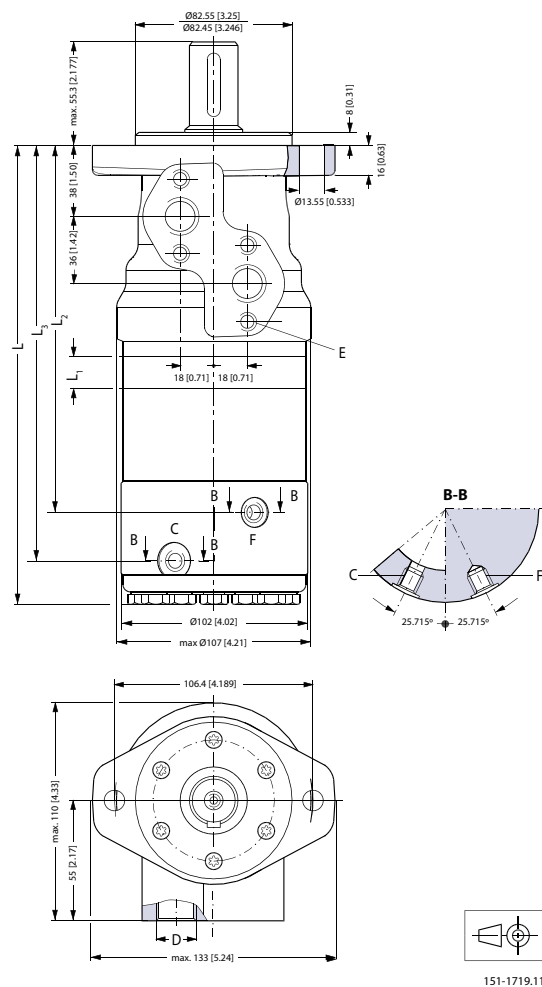
Dimensions-European Version
Dimensions
OMR F motor

C: Drain connection
G ¼; 12 mm [0.47 in] deep

E: M8; 13 mm [0.51 in] deep

D: G ½; 15 mm [0.59 in] deep

F: Brake release connection G ¼

Type	Max. L mm [in]	L1 mm [in]	L2 mm [in]	L3 mm [in]
OMR 80 F	241.3 [9.50]	14.0 [0.55]	187.3 [7.37]	210.8 [8.30]
OMR 100 F	244.7[9.63]	17.4 [0.69]	190.7 [7.51]	214.2 [8.43]
OMR 125 F	249.1 [9.81]	21.8 [0.86]	195.1 [7.68]	218.6 [8.61]
OMR 160 F	255.1 [10.04]	27.8 [1.09]	201.1 [7.92]	224.6 [8.84]
OMR 200 F	262.1 [10.32]	34.8 [1.37]	208.1 [8.19]	231.6 [9.12]
OMR 250 F	270.8 [10.66]	43.5 [1.71]	216.8 [8.54]	240.3 [9.46]
OMR 315 F	282.1 [11.11]	54.8 [2.16]	228.1 [8.98]	251.6 [9.91]
OMR 375 F	292.3 [11.51]	65.0 [2.56]	238.3 [9.38]	261.8 [10.31]

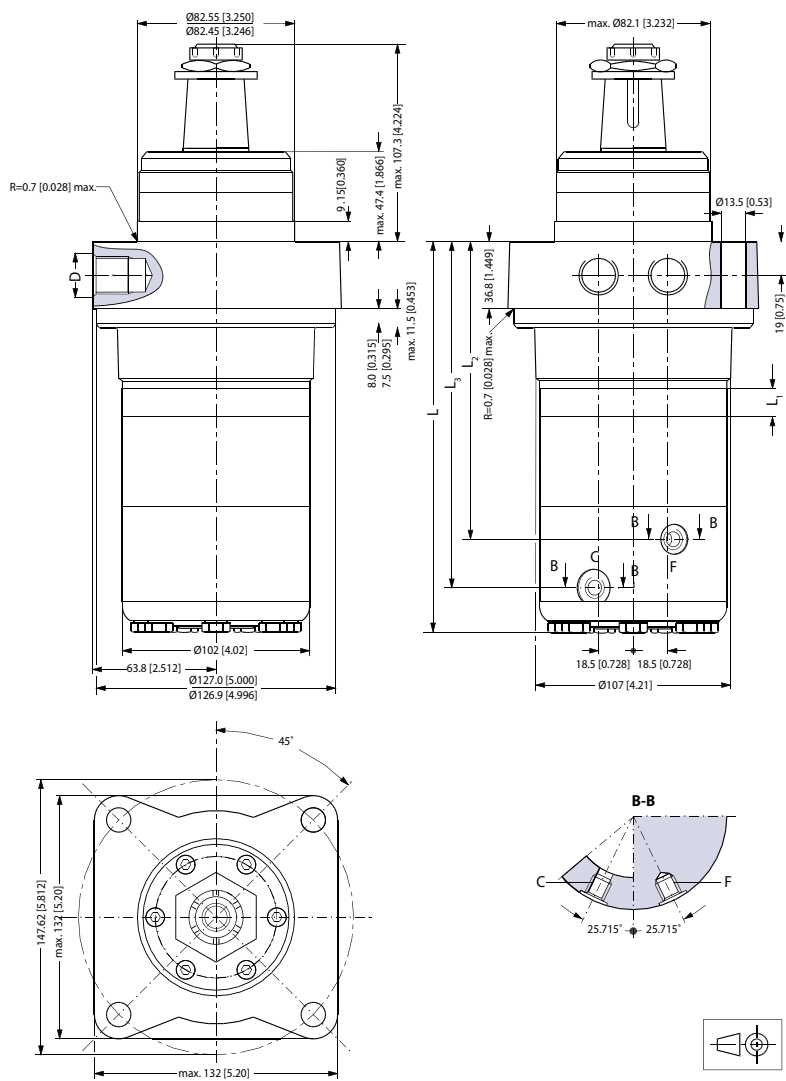
Dimensions-European Version
Dimensions
OMRW NF motor

151-1793.11

C: Drain connection

G ¼; 12 mm [0.47 in] deep

E: M8; 13 mm [0.51 in] deep

D: G ½; 15 mm [0.59 in] deep

F: Brake release connection G ¼

Type	Max. L mm [in]	L1 mm [in]
OMRW 80 NF	213.2[8.39]	14.0 [0.55]
OMRW 100 NF	216.6 [8.53]	17.4 [0.69]
OMRW 125 NF	221.0 [8.70]	21.8 [0.86]
OMRW 160 NF	227.0 [8.94]	27.8 [1.09]
OMRW 200 NF	234.0 [9.21]	34.8 [1.37]

Technical Information Orbital Motors Type OMP, OMR and OMH

Dimensions-European Version

Type	Max. L mm [in]	L1 mm [in]
OMRW 250 NF	242.7 [9.56]	43.5 [1.71]
OMRW 315 NF	254.0 [10.0]	54.8 [2.16]
OMRW 375 NF	264.2 [10.40]	65.0 [2.56]

Type	Max. L2 mm [in]	L3 mm [in]
OMRW 80 NF	159.2 [6.27]	182.7 [7.19]
OMRW 100 NF	162.6 [6.40]	186.1 [7.50]
OMRW 125 NF	167.0 [6.57]	190.5 [7.50]
OMRW 160 NF	173.0 [6.81]	196.5 [7.74]
OMRW 200 NF	180.0 [7.09]	203.5 [8.01]
OMRW 250 NF	188.7[7.43]	212.2 [8.35]
OMRW 315 NF	200.0 [7.87]	223.5 [8.80]
OMRW 375 NF	210.2 [8.28]	233.7 [9.20]

Technical Information Orbital Motors Type OMP, OMR and OMH
Version
Versions

Mounting flange	Spigot diameter (front /rear end)	Bolt circle diameter (BC)	Shaft	Port size	EU	US	Side port	End port	Flange port	Std. shaft seal	High pressure shaft seal	Drain connection	Check valve	Main type designation	
4 hole oval flange (A4-flange)	Ø 82.5 mm [3.25 in]	Ø 106.4 mm [4.20 in]	Cyl. 32 mm	G ½	*		*			*		Yes	Yes	OMH	
			Cyl. 35 mm	G ½	*		*			*		Yes	Yes	OMH	
			Cyl. 1 1/4 in	7/8 - 14 UNF		*	*				*		Yes	Yes	OMH
			Splined 1in SAE 6B	7/8 - 14 UNF		*	*				*		Yes	Yes	OMH
			Splined 1 1/4 in	G ½	*		*				*		Yes	Yes	OMH
			Splined 1 1/4 in	7/8 - 14 UNF		*	*				*		Yes	Yes	OMH
			Tapered 35 mm	G ½	*		*				*		Yes	Yes	OMH

* Version is available.

Code Numbers
Code Numbers

Code numbers	Displacement [cm ³]				
	200	250	315	400	500
151H	1002	1003	1004	1005	1006
151H	1012	1013	1014	1015	1016
151H	1042	1043	1044	1045	1046
151H	1080	1082	1083	1084	1081
151H	1022	1023	1024	1025	1026
151H	1052	1053	1054	1055	1056
151H	-	-	1034	1035	1036
	84	84	85	85	86

Ordering

Add the four digit prefix "151H" to the four digit numbers from the chart for complete code number.

Example:

151H1044 for an OMH 315 with A4 flange, cyl. 1 ¼ in shaft, port size 7/8 - 14 UNF

Orders will not be accepted without the four digit prefix.

Technical Data
Technical data for OMH with 1 in SAE 6 B splined shaft

Type			OMH	OMH	OMH	OMH	OMH
Motor size			200	250	315	400	500
Geometric displacement	cm ³		201.3	252.0	314.9	396.8	470.6
	[inch]		[12.32]	[15.42]	[19.27]	[24.28]	[28.80]
Max. speed	min ⁻¹	cont.	370	295	235	185	155
	[rpm]	int. ¹⁾	445	350	285	225	190
Max. torque	N·m [lbf·in]	cont.	340	340	340	340	340
		int. ¹⁾	510	510	540	540	520
		peak ²⁾	610	610	610	610	610
Max. output	kW [hp]	cont.	11.2	7.5	5.2	4.8	3.7
		int. ¹⁾	17.2	11.9	9.7	8.2	6.0
Max. pressure drop	bar [psi]	cont.	115	90	75	60	50
		int. ¹⁾	170	145	120	95	75
		peak ²⁾	215	175	145	110	90
Max. oil flow	l/min [US gal/min]	cont.	75	75	75	75	75
		int. ¹⁾	90	90	90	90	90
Max. starting pressure with unloaded shaft	bar [psi]		7	7	7	7	7
Min starting torque	at max. press drop cont. N·m [lbf·in]		255	270	280	290	300
	at max. press.drop int. ¹⁾ N·m [lbf·in]		390	435	450	450	450

¹⁾ Intermittent operation: the permissible values may occur for max. 10% of every minute.

²⁾ Peak load: the permissible values may occur for max. 1% of every minute.

Technical data for OMH with 32 mm and 1 1/4 in cylindrical shaft

Type			OMH	OMH	OMH	OMH	OMH
Motor size			200	250	315	400	500
Geometric displacement	cm ³		201.3	252.0	314.9	396.8	470.6
	[inch]		[12.32]	[15.42]	[19.27]	[24.28]	[28.80]
Max. speed	min ⁻¹	cont.	370	295	235	185	155
	[rpm]	int. ¹⁾	445	350	285	225	190

Technical Information Orbital Motors Type OMP, OMR and OMH
Technical Data

Type			OMH	OMH	OMH	OMH	OMH
Motor size			200	250	315	400	500
Max. torque	N•m [lbf•in]	cont.	510 [4500]	610 [5400]	590 [5220]	590 [5220]	580 [5130]
		int. ¹⁾	580 [5130]	700 [6200]	670 [5930]	700 [6200]	680 [6020]
		peak ²⁾	640 [5660]	790 [6990]	840 [7440]	840 [7440]	840 [7440]
Max. output	kW [hp]	cont.	16.0 [21.5]	16.0 [21.5]	12.5 [16.8]	10.0 [13.4]	8.5 [11.4]
		int. ¹⁾	18.5 [24.8]	18.5 [24.8]	14.0 [18.8]	12.0 [16.1]	10.0 [13.4]
Max. pressure drop	bar [psi]	cont.	175 [2540]	175 [2540]	135 [1960]	105 [1520]	85 [1230]
		int. ¹⁾	200 [2900]	200 [2900]	155 [2250]	125 [1810]	100 [1450]
		peak ²⁾	225 [3260]	225 [3260]	190 [2760]	155 [2250]	130 [1890]
Max. oil flow	l/min [US gal/min]	cont.	75 [19.8]	75 [19.8]	75 [19.8]	75 [19.8]	75 [19.8]
		int. ¹⁾	90 [23.8]	90 [23.8]	90 [23.8]	90 [23.8]	90 [23.8]
Max. starting pressure with unloaded shaft	bar [psi]		7 [100]	7 [100]	7 [100]	7 [100]	7 [100]
Min starting torque	at max. press drop cont. N•m [lbf•in]		390 [3450]	520 [4600]	510 [4510]	490 [4340]	490 [4340]
	at max. press.drop int. ¹⁾ N•m [lbf•in]		450 [3980]	590 [5220]	590 [5220]	600 [5310]	600 [5310]

¹⁾ Intermittent operation: the permissible values may occur for max. 10% of every minute.

²⁾ Peak load: the permissible values may occur for max. 1% of every minute.

Technical data for OMH with 35 mm cylindrical, 1 1/4 in splined and 35 mm tapered shaft

Type			OMH	OMH	OMH	OMH	OMH
Motor size			200	250	315	400	500
Geometric displacement	cm ³ [inch]		201.3 [12.32]	252.0 [15.42]	314.9 [19.27]	396.8 [24.28]	470.6 [28.80]
Max. speed	min ⁻¹ [rpm]	cont.	370	295	235	185	155
		int. ^{fn}	445	350	285	225	190
Max. torque	N•m [lbf•in]	cont.	510 [4500]	610 [5400]	740 [6550]	840 [7440]	820 [7260]
		int. ^{fn}	580 [5130]	700 [6200]	820 [7260]	980 [8670]	1040 [9210]
		peak ²⁾	640 [5660]	790 [6990]	980 [8670]	1090 [9650]	1170 [10360]
Max. output	kW [hp]	cont.	16.0 [21.5]	16.0 [21.5]	14.0 [18.8]	12.5 [16.8]	11.0 [14.8]
		int. ^{fn}	18.5 [24.8]	18.5 [24.8]	15.5 [20.8]	15.0 [20.1]	14.0 [18.8]

Technical Information Orbital Motors Type OMP, OMR and OMH

Technical Data

Type			OMH	OMH	OMH	OMH	OMH
Motor size			200	250	315	400	500
Max. pressure drop	bar [psi]	cont.	175 [2540]	175 [2540]	175 [2540]	155 [2250]	125 [1810]
		int. ^{fn}	200 [2900]	200 [2900]	200 [2900]	190 [2760]	160 [2320]
		peak ²⁾	225 [3260]	225 [3260]	225 [3260]	210 [3050]	180 [2610]
Max. oil flow	l/min [US gal/min]	cont.	75 [19.8]	75 [19.8]	75 [19.8]	75 [19.8]	75 [19.8]
		int. ^{fn}	90 [23.8]	90 [23.8]	90 [23.8]	90 [23.8]	90 [23.8]
Max. starting pressure with unloaded shaft	bar [psi]		7 [100]	7 [100]	7 [100]	7 [100]	7 [100]
Min starting torque	at max. press drop cont. N·m [lbf·in]		390 [3450]	520 [4600]	660 [5840]	720 [6370]	720 [6370]
	at max. press.drop int. ^{fn} N·m [lbf·in]		450 [3980]	590 [5220]	730 [6460]	880 [7790]	880 [7790]

^{fn} Intermittent operation: the permissible values may occur for max. 10% of every minute.

²⁾ Peak load: the permissible values may occur for max. 1% of every minute.

Type		Max. inlet pressure	Max. return pressure with drain line
OMH 200 - 500	bar [psi] cont	200 [2900]	175 [2540]
	bar int. ¹⁾ [psi]	225 [3260]	200 [2900]
	bar peak ²⁾ [psi]	250 [3630]	225 [3260]

¹⁾ Intermittent operation: the permissible values may occur for max. 10% of every minute.

²⁾ Peak load: the permissible values may occur for max. 1% of every minute.

Max. Permissible Shaft Seal Pressure

OMH with standard shaft seal, check valves and without use of drain connection:

The pressure on the shaft seal never exceeds the pressure in the return line

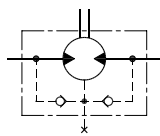

OMH with standard shaft seal, check valves and with drain connection:

The shaft seal pressure equals the pressure on the drain line.

Technical Data

Max. return pressure without drain line or max. pressure in the drain line

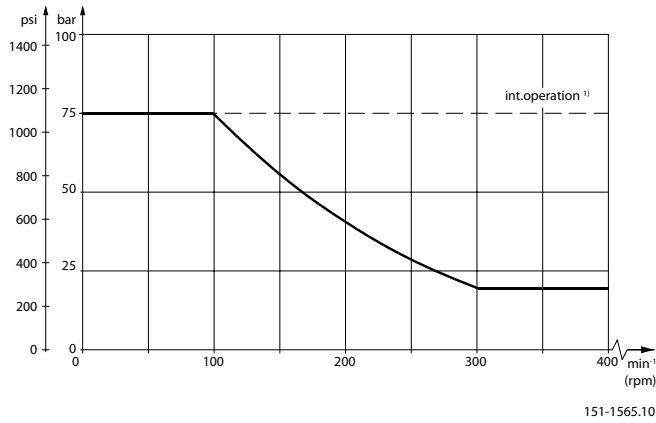

1) Intermittent operation: the permissible values may occur for max. 10% of every minute.

Pressure Drop in Motor

The curve applies to an unloaded motor shaft and an oil viscosity of 35 mm²/s [165 SUS]

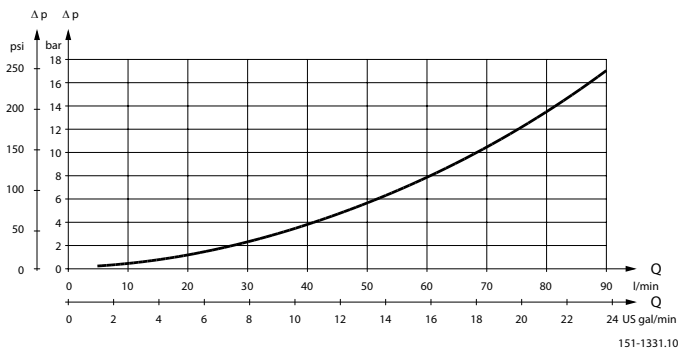

Oil Flow in Drain Line

The table shows the max. oil flow in the drain line at a return pressure less than 5-10 bar [75-150 psi].

Pressure drop bar [psi]	Viscosity		Oil flow in drain line	
	mm ² /s	[SUS]	l/min	[US gal/min]
100 [1450]	20	[100]	2.5	[0.66]
	35	[165]	1.8	[0.78]
140 [2030]	20	[100]	3.5	[0.93]
	35	[165]	2.8	[0.74]

Technical Data

Direction of Shaft Rotation

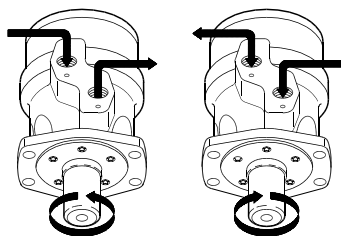

151-2107.10

Permissible Shaft Loads for OMH

The permissible shaft load (P_{rad}) is calculated from the speed (n) and the distance (l) between the point of load application and the mounting flange.

$$P_{rad} = \frac{1100}{n} \cdot \frac{250000}{103.5 + l} \quad \text{N*}; l \text{ in mm}$$

$$P_{rad} = \frac{1100}{n} \cdot \frac{2215}{4.07 + l} \quad \text{lbf*}; l \text{ in inch}$$

* $n > 200 \text{ min}^{-1}$ (rpm); $l < 60 \text{ mm}$ [2.36 in]

$n < 200 \text{ min}^{-1}$ (rpm); $\Rightarrow P_{Rmax} = 11000 \text{ N}$ [2475 lbf]

----- 1 in SAE 6B splined shaft

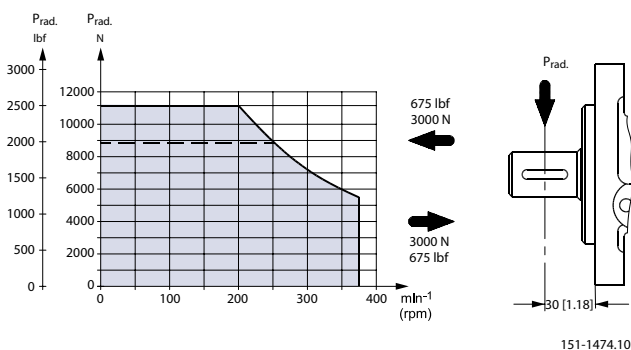

The drawing shows the permissible radial load when $l = 30 \text{ mm}$ [1.18 in].

Function Diagrams

Function Diagrams

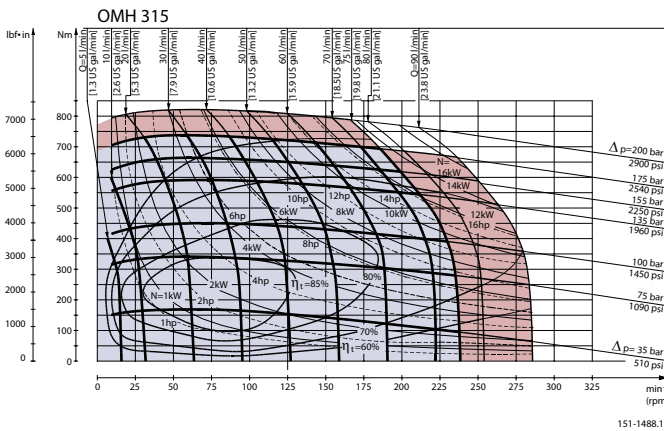
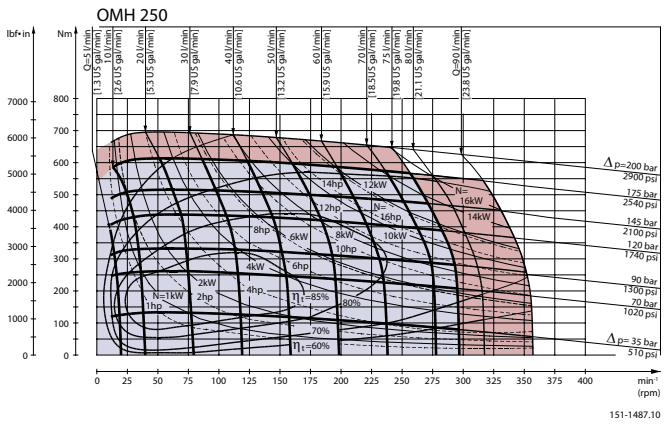
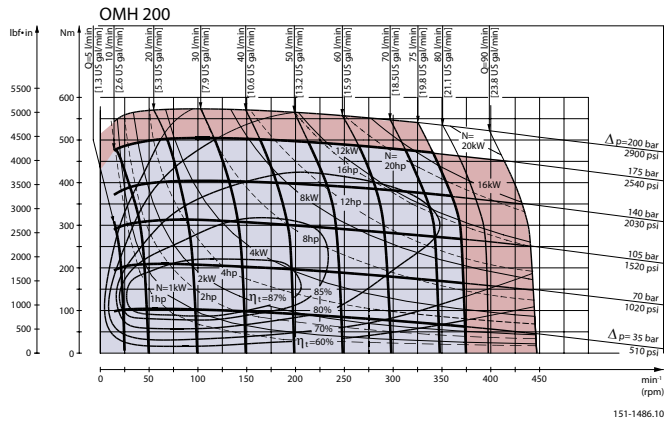

Function Diagrams

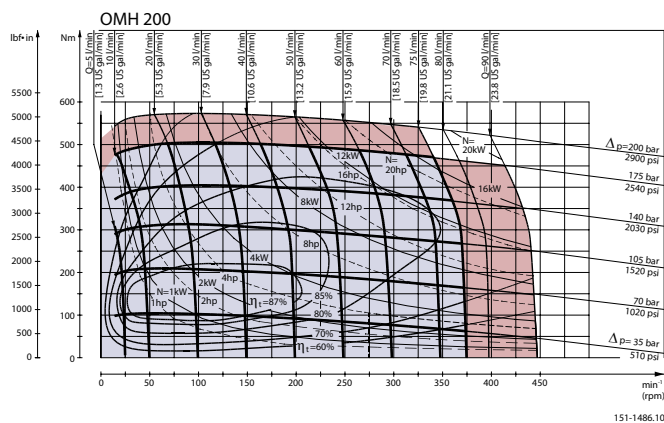
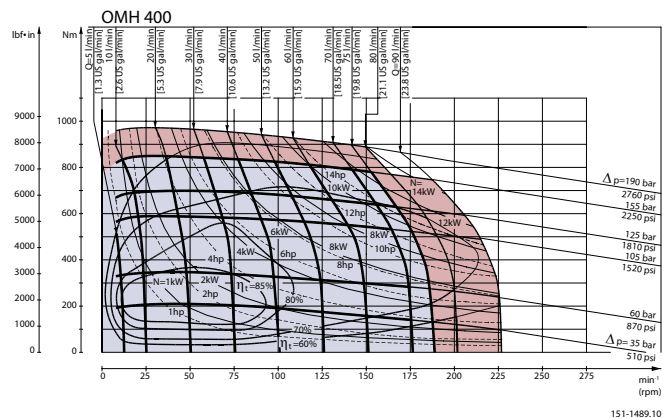

Explanation of function diagram use, basis and conditions can be found in [Speed, Torque and Output](#) on page 8.

- Continuous range
- Intermittent range (max. 10% operation every minute)

Max. permissible continuous/intermittent pressure drop for the actual shaft version can be found in [Technical data for OMH with 1 in SAE 6 B splined shaft](#) on page 83.

Intermittent pressure drop and oil flow must not occur simultaneously.

Shaft Version

Shaft Version

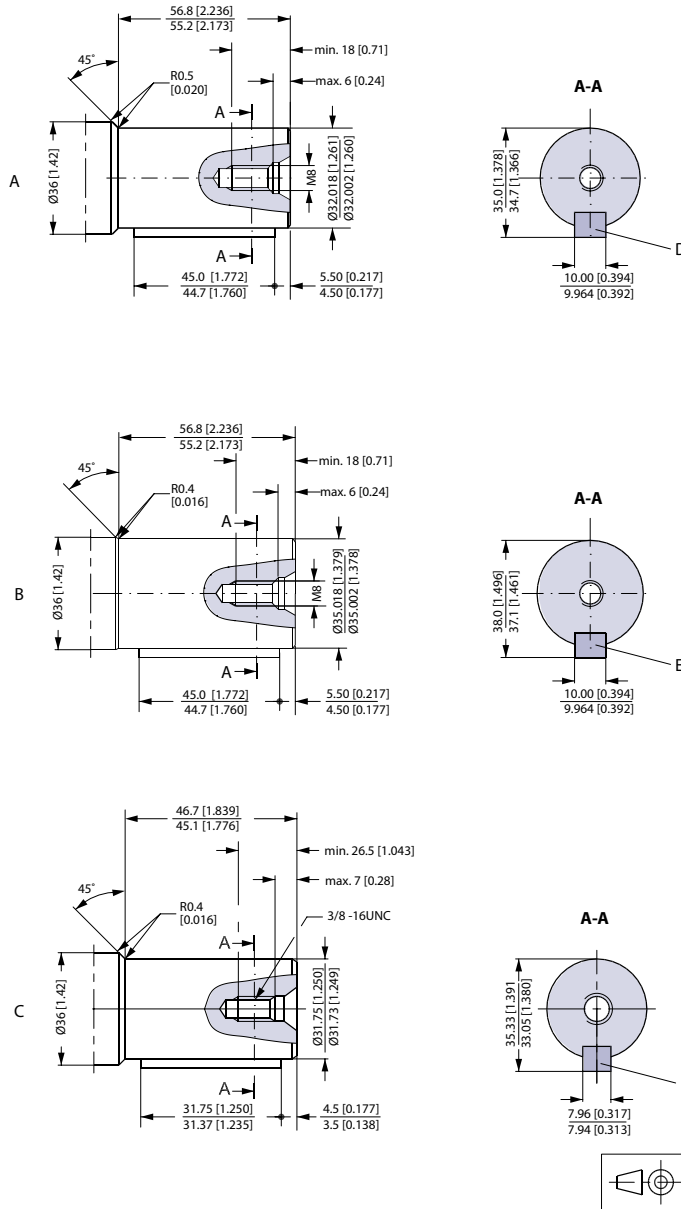

151-1852.11

A: Cylindrical shaft 32 mm

D: Parallel key
A10 × 8 × 45
DIN 6885

B: Cylindrical shaft 35 mm

E: Parallel key
A10 × 8 × 45
DIN 6885

US version

C: Cylindrical shaft 1 1/4 in

F: Parallel key
5/16 × 5/16 × 11/4 in
SAE J 744

Shaft Version

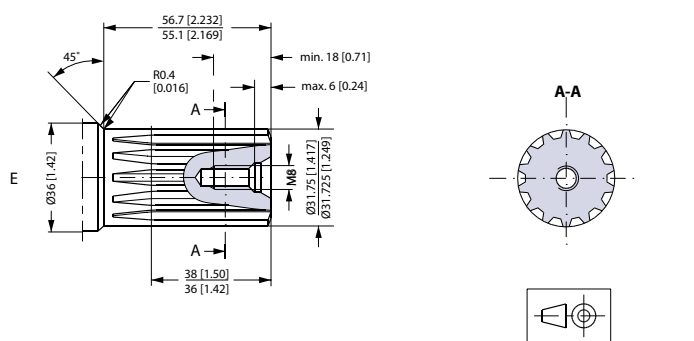
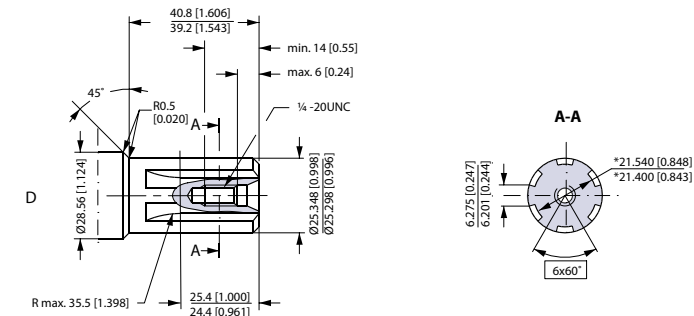

151-1853.11

D: Splined shaft
 SAE 6 B (B.S. 2059)
 Straight-sided,
 bottom fitting, deep.
 Fit 2
 Nom. size 1 in
 *Deviates from
 SAE 6 B (B.S. 2059)

E. Involute splined shaft
 ANS B92.1 - 1980 standard
 Flat root side fit
 Pitch 12/24
 Teeth 14
 Major dia. 1.25 in
 Pressure angle 30°

Shaft Version

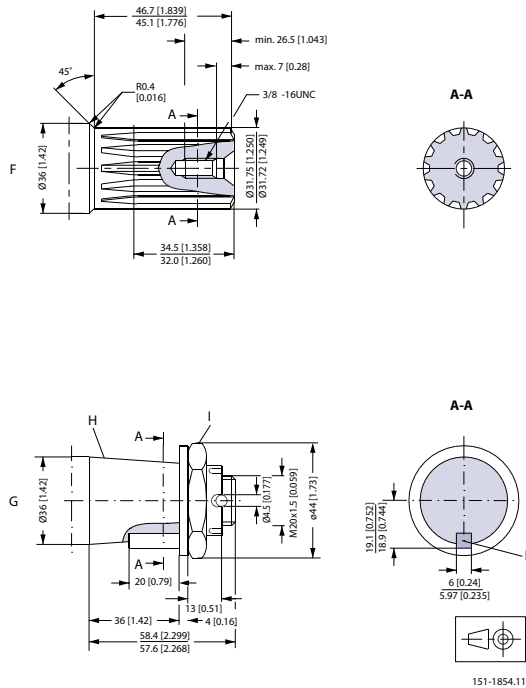

US version

- F: Involute splined shaft
- ANS B92.1 - 1970 standard
- Flat root side fit
- Pitch 12/24
- Teeth 14
- Major dia. 1.25 in
- Pressure angle 30°

- L: Parallel key
- B6 • 6 • 20
- DIN 6885

G: Tapered shaft 35 mm

H: Taper 1:10

I: DIN 937
NV 41

Tightening torque:
200 ± 10 Nm [1770 ± 85 lbf-in]

Technical Data

Port Thread Versions

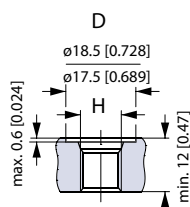
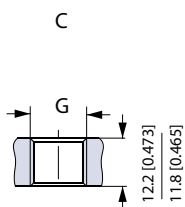
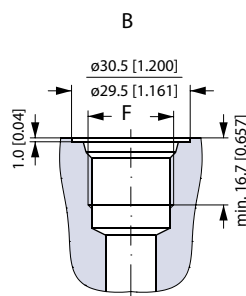
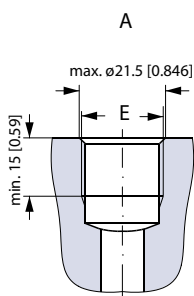

151-1858.10

A: G main ports

E: ISO 228/1 - G1/2

C: G drain port

G: ISO 228/1 - G1/4

B: UNF main ports

F: 7/8 - 14 UNF

O-ring boss port

D: UNF drain port

H: 7/16 - 20 UNF

O-ring boss port

Technical Data

Manifold Mount

European version

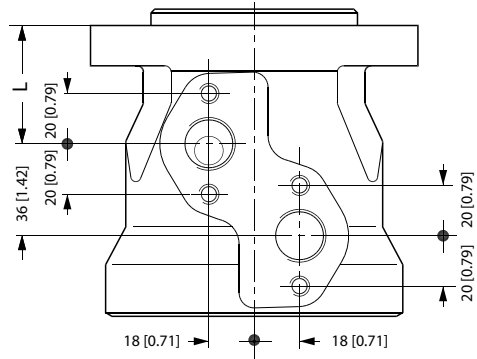

151-2135.10

L: see dimensional drawing for given OMH motor: [Dimensions-European Version](#) on page 95 and [Dimensions-US Version](#) on page 96

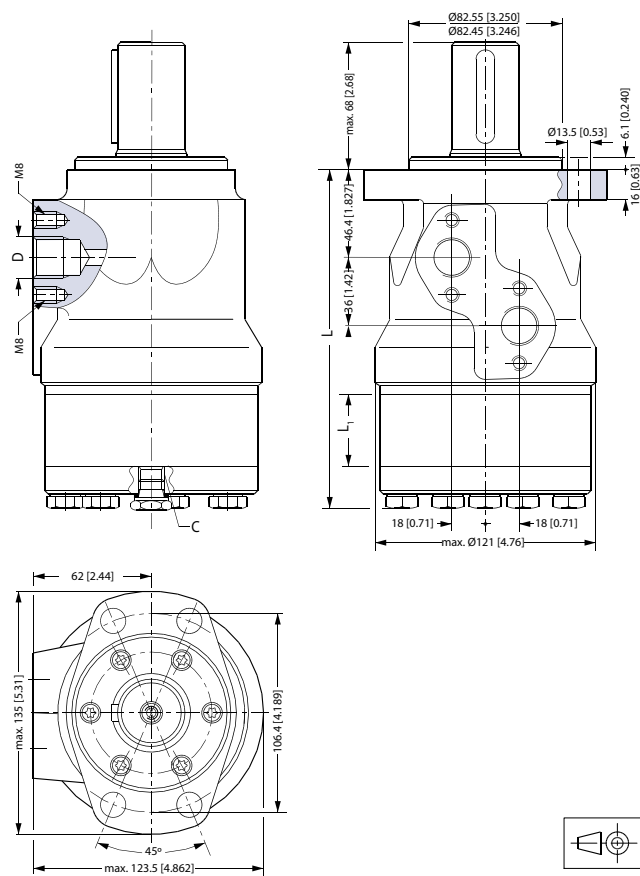
Dimensions-European Version
Dimensions
Side port version with 4 hole oval mounting flange (A4-flange).

C: Drain connection
G ¼; 12 mm [0.47 in] deep

D: G ½; 15 mm [0.59 in] deep

Type	Max. L		L1	
	mm	[in]	mm	[in]
OMH 200	171.1	[6.74]	27.8	[1.09]
OMH 250	178.1	[7.01]	34.8	[1.37]
OMH 315	186.8	[7.35]	43.5	[1.71]
OMH 400	198.1	[7.80]	54.8	[2.16]
OMH 500	208.3	[8.20]	65.0	[2.56]

Dimensions-US Version

Dimensions

Side port version with 4 hole oval mounting flange (A4 flange).

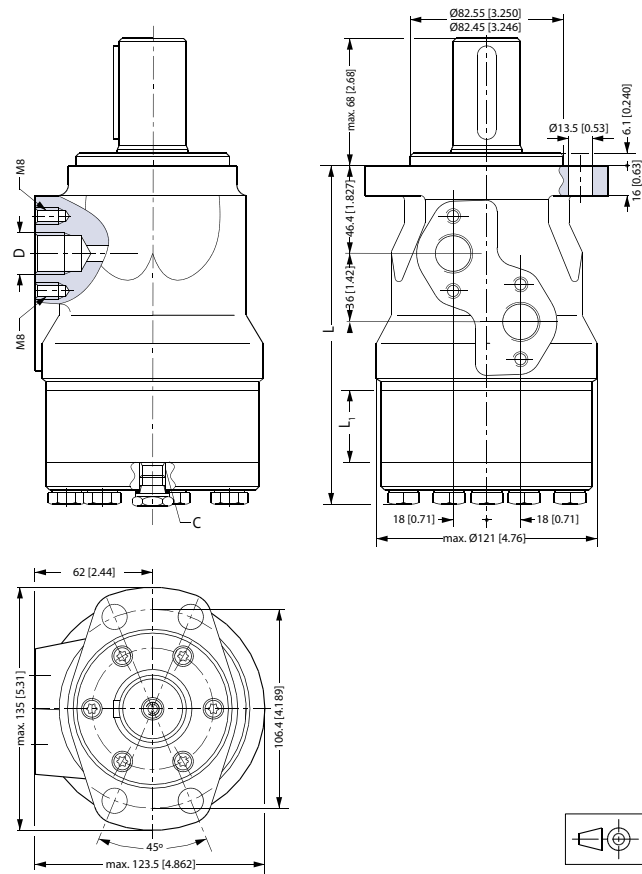

C: Drain connection
7/16 - 20 UNF;
12 mm [0.47 in] deep

D: 7/8 - 14 UNF;
15 mm [0.59 in] deep

Output shaft.max.	L2	
	mm	[in]
Splined shaft 1 in	50.5	[1.99]
Other shaft versions	58.0	[2.28]

Type	Max. L		L1	
	mm	[in]	mm	[in]
OMH 200	171.1	[6.74]	27.8	[1.09]
OMH 250	178.1	[7.01]	34.8	[1.37]
OMH 315	186.8	[7.35]	43.5	[1.71]
OMH 400	198.1	[7.80]	54.8	[2.16]
OMH 500	208.3	[8.20]	65.0	[2.56]

Technical Information Orbital Motors Type OMP, OMR and OMH

Weight of motors
Weight of Motors

Code no	Weight	
	kg	[lb]
151-0208	7.2	[15.9]
151-0242	6.9	[15.2]
151-0243	7.0	[15.4]
151-0244	7.5	[16.5]
151-0245	8.0	[17.6]
151-0246	9.0	[19.8]
151-0247	8.5	[18.7]
151-0248	6.7	[14.8]
151-0265	6.7	[14.8]
151-0266	6.9	[15.2]
151-0267	7.0	[15.4]
151-0268	7.5	[16.5]
151-0269	8.0	[17.6]
151-0270	9.0	[19.8]
151-0271	8.5	[18.7]
151-0300	5.6	[12.3]
151-0301	5.7	[12.6]
151-0302	5.9	[13.0]
151-0303	6.0	[13.2]
151-0304	6.2	[13.7]
151-0305	6.4	[14.1]
151-0306	6.6	[14.6]
151-0307	6.9	[15.2]
151-0308	7.4	[16.3]
151-0310	5.6	[12.3]
151-0311	5.7	[12.6]
151-0312	5.9	[13.0]
151-0313	6.0	[13.2]
151-0314	6.2	[13.7]
151-0315	6.4	[14.1]
151-0316	6.6	[14.6]
151-0317	6.9	[15.2]
151-0318	7.4	[16.3]
151-0319	5.6	[12.3]
151-0330	5.6	[12.3]
151-0331	5.7	[12.6]
151-0332	5.9	[13.0]
151-0333	6.0	[13.2]
151-0334	6.2	[13.7]

Weight of motors

Code no	Weight	
	kg	[lb]
151-0335	6.4	[14.1]
151-0336	6.6	[14.6]
151-0337	6.9	[15.2]
151-0338	7.4	[16.3]
151-0340	5.5	[12.1]
151-0341	5.5	[12.1]
151-0342	5.6	[12.3]
151-0400	6.7	[14.8]
151-0401	6.9	[15.2]
151-0402	7.0	[15.4]
151-0403	7.2	[15.9]
151-0404	7.5	[16.5]
151-0405	8.0	[17.6]
151-0406	8.5	[18.7]
151-0407	9.0	[19.8]
151-0408	9.5	[20.9]
151-0410	6.7	[14.8]
151-0411	6.9	[15.2]
151-0412	7.0	[15.4]
151-0413	7.2	[15.9]
151-0414	7.5	[16.5]
151-0415	8.0	[17.6]
151-0416	8.5	[18.7]
151-0417	9.0	[19.8]
151-0418	9.5	[20.9]
151-0420	6.7	[14.8]
151-0421	6.9	[15.2]
151-0422	7.0	[15.4]
151-0423	7.2	[15.9]
151-0424	7.5	[16.5]
151-0425	8.0	[17.6]
151-0426	8.5	[18.7]
151-0427	9.0	[19.8]
151-0428	9.5	[20.9]
151-0600	5.6	[12.3]
151-0601	5.7	[12.6]
151-0602	5.9	[13.0]
151-0603	6.0	[13.2]
151-0604	6.2	[13.7]
151-0605	6.4	[14.1]
151-0606	6.6	[14.6]
151-0607	6.9	[15.2]

Weight of motors

Code no	Weight	
	kg	[lb]
151-0608	7.4	[16.3]
151-0610	5.6	[12.3]
151-0611	5.7	[12.6]
151-0612	5.9	[13.0]
151-0613	6.0	[13.2]
151-0614	6.2	[13.7]
151-0615	6.4	[14.1]
151-0616	6.6	[14.6]
151-0617	6.9	[15.2]
151-0618	7.4	[16.3]
151-0622	5.9	[13.0]
151-0624	6.2	[13.7]
151-0625	6.4	[14.1]
151-0627	6.9	[15.2]
151-0630	5.6	[12.3]
151-0631	5.7	[12.6]
151-0632	5.9	[13.0]
151-0633	6.0	[13.2]
151-0634	6.2	[13.7]
151-0635	6.4	[14.1]
151-0636	6.6	[14.6]
151-0637	6.9	[15.2]
151-0638	7.4	[16.3]
151-0640	5.5	[12.1]
151-0641	5.5	[12.1]
151-0642	5.6	[12.3]
151-0646	5.9	[13.0]
151-0700	6.7	[14.8]
151-0701	6.9	[15.2]
151-0702	7.0	[15.4]
151-0703	7.2	[15.9]
151-0704	7.5	[16.5]
151-0705	8.0	[17.6]
151-0706	8.5	[18.7]
151-0707	9.0	[19.8]
151-0708	9.5	[20.9]
151-0710	6.7	[14.8]
151-0711	6.9	[15.2]
151-0712	7.0	[15.4]
151-0713	7.2	[15.9]
151-0714	7.5	[16.5]
151-0715	8.0	[17.6]

Weight of motors

Code no	Weight	
	kg	[lb]
151-0716	8.5	[18.7]
151-0717	9.0	[19.8]
151-0718	9.5	[20.9]
151-0720	6.7	[14.8]
151-0721	6.9	[15.2]
151-0722	7.0	[15.4]
151-0723	7.2	[15.9]
151-0724	7.5	[16.5]
151-0725	8.0	[17.6]
151-0726	8.5	[18.7]
151-0727	9.0	[19.8]
151-0728	9.5	[20.9]
151-1208	5.6	[12.3]
151-1209	5.7	[12.6]
151-1210	5.9	[13.0]
151-1211	6.2	[13.7]
151-1212	6.4	[14.1]
151-1213	6.6	[14.6]
151-1214	6.9	[15.2]
151-1215	7.4	[16.3]
151-1217	6.0	[13.2]
151-1231	6.7	[14.8]
151-1232	6.9	[15.2]
151-1233	7.0	[15.4]
151-1234	7.5	[16.5]
151-1235	8.0	[17.6]
151-1236	8.5	[18.7]
151-1237	9.0	[19.8]
151-1238	7.2	[15.9]
151-1243	9.5	[20.9]
151-5001	5.6	[12.3]
151-5002	5.7	[12.6]
151-5003	5.9	[13.0]
151-5004	6.0	[13.2]
151-5005	6.2	[13.7]
151-5006	6.4	[14.1]
151-5007	6.6	[14.6]
151-5008	6.9	[15.2]
151-5009	7.4	[16.3]
151-5010	5.4	[11.9]
151-5174	5.4	[11.9]
151-5191	6.1	[13.4]

Weight of motors

Code no	Weight	
	kg	[lb]
151-5192	6.2	[13.7]
151-5193	6.4	[14.1]
151-5194	6.5	[14.3]
151-5195	6.7	[14.8]
151-5196	6.9	[15.2]
151-5197	7.1	[15.7]
151-5198	7.4	[16.3]
151-5199	7.9	[17.4]
151-5211	5.5	[12.1]
151-5212	5.6	[12.3]
151-5213	5.8	[12.8]
151-5214	5.9	[13.0]
151-5215	6.1	[13.4]
151-5216	6.3	[13.9]
151-5217	6.5	[14.3]
151-5218	6.8	[15.0]
151-5219	7.3	[16.1]
151-5301	5.5	[12.1]
151-5302	5.6	[12.3]
151-5303	5.8	[12.8]
151-5304	5.9	[13.0]
151-5305	6.1	[13.4]
151-5306	6.3	[13.9]
151-5307	6.5	[14.3]
151-5308	6.8	[15.0]
151-5309	7.3	[16.1]
151-5311	5.6	[12.3]
151-5312	5.7	[12.6]
151-5313	5.9	[13.0]
151-5315	6.2	[13.7]
151-5316	6.4	[14.1]
151-5318	6.9	[15.2]
151-6000	6.7	[14.8]
151-6001	6.9	[15.2]
151-6002	7.0	[15.4]
151-6003	7.2	[15.9]
151-6004	7.5	[16.5]
151-6005	8.0	[17.6]
151-6006	8.5	[18.7]
151-6007	9.0	[19.8]
151-6008	9.5	[20.9]
151-6010	6.7	[14.8]

Weight of motors

Code no	Weight	
	kg	[lb]
151-6011	6.9	[15.2]
151-6012	7.0	[15.4]
151-6013	7.2	[15.9]
151-6014	7.5	[16.5]
151-6015	8.0	[17.6]
151-6016	8.5	[18.7]
151-6017	9.0	[19.8]
151-6018	9.5	[20.9]
151-6110	6.7	[14.8]
151-6111	6.9	[15.2]
151-6112	7.0	[15.4]
151-6113	7.2	[15.9]
151-6114	7.5	[16.5]
151-6115	8.0	[17.6]
151-6116	8.5	[18.7]
151-6117	9.0	[19.8]
151-6118	9.5	[20.9]
151-6190	7.3	[16.1]
151-6191	7.5	[16.5]
151-6192	7.6	[16.8]
151-6193	7.8	[17.2]
151-6194	8.1	[17.9]
151-6195	8.6	[19.0]
151-6196	9.1	[20.1]
151-6197	9.6	[21.2]
151-6198	10.1	[22.3]
151-6210	6.7	[14.8]
151-6211	6.9	[15.2]
151-6212	7.0	[15.4]
151-6213	7.2	[15.9]
151-6214	7.5	[16.5]
151-6215	8.0	[17.6]
151-6216	8.5	[18.7]
151-6217	9.0	[19.8]
151-6218	9.5	[20.9]
151-6294	9.5	[20.9]
151-6295	7.2	[15.9]
151-6296	9.5	[20.9]
151-6300	9.0	[19.8]
151-6301	9.4	[20.7]
151-6302	9.5	[20.9]
151-6303	9.7	[21.4]

Weight of motors

Code no	Weight	
	kg	[lb]
151-6304	10.0	[22.1]
151-6305	10.5	[23.1]
151-6306	11.0	[24.3]
151-6307	11.5	[25.4]
151-6308	12.0	[26.5]
151-6380	6.7	[14.8]
151-6381	6.9	[15.2]
151-6383	7.2	[15.9]
151-6384	7.5	[16.5]
151-6385	8.0	[17.6]
151-6386	8.5	[18.7]
151-6387	9.0	[19.8]
151-6388	9.5	[20.9]
151-6430	9.0	[19.8]
151-6431	9.4	[20.7]
151-6432	9.5	[20.9]
151-6433	9.7	[21.4]
151-6434	10.0	[22.1]
151-6435	10.5	[23.1]
151-6436	11.0	[24.3]
151-6437	11.5	[25.4]
151-6438	12.0	[26.5]
151-6442	14.5	[32.0]
151-6443	14.7	[32.4]
151-6444	15.0	[33.1]
151-6445	15.5	[34.2]
151-6461	11.5	[25.4]
151-6462	12.0	[26.5]
151-6463	12.0	[26.5]
151-6464	12.5	[27.6]
151-6465	12.5	[27.6]
151-6466	13.0	[28.7]
151-6467	13.5	[29.8]
151-6468	14.0	[30.9]
151-6471	11.5	[25.4]
151-6472	12.0	[26.5]
151-6473	12.0	[26.5]
151-6474	12.5	[27.6]
151-6475	12.5	[27.6]
151-6476	13.0	[28.7]
151-6477	13.5	[29.8]
151-6478	14.0	[30.9]

Weight of motors

Code no	Weight	
	kg	[lb]
151-7021	5.0	[11.0]
151-7022	5.1	[11.2]
151-7023	5.3	[11.7]
151-7024	5.4	[11.9]
151-7025	5.6	[12.3]
151-7026	5.8	[12.8]
151-7027	6.0	[13.2]
151-7028	6.3	[13.9]
151-7029	6.8	[15.0]
151-7041	5.6	[12.3]
151-7042	5.7	[12.6]
151-7043	5.9	[13.0]
151-7044	5.4	[11.9]
151-7045	6.2	[13.7]
151-7046	6.4	[14.1]
151-7047	6.6	[14.6]
151-7048	6.9	[15.2]
151-7049	7.4	[16.3]
151-7061	5.0	[11.0]
151-7062	5.1	[11.2]
151-7063	5.3	[11.7]
151-7065	5.6	[12.3]
151-7066	5.8	[12.8]
151-7067	6.0	[13.2]
151-7068	6.3	[13.9]
151-7069	6.8	[15.0]
151-7080	5.4	[12.0]
151-7081	5.4	[12.0]
151-7082	5.6	[12.3]
151-7101	5.5	[12.1]
151-7102	5.6	[12.3]
151-7103	5.8	[12.8]
151-7104	5.9	[13.0]
151-7105	6.1	[13.4]
151-7106	6.3	[13.9]
151-7107	6.5	[14.3]
151-7108	6.8	[15.0]
151-7109	7.3	[16.1]
151-7240	6.7	[14.8]
151-7241	6.9	[15.2]
151-7242	7.0	[15.4]
151-7243	7.2	[15.9]

Weight of motors

Code no	Weight	
	kg	[lb]
151-7244	7.5	[16.5]
151-7245	8.0	[17.6]
151-7246	8.5	[18.7]
151-7247	9.0	[19.8]
151-7248	9.5	[20.9]
151-7250	6.7	[14.8]
151-7251	6.9	[15.2]
151-7252	7.0	[15.4]
151-7253	7.2	[15.9]
151-7254	7.5	[16.5]
151-7255	8.0	[17.6]
151-7256	8.5	[18.7]
151-7257	9.0	[19.8]
151-7258	9.5	[20.9]
151-7260	6.1	[13.4]
151-7261	6.3	[13.9]
151-7262	6.4	[14.1]
151-7263	6.6	[14.6]
151-7264	6.9	[15.2]
151-7265	7.4	[16.3]
151-7266	7.9	[17.4]
151-7267	8.4	[18.5]
151-7269	8.9	[19.6]
151H1002	10.5	[23.1]
151H1003	11.0	[24.3]
151H1004	11.5	[25.4]
151H1005	12.3	[27.1]
151H1006	13.0	[28.7]
151H1012	10.5	[23.1]
151H1013	11.0	[24.3]
151H1014	11.5	[25.4]
151H1015	12.3	[27.1]
151H1016	13.0	[28.7]
151H1022	10.5	[23.1]
151H1023	11.0	[24.3]
151H1024	11.5	[25.4]
151H1025	12.3	[27.1]
151H1026	13.0	[28.7]
151H1034	11.5	[25.4]
151H1035	12.3	[27.1]
151H1036	13.0	[28.7]
151H1042	10.5	[23.1]

Weight of motors

Code no	Weight	
	kg	[lb]
151H1043	11.0	[24.3]
151H1044	11.5	[25.4]
151H1045	12.3	[27.1]
151H1046	13.0	[28.7]
151H1052	10.5	[23.1]
151H1053	11.0	[24.3]
151H1054	11.5	[25.4]
151H1055	12.3	[27.1]
151H1056	13.0	[28.7]
151H1080	10.5	[23.1]
151H1081	13.0	[28.7]
151H1082	11.0	[24.3]
151H1083	11.5	[25.4]
151H1084	12.3	[27.1]



Products we offer:

- Bent Axis Motors
- Closed Circuit Axial Piston Pumps and Motors
- Displays
- Electrohydraulic Power Steering
- Electrohydraulics
- Hydraulic Power Steering
- Integrated Systems
- Joysticks and Control Handles
- Microcontrollers and Software
- Open Circuit Axial Piston Pumps
- Orbital Motors
- PLUS+1® GUIDE
- Proportional Valves
- Sensors
- Steering
- Transit Mixer Drives

Danfoss Power Solutions is a global manufacturer and supplier of high-quality hydraulic and electronic components. We specialize in providing state-of-the-art technology and solutions that excel in the harsh operating conditions of the mobile off-highway market. Building on our extensive applications expertise, we work closely with our customers to ensure exceptional performance for a broad range of off-highway vehicles.

We help OEMs around the world speed up system development, reduce costs and bring vehicles to market faster.

Danfoss – Your Strongest Partner in Mobile Hydraulics.

Go to www.powersolutions.danfoss.com for further product information.

Wherever off-highway vehicles are at work, so is Danfoss. We offer expert worldwide support for our customers, ensuring the best possible solutions for outstanding performance. And with an extensive network of Global Service Partners, we also provide comprehensive global service for all of our components.

Please contact the Danfoss Power Solution representative nearest you.

Comatrol

www.comatrol.com

Schwarzmueller-Inverter

www.schwarzmueller-inverter.com

Turolla

www.turollaocg.com

Valmova

www.valmova.com

Hydro-Gear

www.hydro-gear.com

Daikin-Sauer-Danfoss

www.daikin-sauer-danfoss.com

Local address:

Danfoss Power Solutions (US) Company
2800 East 13th Street
Ames, IA 50010, USA
Phone: +1 515 239 6000

Danfoss Power Solutions GmbH & Co. OHG
Krokamp 35
D-24539 Neumünster, Germany
Phone: +49 4321 871 0

Danfoss Power Solutions ApS
Nordborgvej 81
DK-6430 Nordborg, Denmark
Phone: +45 7488 2222

Danfoss Power Solutions (Shanghai) Co., Ltd.
Building #22, No. 1000 Jin Hai Rd
Jin Qiao, Pudong New District
Shanghai, China 201206
Phone: +86 21 3418 5200

Danfoss can accept no responsibility for possible errors in catalogues, brochures and other printed material. Danfoss reserves the right to alter its products without notice. This also applies to products already on order provided that such alterations can be made without changes being necessary in specifications already agreed. All trademarks in this material are property of the respective companies. Danfoss and the Danfoss logotype are trademarks of Danfoss A/S. All rights reserved.