

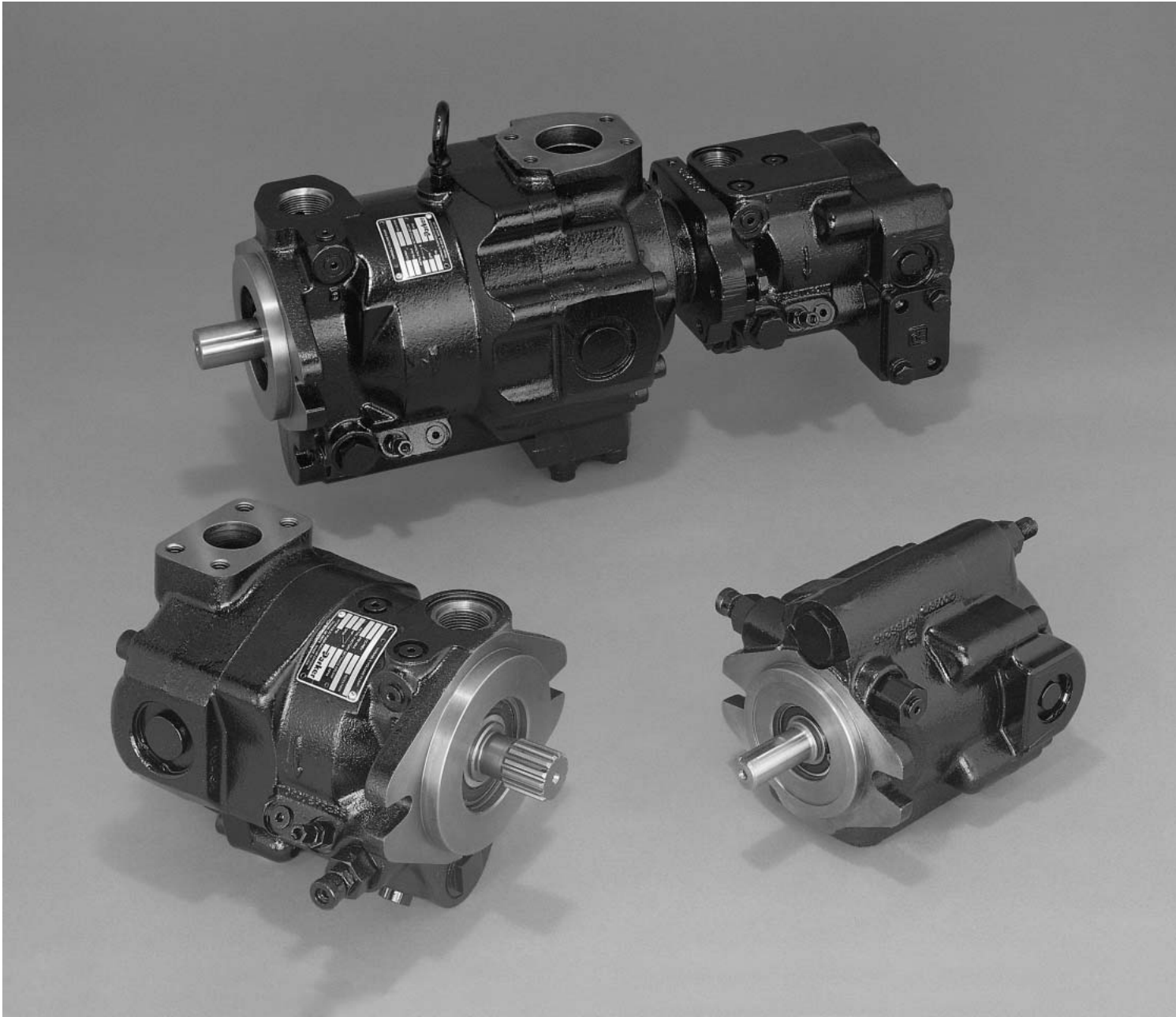

# **Series PAVC Variable Displacement Piston Pumps**

*Catalog HY28-2661-CD/US*

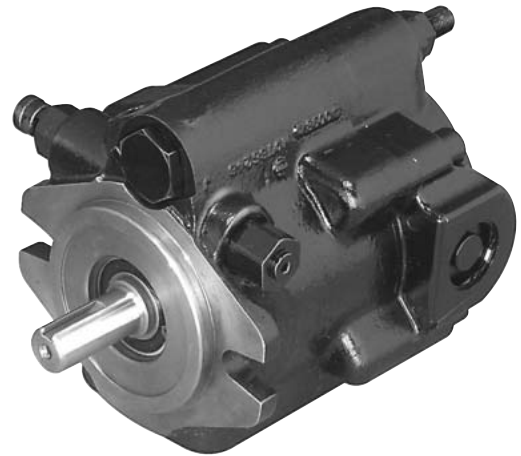

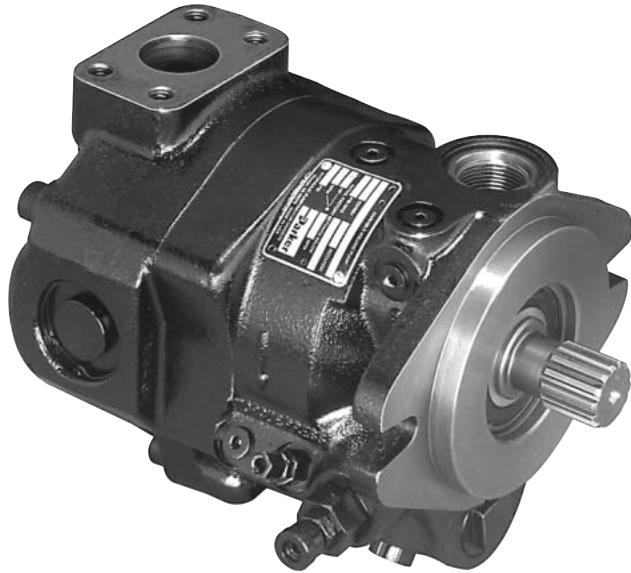

**Quick Reference Data Chart**

Pump Model	Displacement CM <sup>3</sup> /REV (IN <sup>3</sup> /REV)	Pump Delivery @ 21 bar (300 PSI) in LPM (GPM)		*Approx. Noise Levels dB(A) @ Full Flow 1800 RPM (1200 RPM)				Input Power At 1800 RPM, Maximum Displacement & 207 bar (3000 PSI)	Operating Speed RPM (Maximum)	Pressure bar (PSI) Continuous (Maximum)
		1200 RPM	1800 RPM	34 bar	69 bar	138 bar	207 bar			
				(500 PSI)	(1000 PSI)	(2000 PSI)	(3000 PSI)			
PAVC33	33 (2.0)	39.4 (10.4)	59.0 (15.6)	75 (69)	76 (72)	78 (75)	79 (77)	21.3 kw (28.5 hp)	3000	207 (3000)
PAVC38	38 (2.3)	45.0 (11.9)	67.8 (17.9)	75 (69)	76 (72)	78 (75)	79 (77)	24.6 kw (33.0 hp)	3000	207 (3000)
PAVC65	65 (4.0)	78.7 (20.8)	118.1 (31.2)	77 (75)	78 (76)	80 (78)	81 (79)	43.1 kw (57.8 hp)	3000	207 (3000)
PAVC100	100 (6.1)	119.6 (31.6)	179.8 (47.5)	83 (77)	82 (78)	82 (79)	85 (80)	71.2 kw (95.5 hp)	2600	207 (3000)

\* Since many variables such as mounting, tank style, plant layout, etc., effect noise levels, it cannot be assumed that the above readings will be equal to those in the field. The above values are for guidance in selecting the proper pump. Noise levels are A-weighted, mean sound pressure levels at 1 meter from the pump, measured and recorded in accordance with applicable ISO and NFPA standards.

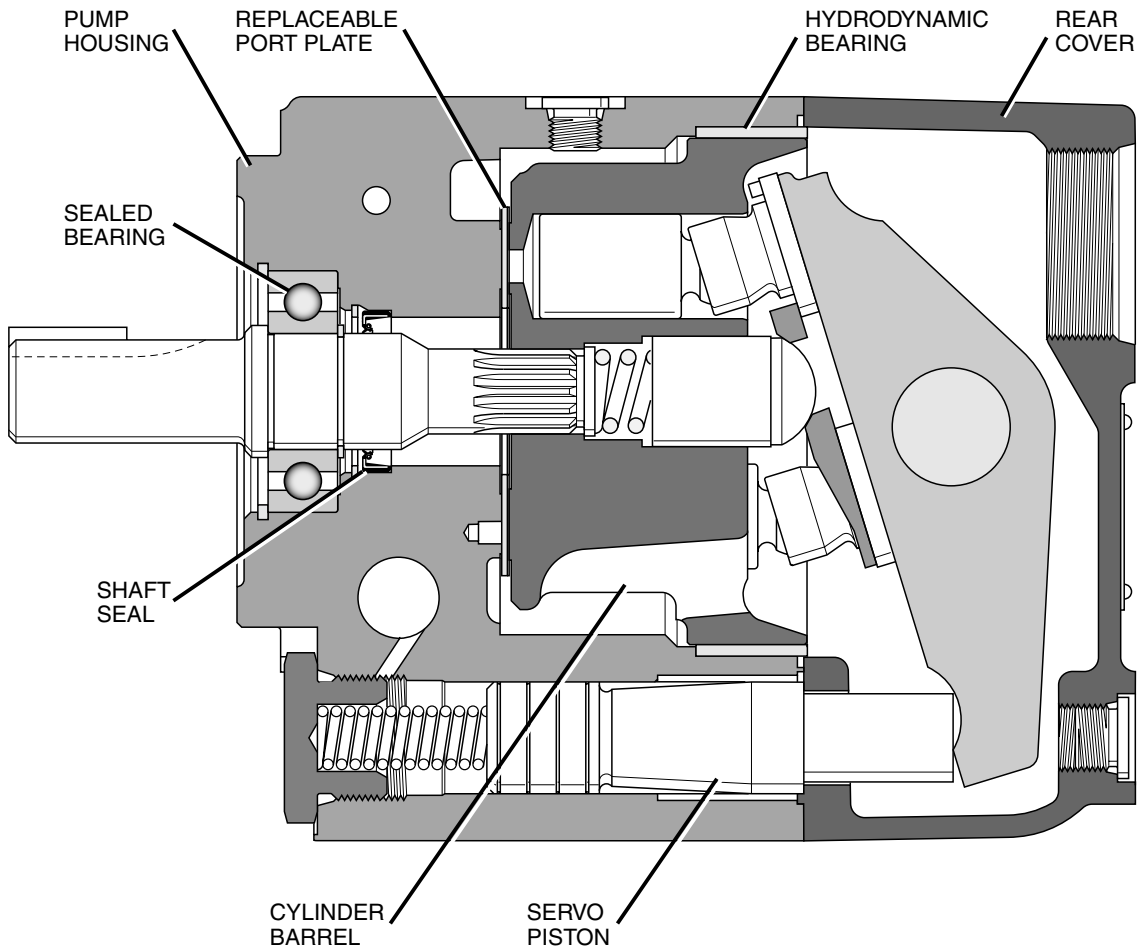

**Features**

- High Strength Cast-Iron Housing
- Built-In Supercharger Ensures High Speed Capability - 3000 RPM (2600 RPM PAVC100)
- Sealed Shaft Bearing
- Two Piece Design for Ease of Service
- Cartridge Type Controls - Field Changeable
- Replaceable Bronze Clad Port Plate
- Airbleed Standard for Quick Priming
- Hydrodynamic Cylinder Barrel Bearing
- Thru-Shaft (PAVC100 Only)
- Full Pressure Rating on Most Water Glycol Fluids
- Pump Case and Shaft Seal are Subjected to Inlet Pressure Only
- Filter and/or Cool Drain Line  
7 bar (100 PSI) Maximum

**Controls**

- Pressure Compensation
- Load Sensing
- Power (Torque) Limiting
- Power and Load Sensing
- Remote Pressure Compensation
- Adjustable Maximum Volume Stop
- Electrohydraulic Flow and Pressure
- Low Pressure Standby

**General Description**

All control is achieved by the proper positioning of the swash plate. This is achieved by a servo piston acting on one end of the swash plate working against the combined effect of the off-setting forces of the pistons and centering spring on the other end. The control spool acts as a metering valve which varies the pressure behind the servo piston.

As shown in Figure 1, the amount of flow produced by the Parker Piston Pump is dependent upon the length of stroke of the pumping pistons. This length of stroke, in turn, is determined by the position of the swash plate. Maximum flow is achieved at an angle of 17°.

The rotating piston barrel, driven by the prime mover, moves the pistons in a circular path and the piston slippers are supported hydrostatically against the face of

the swash plate. When the swash plate is in a vertical position, perpendicular to the centerline of the piston barrel, there is no piston stroke and consequently no fluid displacement. When the swash plate is positioned at an angle, the pistons are forced in and out of the barrel and fluid displacement takes place. The greater the angle of the swash plate, the greater the piston stroke.

The centerline of the pumping piston assembly is offset from the centerline of the swash plate. Therefore, as shown on the accompanying Figure 1A, the pistons' effective summation force tends to destroke the swash plate to a vertical (neutral) position. This destroking force is balanced as the swash plate is angled by the force of the servo piston.

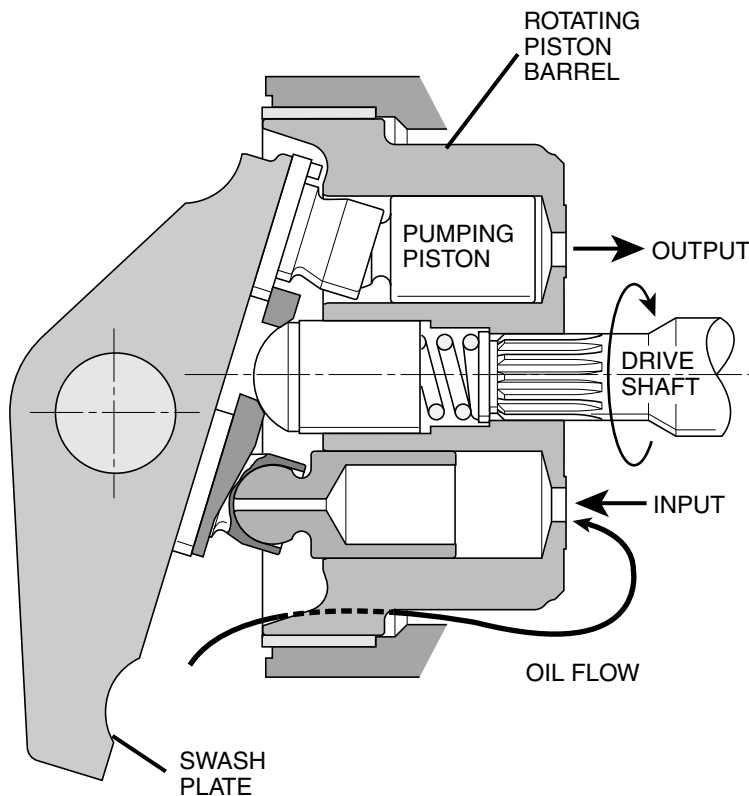

**FIGURE 1. Pumping Action**

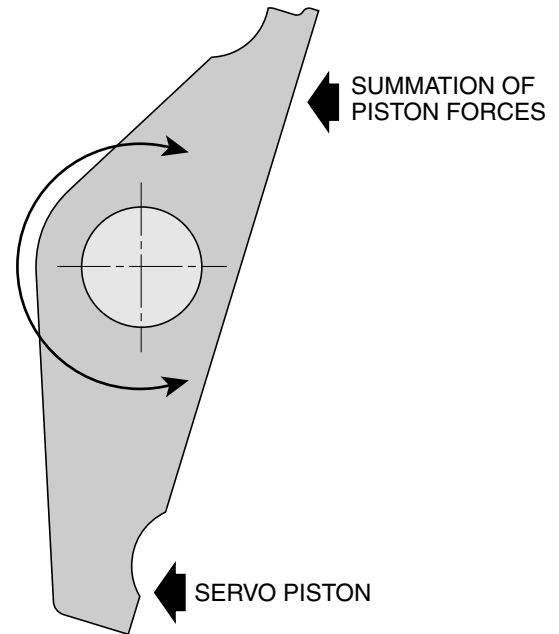

**FIGURE 1A.**

**Pressure Compensated Control**

Swash plate angle controls the output flow of the pump. Swash plate angle is controlled by the force generated against the swash plate by the pumping pistons and by the force of the servo piston. The force of the servo piston is greater than the force of the pumping pistons when both are at the same pressure.

By means of internal porting, pressure is connected from the output port to the servo piston via orifice (E), and to the control spool via passage (D). Also pressure is applied to the control spool chamber thru orifice (F). As long as the pressures at both ends of the control spool remain equal, the spool will remain offset upward, due to the added force of the spring.

When pressure reaches the setting of the compensator control, the dart leaves its seat causing the pressure in the spool chamber to be reduced. The spool now moves downward causing pressure in the servo piston cavity to vent via port "A". The reduced pressure at the servo piston allows the servo piston to move to the right. This movement reduces the angle of the swash plate and thereby reduces the pumps output flow.

As pump pressure on the control spool drops below pressure and spring force in the spool chamber, the control spool moves upward to maintain an equilibrium on both sides of the spool. If pump pressure falls below

compensator control setting, the control spool moves up, bringing the pump to maximum displacement.

**ΔP Adjustment of PAVC Pumps**  
**PROCEDURE:**

a. Standard Pressure Compensated Pump

Pumps are shipped from factory with a differential pressure of approximately 150 PSI (10 bar) on PAVC 33/38/65, PAVC 100 is 300 PSI (21 bar) at 50% of maximum swash angle. Differential pressure will not normally change through the life of the pump. If this control has been tampered with, a close **approximation** of the correct setting can be made as follows:

Dead head the pump (no flow) with a 0-207 bar (0-3000 PSI) gauge in the **OUTLET** (not the low signal "B" port), back the pressure compensator adjustment out (full counterclockwise).

The gauge should read between 22-26 bar (325-375 PSI) PAVC 33, 38 & 65, 34-40 bar (500-575 PSI) PAVC 100. If the gauge reads different than this, turn the differential adjustment knob (Differential Option 4) or add/remove shims (Omit Option) until correct pressure figure is reached.

**CONTROL OPTION - 'OMIT'**

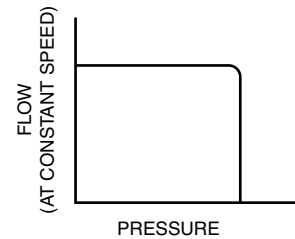
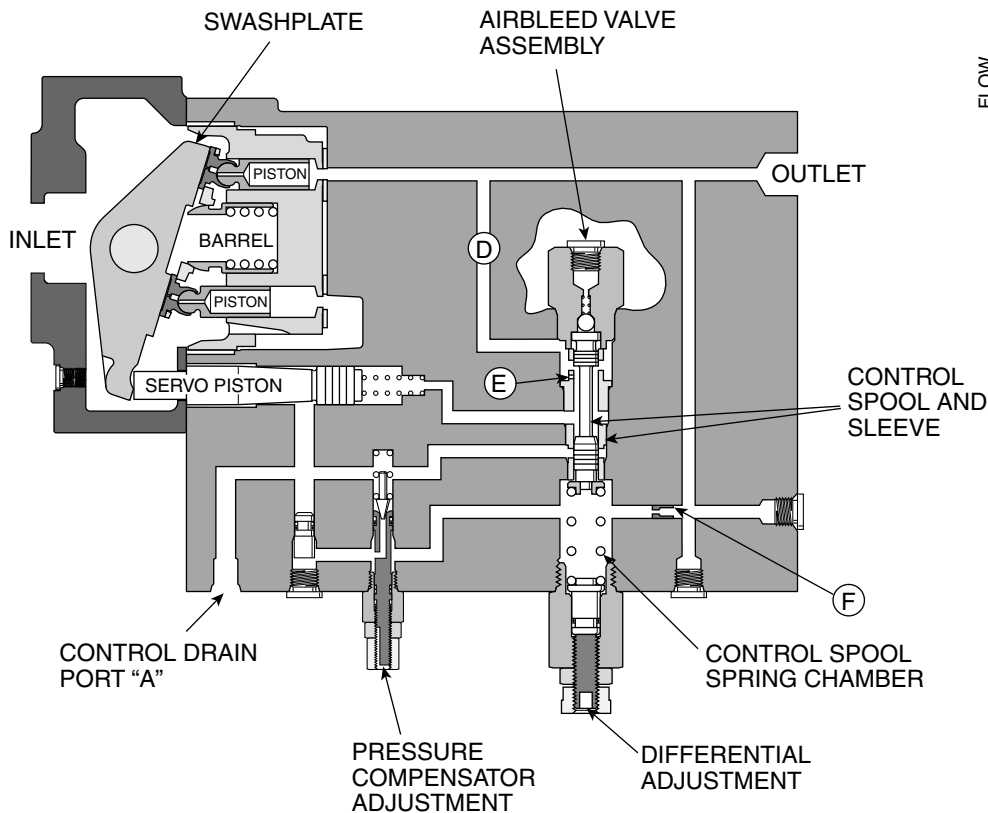



## Remote Pressure Control

### Control Type (M)

Remote control of the PAVC output pressure can be achieved by controlling the pressure in the low signal "B" port when the pump is set up for Control Type (M). A manual, hydraulically piloted, electrical or electro-proportionally controlled pressure control device is installed in the line from the low signal "B" port to tank. The pump will then maintain pressure approximately equal to the pressure in the "B" port plus the pump differential setting.

### Low Pressure Standby

This option can be used as an alternative to the load sensing option (A) to achieve low pressure standby. Minimum standby pressure is somewhat higher than that achieved using option (A). In the compensating mode there is approximately 1.1 LPM (.3 GPM) flow from the low signal "B" port in addition to 3.4 LPM (.9 GPM) flow from the control drain port "A".

### Multiple Pressure Standby

If the pressure level in the low signal "B" port is limited by a relief valve, as the desired pump outlet pressure is reached, the relief valve in the "B" port will allow the pump to standby at a preset pressure. Adding to this concept, multiple, remotely piloted relief valves plumbed in parallel in the "B" port line can yield multiple, sequential pressure settings.

### Electrohydraulic Pressure & Flow Control

A proportional pressure control valve can be used in place of relief valves to give variable pressure control proportional to an electrical input signal to the valve. By combining this arrangement with a swash plate position sensing device, amplifier, and logic circuit, servo control of pressure and/or flow is achieved. **NOTE:** In most systems, a load equivalent to the minimum operating pressure of the pump cannot be guaranteed. Because of this, a sequence valve is required in the discharge line to maintain servo flow control. Please refer to ordering information section for servo components.

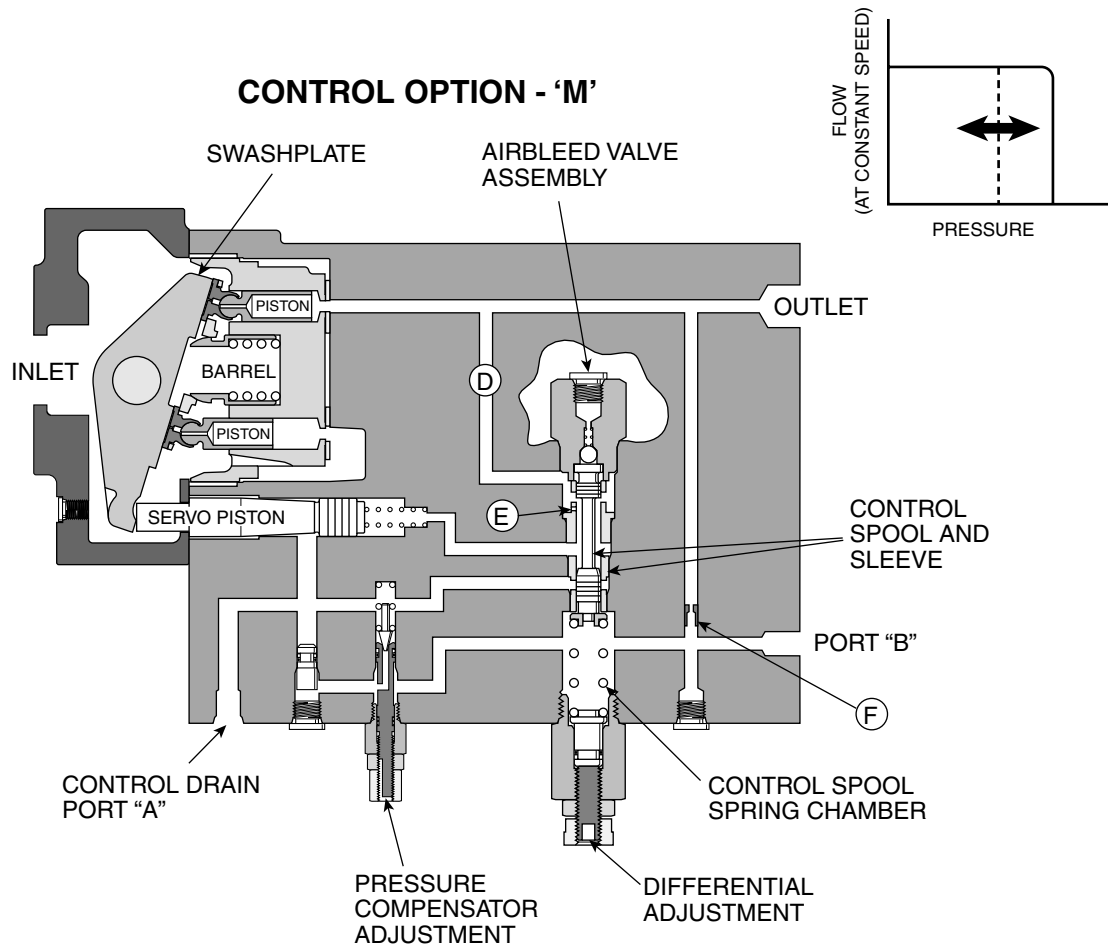

**Pressure & Flow Control (Load Sensing)  
 Control Type (A)**

Flow control is achieved by placing an orifice (fixed or adjustable) in the pump outlet port. The pressure drop ( $\Delta P$ ) across this flow control is the governing signal that controls the pump's output, as explained below.

Whenever the pressure drop at the flow control increases (indicating an increase in output flow), the pump attempts to compensate by decreasing the output flow. It does this by sensing the lower pressure on the downstream side of the flow control via line (C), which is balanced against the pump pressure via passage (D), on the control spool. The control spool is forced down against the control spool spring by differential pressure. This vents the servo piston cavity, destroking the pump to a point where the set pressure drop across the orifice is maintained and the flow is obtained.

The converse of this is also true whenever the pressure drop decreases (indicating a decrease in output flow). In this case, the control spool is forced up. This increases pump displacement in an attempt to maintain the predetermined pressure drop or constant flow.

It should be noted that the pump is still pressure compensated and destrokes at the selected pressure setting. The pressure compensator control will override the flow control whenever the pressure compensator control setting is reached.

**Low Pressure Standby**

This arrangement can also be used to provide low pressure standby by venting the "B" port through a simple on/off valve suitable for flows of 3.8-7.6 LPM (1-2 GPM). When flow or pressure is required, this valve is closed allowing system pressure to build behind the control spool and bringing the pump on-stroke.

**Load Sensing**

If, instead of measuring the pressure drop across the orifice in the pump outlet port, it is measured downstream of a directional control valve, a constant pressure drop will be maintained across the valve spool. This results in a constant flow for any given opening of the directional control valve regardless of the work load downstream or the operating speed of the pump.

The pump "senses" the amount of pressure necessary to move the load and adjusts output flow to match the valve opening selected and pressure to overcome the load plus the preset  $\Delta P$  across the valve spool.

The benefits of this arrangement are that excellent, repeatable flow characteristics are achieved, and considerable energy savings are realized while metering, compared to using a straight pressure compensated system.

**CONTROL OPTION - 'A'**

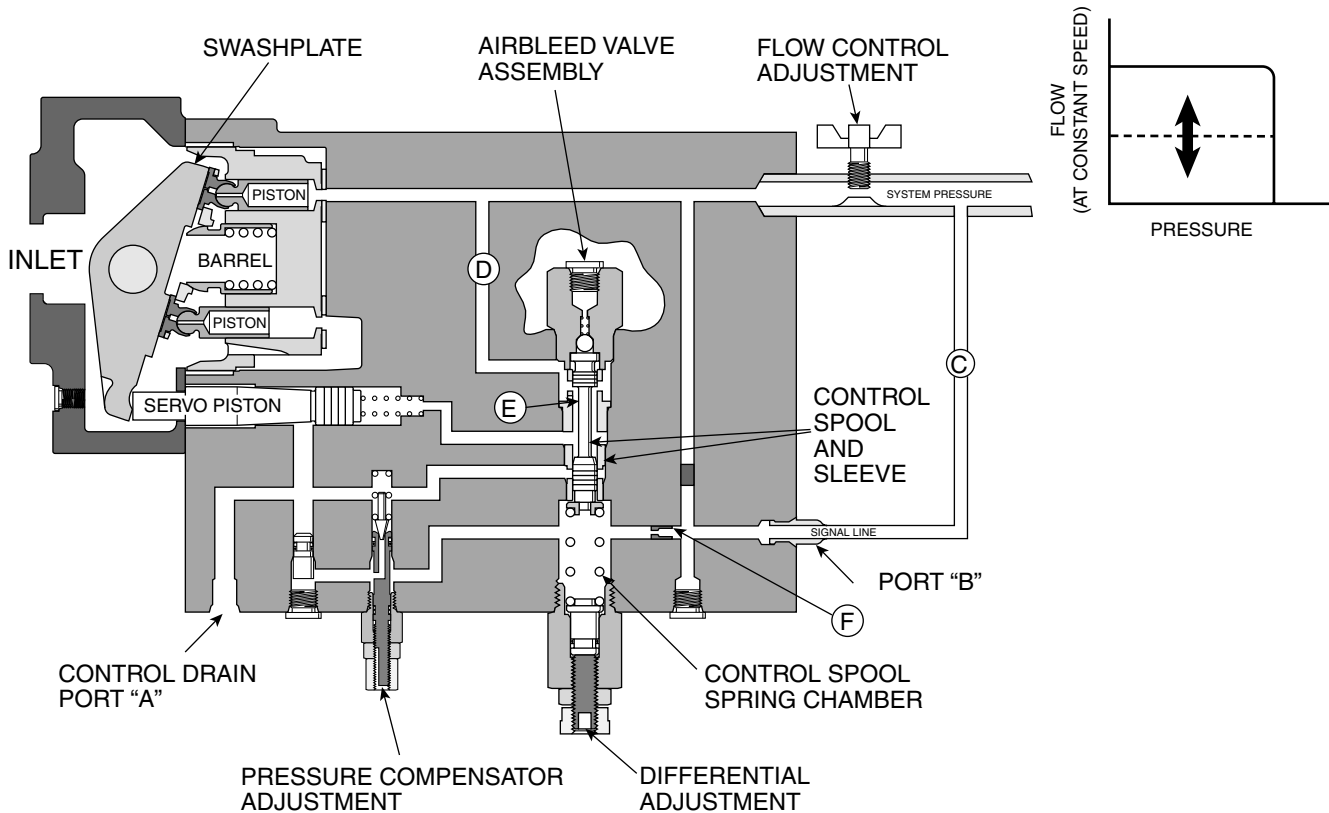

**Pressure & Power (Torque) Control  
 Control Type (H)**

The power control is sensitive to the position of the servo piston. When the servo piston is to the right, the swash plate causes low flow and the power control piston develops maximum spring pressure on its companion poppet (mechanical feedback). When the servo piston is left and the flow is high, the power control piston reduces spring pressure on the poppet. This allows it to open under less pressure in the control spool chamber, thereby venting some of the pressure in the control spool chamber. As with the operation of the pressure compensator control, this allows the control

spool to move downward, venting the servo piston cavity and causing the servo piston to move to the right. This reduces output flow and thereby power.

As indicated in the pictorial drawing, pressure in the control spool chamber is affected by both the pressure compensator control and the power control. The resultant pressure in this chamber is a function of the set points of these two controls. Both set points are adjustable.

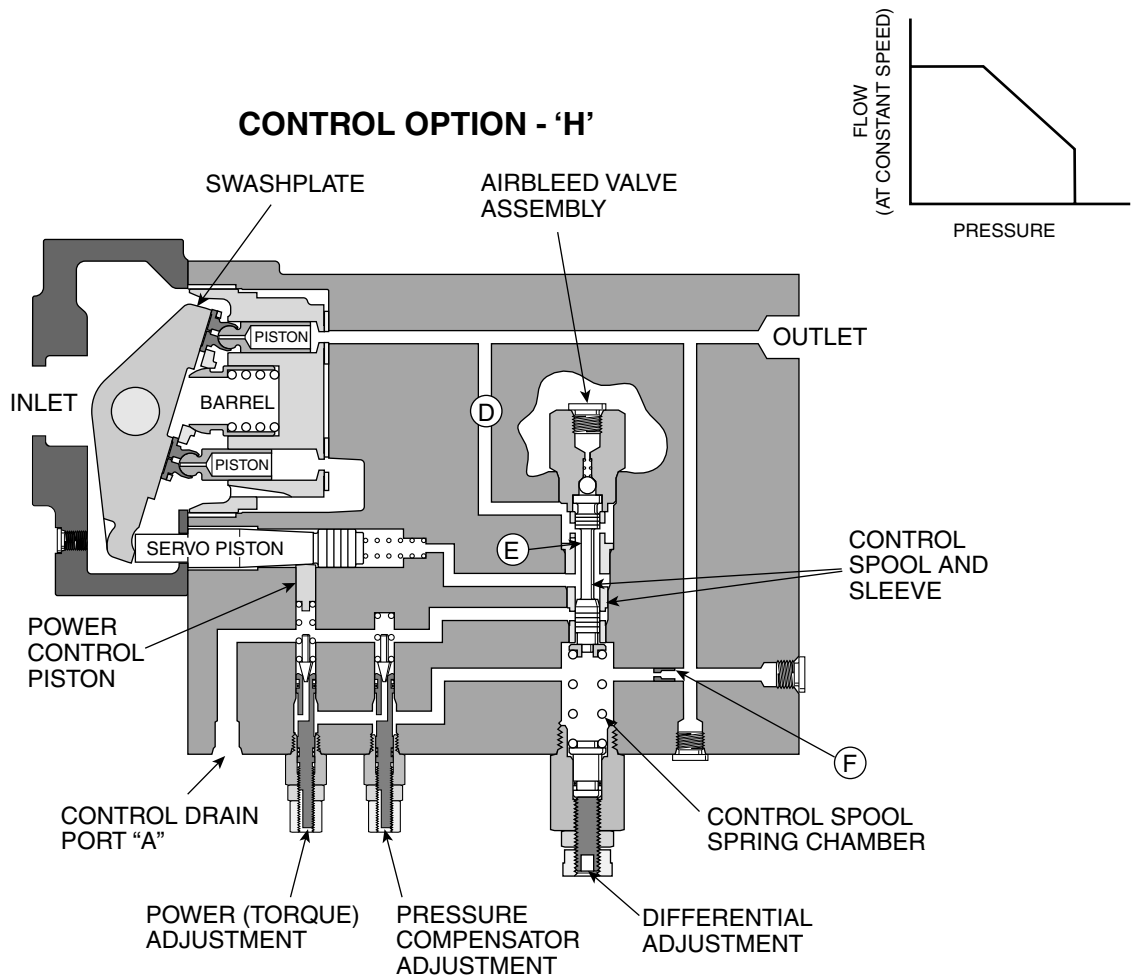



**How to read input power control curve data.**

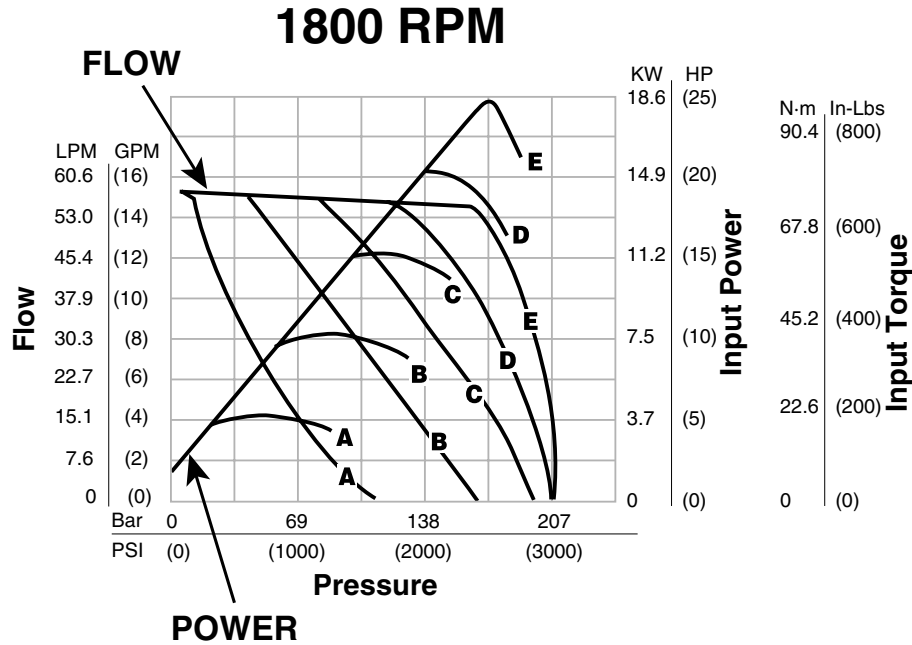

1. Power “A” curve corresponds to flow “A” curve. This represents a particular setting of the power (torque) control.
2. With this setting the maximum power required will be as shown at the apex (maximum point) of the power curve.
3. The flow at this setting will follow the flow vs. pressure curve shown.
4. Example – 1800 RPM, curve labeled “C”:  
 A. Flow will follow curve “C” and pump will deadhead at 190 bar (2750 PSI).  
 B. Full flow will not be realized above 83 bar (1200 PSI).  
 C. Flow at 103 bar (1500 PSI) will be approximately 48.1 LPM (12.7 GPM).  
 D. Maximum power [11 KW (15 HP)] occurs at approximately 117 bar (1700 PSI).
5. Torque values are shown to correspond to powers at speed shown.

**Pressure, Power & Flow Control  
 Control Type (C)**

In addition to the three control configurations just discussed, it is possible to combine all three control devices in one pump. In this mode, the position of the control spool is a function of the actions of the pressure compensator adjustment, power adjustment, and flow control.

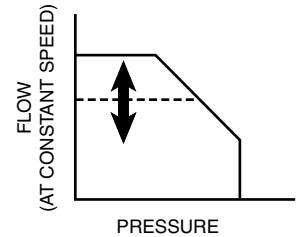

**CONTROL OPTION - 'C'**

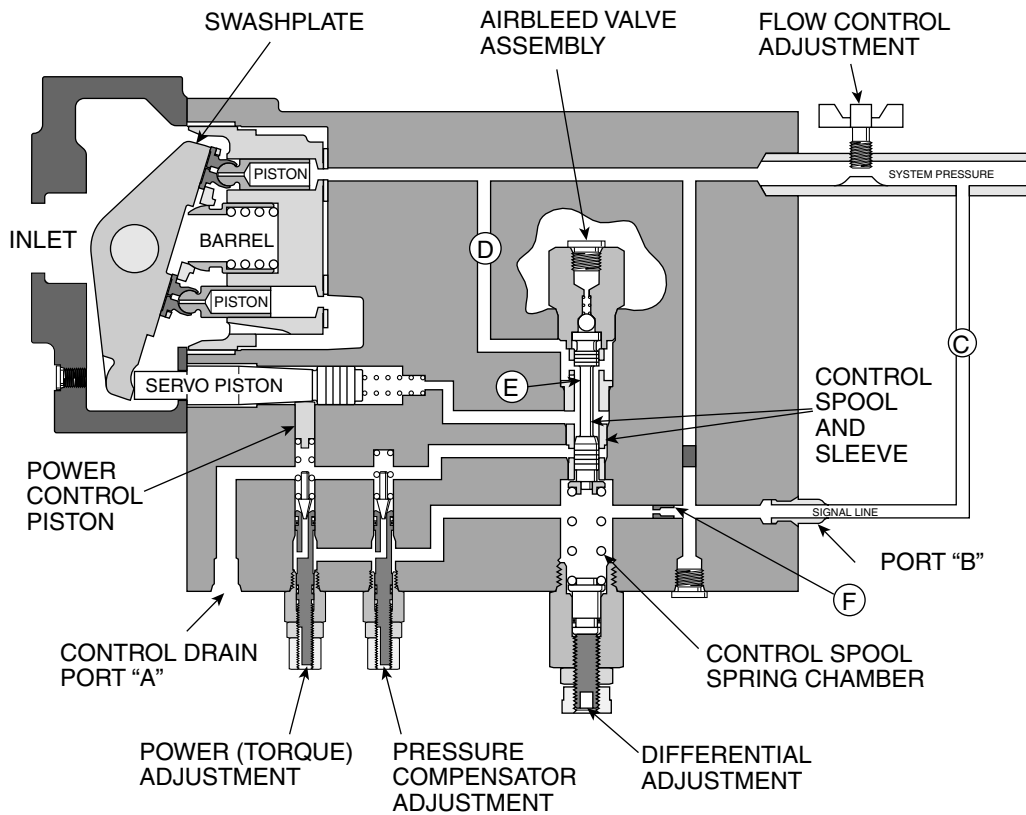



**Performance Information**

Series PAVC 33/38 Pressure Compensated, Variable Volume, Piston Pumps

**Features**

- High Strength Cast-Iron Housing
- Built-In Supercharger
- High Speed Capability – 3000 RPM
- Two Piece Design for Ease of Service
- Cartridge Type Controls – Field Changeable
- Replaceable Bronze Clad Port Plate
- Airbleed Standard for Quick Priming
- Hydrodynamic Cylinder Barrel Bearing
- Full Pressure Rating on Water Glycol Fluids
- Filtered and/or Cooled Drain Line Capable 7 bar (100 PSI) Maximum

**Controls**

- Pressure Compensation
- Remote Pressure Compensation
- Load Sensing
- Power (Torque) Limiting
- Power Limiting and Load Sensing
- Adjustable Maximum Volume Stop
- Electrohydraulic Flow and Pressure
- Low Pressure Standby

**Schematic Symbol**  
 (Basic Pump)

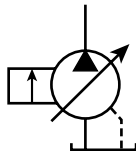

**Weight and Package Size**

Model	Weight In Kg (Lb)	Length From Mounting Face in CM (Inches)	Height in CM (Inches)	Width in CM (Inches)
PAVC 33/38	18 (40)	18.41 (7.25)	16.00 (6.30)	16.81 (6.62)

**Quick Reference Data Chart**

Pump Model	Displacement CM <sup>3</sup> /REV (IN <sup>3</sup> /REV)	Pump Delivery @ 21 bar (300 PSI) in LPM (GPM)		*Approximate Noise Levels dB(A) @ Full Flow 1800 RPM (1200 RPM)				Input Power At 1800 RPM, Max. Displacement & 207 bar (3000 PSI)
		1200 RPM	1800 RPM	34 bar (500 PSI)	69 bar (1000 PSI)	138 bar (2000 PSI)	207 bar (3000 PSI)	
				75 (69)	76 (72)	78 (75)	79 (77)	
PAVC33	33 (2.0)	39.4 (10.4)	59.0 (15.6)	75 (69)	76 (72)	78 (75)	79 (77)	21.3 kw (28.5 hp)
PAVC38	38 (2.3)	45.0 (11.9)	67.8 (17.9)	75 (69)	76 (72)	78 (75)	79 (77)	24.6 kw (33.0 hp)

\* Since many variables such as mounting, tank style, plant layout, etc., effect noise levels, it cannot be assumed that the above readings will be equal to those in the field. The above values are for guidance in selecting the proper pump. Noise levels are A-weighted, mean sound pressure levels at 1 meter from the pump, measured and recorded in accordance with applicable ISO and NFPA standards.



**Specifications**

Pressure Ratings:

Outlet Port: 207 bar (3000 PSI) Continuous (P1)  
 248 bar (3600 PSI) Peak (P3)

Inlet Port: 1.72 bar (25 PSI) Maximum  
 0.17 bar (5 In. Hg.) Minimum @ 1800 RPM (See Inlet Chart for other speeds)

Control Drain: 7 bar (100 PSI) Maximum

Speed Ratings: 600 to 3000 RPM

Operating Temperature Range: -40°C to 71°C  
 (-40°F to 160°F)

Housing Material: Cast-Iron

Filtration: Maintain SAE Class 4, ISO 16/13, ISO 18/15 Maximum Recommended

Mounting: SAE B 2-Bolt Flange Mount or Diagonally on SAE B 4-Bolt Flange Mount.

Installation Data: See page 46 of this catalog for specific recommendations pertaining to system cleanliness, fluids, start-up, inlet conditions, shaft alignment, drain line restrictions and other important factors relative to the proper installation and use of these pumps.

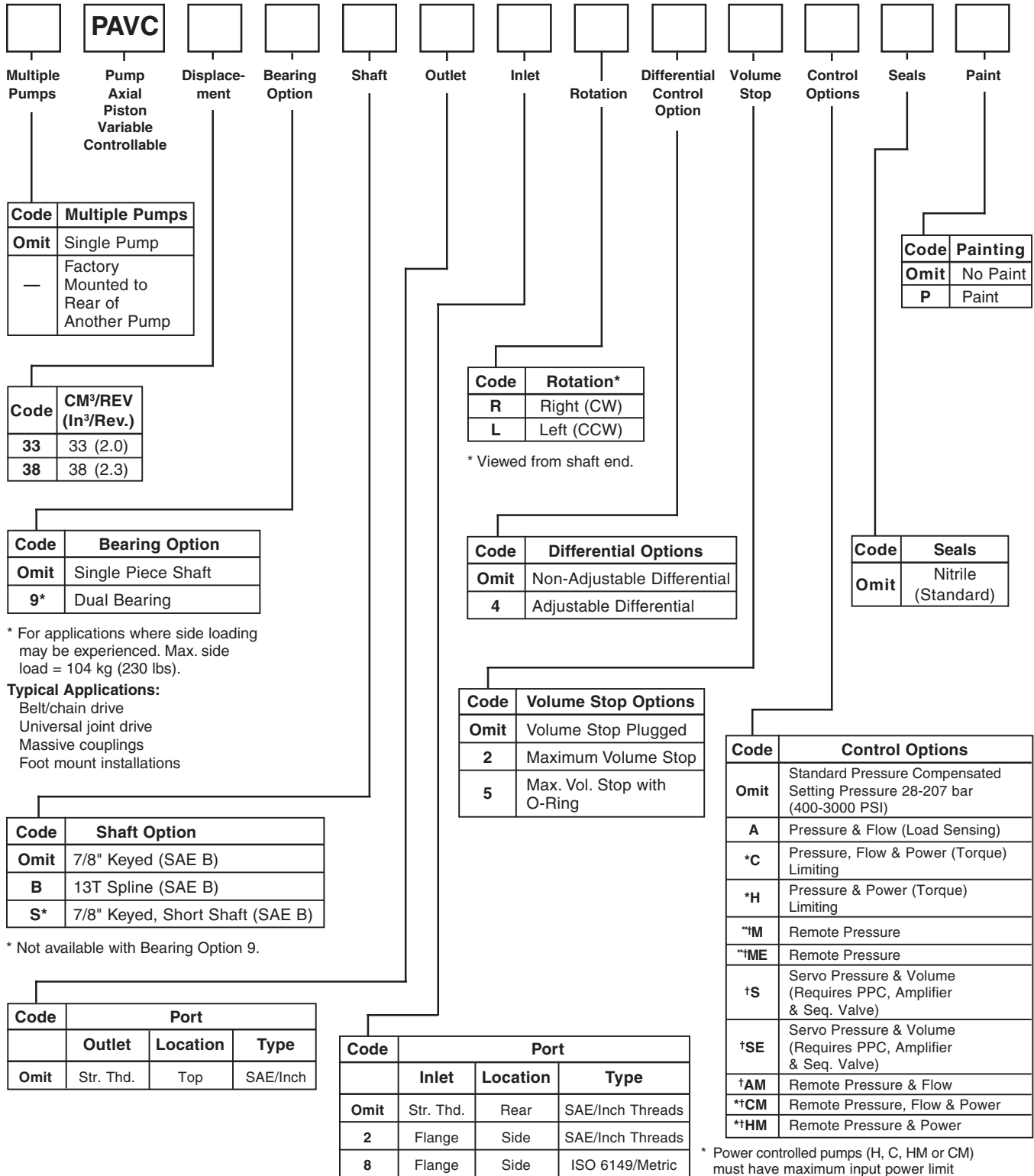

\* For applications where side loading may be experienced. Max. side load = 104 kg (230 lbs).

**Typical Applications:**

- Belt/chain drive
- Universal joint drive
- Massive couplings
- Foot mount installations

\* Not available with Bearing Option 9.

**Ordering Notes**

Unless otherwise specified, pump is shipped at maximum GPM (1800 RPM) and set to 69 bar (1000 PSI) [See † Exceptions]. When factory settings are required, the items shown in Chart #1 must be included with order.

Chart #1	
Item	
RPM	
PSI	
HP	
GPM	

\* Power controlled pumps (H, C, HM or CM) must have maximum input power limit specification at a particular drive speed (RPM), and compensator pressure (PSI) included with order. Power controlled pumps that do not have input power limit specifications, will be set at a default setting.  
 (7.5 HP @ 1800 RPM and 1000 PSI) "H" & "C"  
 (20 HP @ 1800 RPM and 3000 PSI) "HM" & "CM"

\*\* "M" (May be remotely controlled)  
 "ME" (Requires external pilot)

† Pumps with M, ME, S, SE, AM, CM or HM controls will be set to compensate at 207 bar (3000 PSI) unless Chart #1 otherwise specifies.

**Typical Performance Data - Fluid: Standard Hydraulic Oil 100 SSU @ 49°C (120°F)**

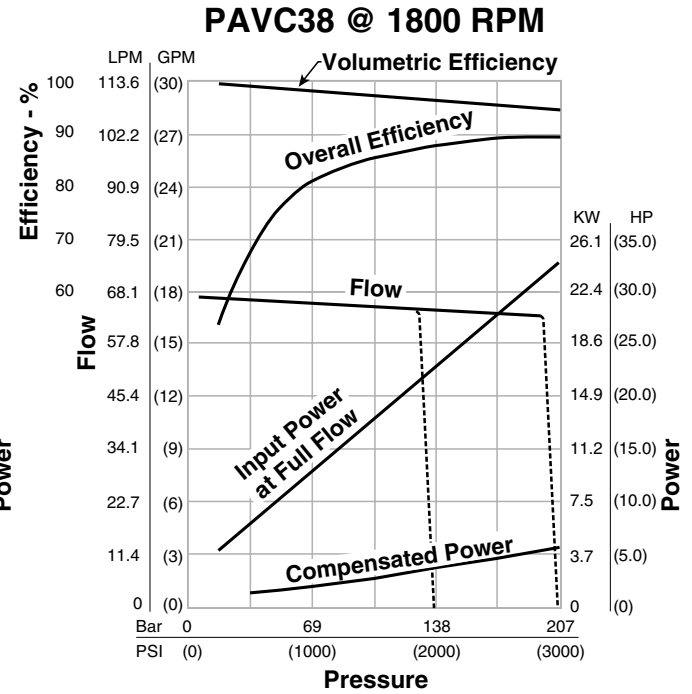
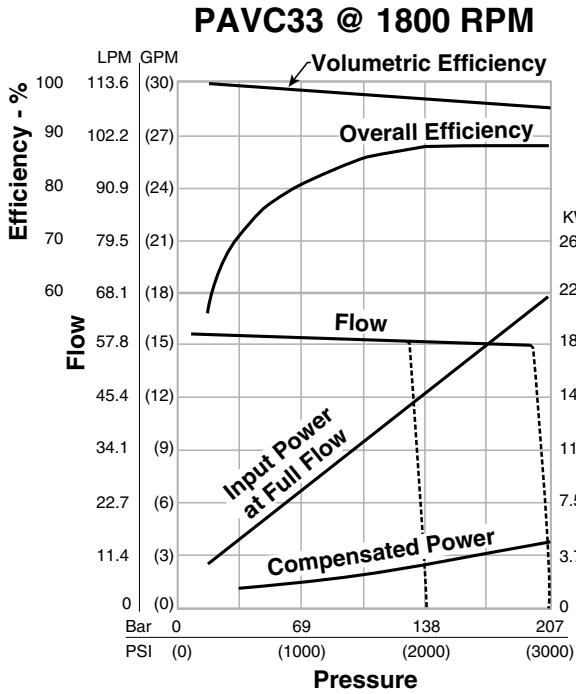

NOTE: The efficiencies and data in the graph are good only for pumps running at 1800 RPM and stroked to maximum. To calculate approximate input power for the other conditions, use the following formula:

$$HP = \left[ \frac{Q \times (PSI)}{1714} \right] + (CHp)$$

Actual GPM is directly proportional to drive speed and maximum volume setting. Flow loss, however, is a function of pressure only.

WHERE:

- Q = Actual Output Flow in GPM
- PSI = Pressure At Pump Outlet
- CHp = Input Power @ Full Compensation @ 1800 RPM (from graph read at operating pressure)

**Inlet Characteristics at Full Displacement**  
 (Graph only valid at sea level)

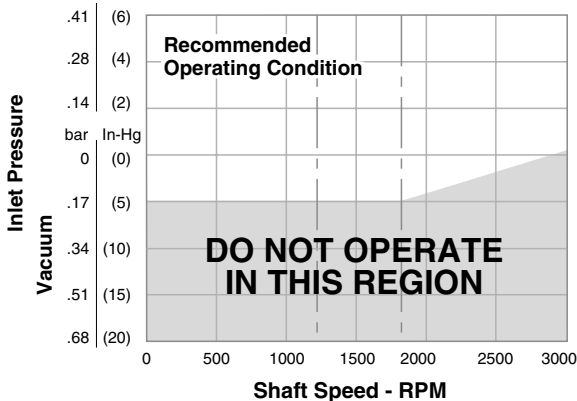

**Compensated Control Drain Flow @ 1800 RPM**

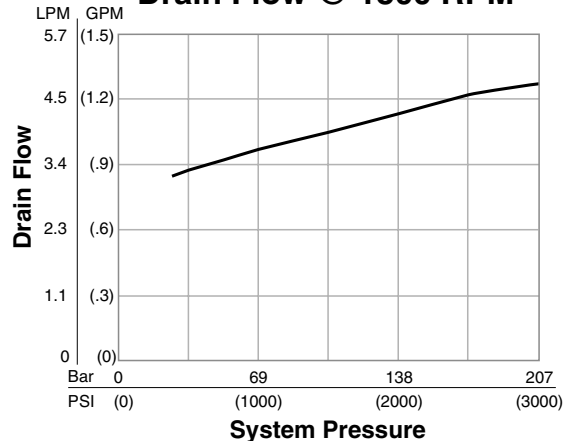



**Typical Performance Data -**

**Minimum Power Settings Attainable  
 With Control Options C, H, CM & HM**

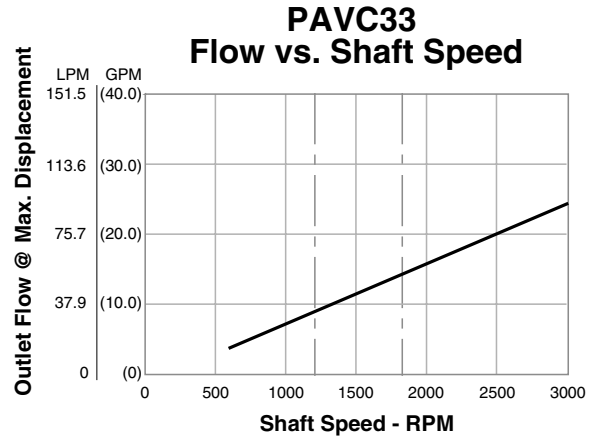
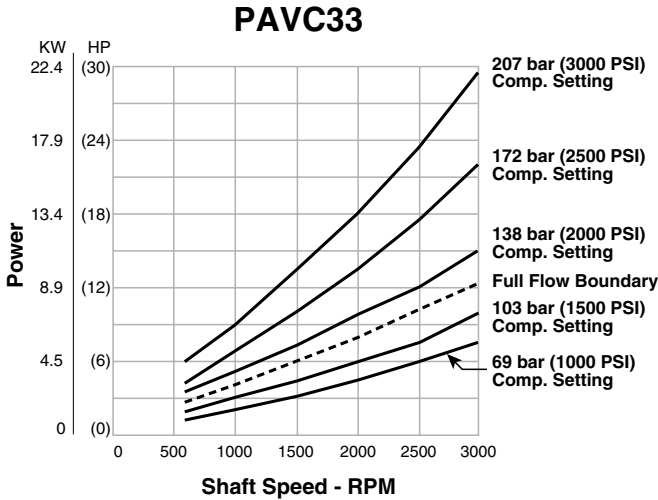

NOTE: Minimum attainable HP setting means that input power will not exceed the indicated setting at the indicated RPM and that the pump will achieve full compensator pressure selected. If setting input power limiter below full flow boundary, full flow may not be obtained at low operating pressure.

Determine maximum input power limitation at desired RPM. All points above desired compensator setting curve can be achieved.

**Power (Torque) Limiting Curves**

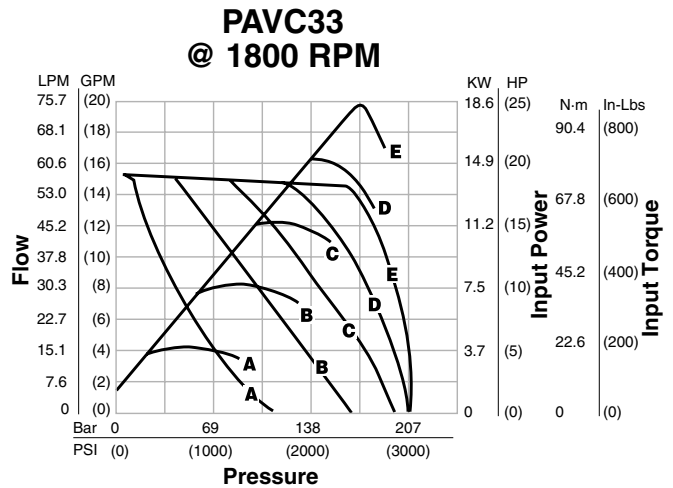
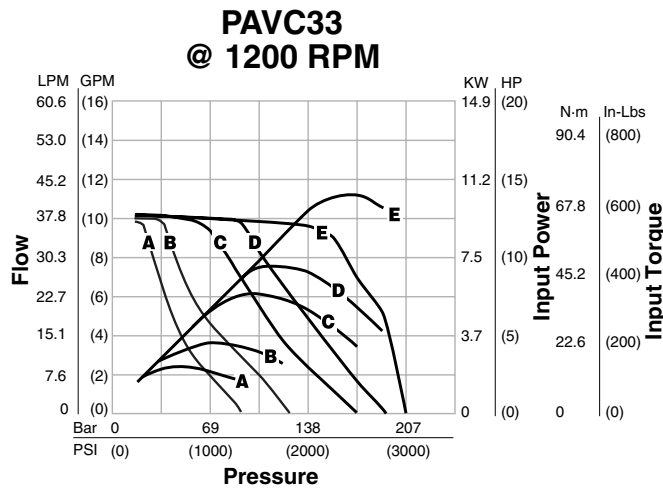

See page 9 for "How to Read Curves" information.

**Typical Performance Data -**

**Minimum Power Settings Attainable  
 With Control Options C, H, CM & HM**

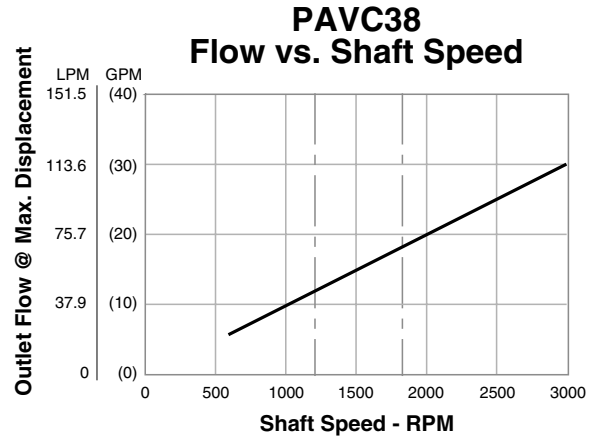
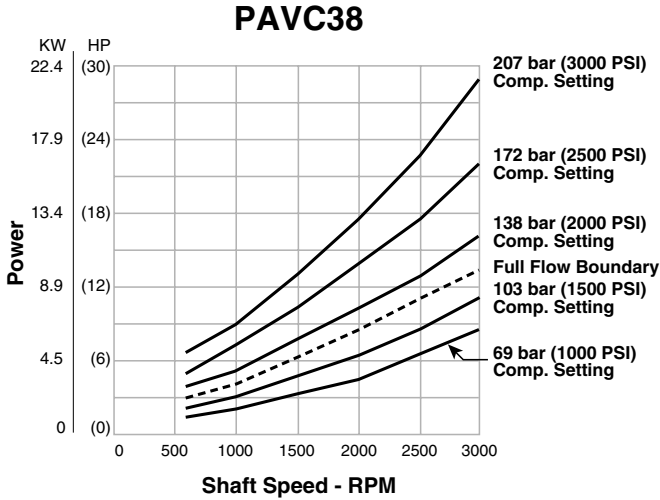

NOTE: Minimum attainable HP setting means that input horsepower will not exceed the indicated setting at the indicated RPM and that the pump will achieve full compensator pressure selected. If setting input power limiter below full flow boundary, full flow may not be obtained at low operating pressure.

Determine maximum input power limitation at desired RPM. All points above desired compensator setting curve can be achieved.

**Power (Torque) Limiting Curves**

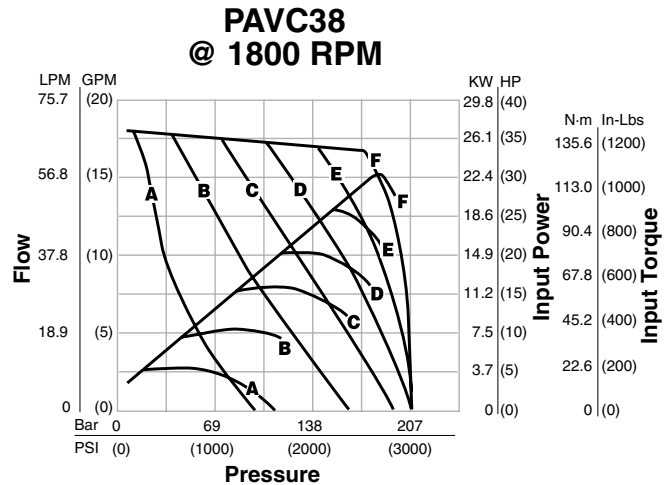
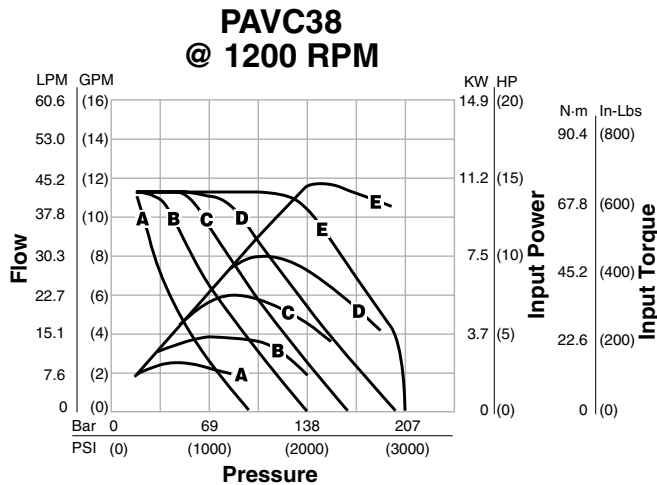

See page 9 for "How to Read Curves" information.

**Dimensional Data**

**Series PAVC 33/38**

**Rear Ported Pump Dimensions**

\* Inch equivalents for millimeter dimensions are shown in (\*\*).

**NOTE:**

1. Pump shown and dimensioned is a clockwise rotation pump. Outlet port, A and B ports, and controls will be on opposite side for a counterclockwise rotation pump.

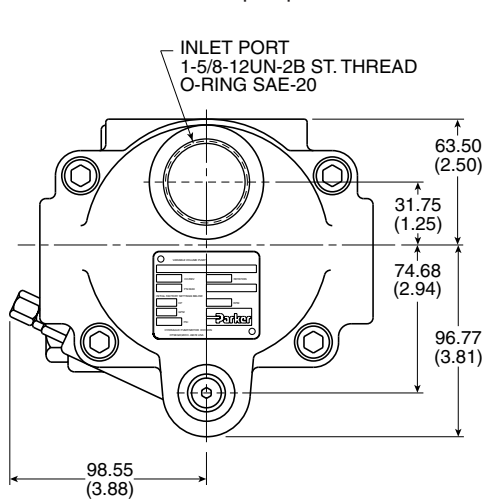

**Rear View**

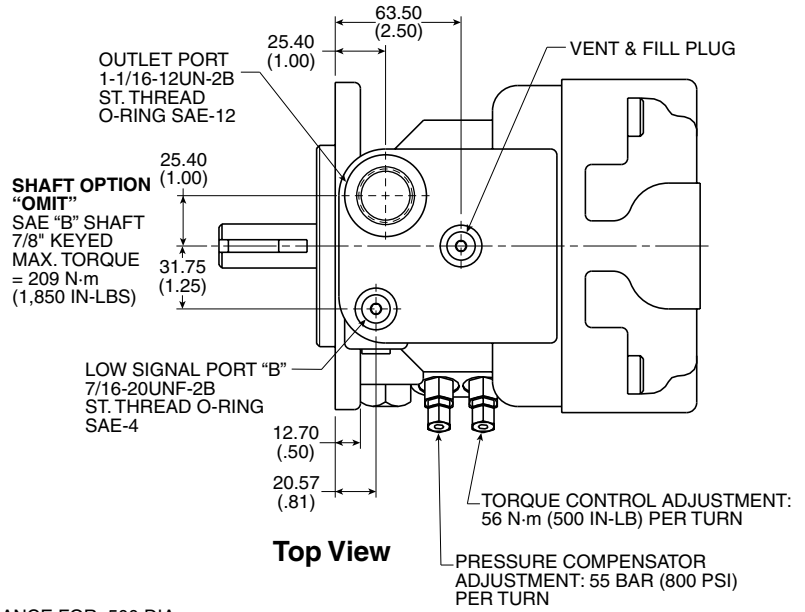

**Top View**

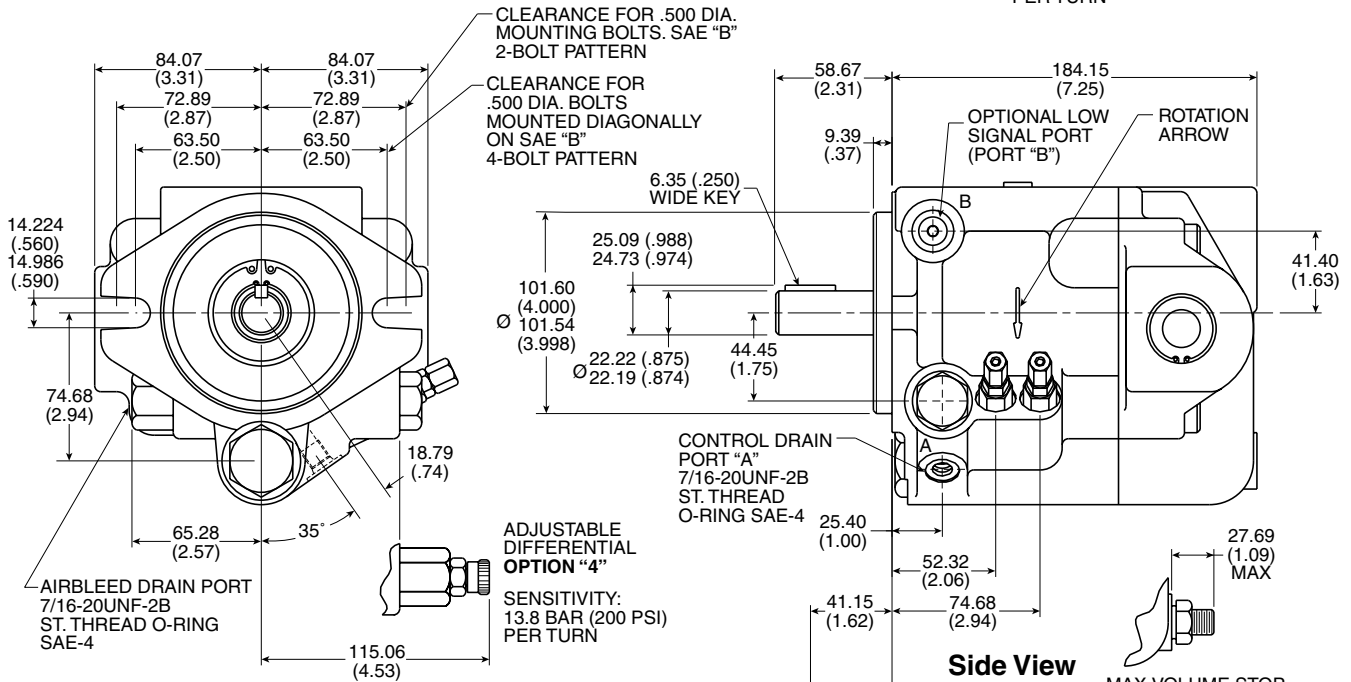

**Front View**

**Side View**

**SHAFT OPTION "S"**  
SAE "B" SHORT SHAFT  
7/8" KEYED  
MAX. TORQUE = 209 N·m (1,850 IN-LBS)

**SHAFT OPTION "B"**  
SAE "B" SPLINED SHAFT  
13 TOOTH  
16/32 PITCH  
MAX. TORQUE = 209 N·m (1,850 IN-LBS)

MAX. VOLUME STOP  
**OPTION "2"**  
2.2 CC/REV/TURN (PAVC33)  
2.5 CC/REV/TURN (PAVC38)

MAX. VOLUME STOP  
**OPTION "5"**  
2.5 CC/REV/TURN (PAVC33)  
2.8 CC/REV/TURN (PAVC38)

**Dimensional Data**

**Side Ported – Dimensions**

\* Inch equivalents for millimeter dimensions are shown in (\*\*).

**NOTE:**

1. Shown and dimensioned is a clockwise pump. Ports A and B, delivery port and pump controls will be on the opposite side for a counterclockwise pump.

Port Location				
Option	Outlet Port	Inlet Port	Control Drain	Signal Port
2	SAE-12 Straight Thread (1-1/16-12UNC)	1-1/4 SAE 4-Bolt Flange 7/16-14UNC Threads Standard Pressure Series (Code 61)	SAE-4 Straight Thread (7/16-20UNF)	SAE-4 Straight Thread (7/16-20UNF)
8	ISO 6149-12 Straight Thread (M27 x 2)	1-1/4 SAE 4-Bolt Flange M10 x 1.5 Threads Standard Pressure Series (Code 61)	ISO 6149-4 Straight Thread (M12 x 1.5)	ISO 6149-4 Straight Thread (M12 x 1.5)

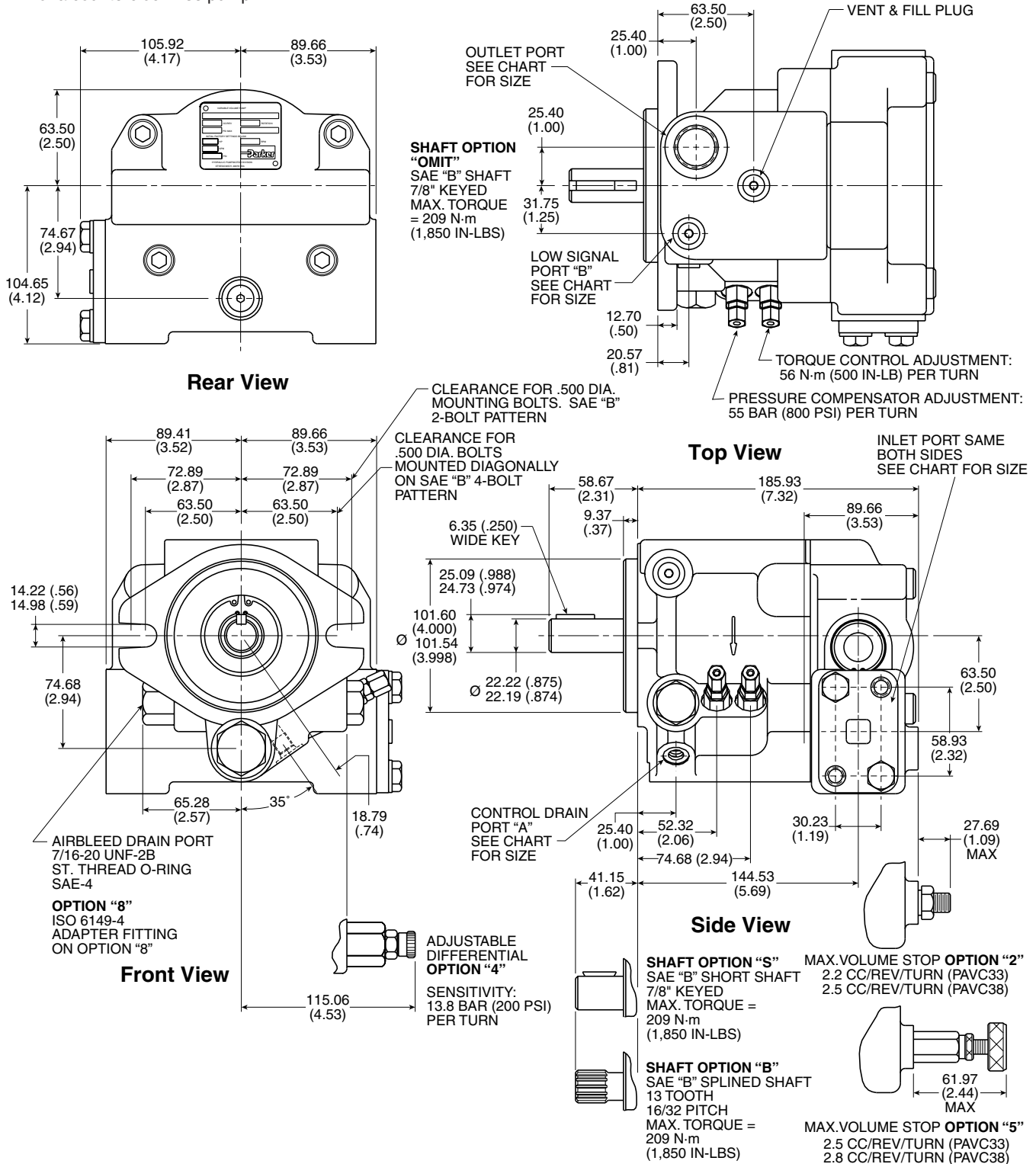

**Electrohydraulic Pump Dimensions**

\* Inch equivalents for millimeter dimensions are shown in (\*\*).

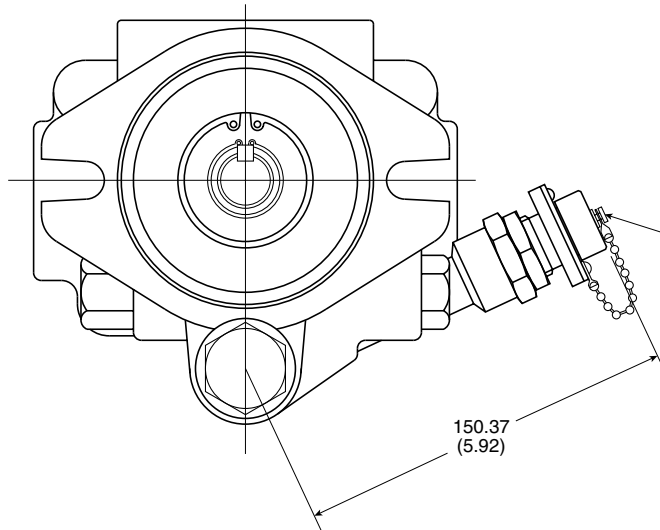

Accessories for S & SE Options	
PPC Valve (2500 PSI)	694586
PPC Valve (3000 PSI)	786645
Amp Single Pump	AP11
Amp Double Pump	AP211
Seq. Valve [150 LPM (40 GPM) Max.]	SX6PM8, SX6MM8 (Inline) (Manifold)
Electrohydraulic Cable [Pump to Amp]	EHC*4YB
Electrohydraulic Cable [PPC to Amp]	EHC*2AB

\* = Length in Feet

FEEDBACK CONNECTOR MS3102R14S-2PY  
 MATES WITH MS3106A14S-2SY  
 (PART NO. 800722)  
 ELECTROHYDRAULIC CABLE CAN BE  
 ORDERED AS EHC\*4Y\*

**NOTES:**

1. Consult factory for information relative to pump option selection and additional components required for desired pump function.
2. For electrohydraulic flow and pressure control of one or two pumps, make electrical connections per Figure IV. When one pump is used, omit connections to pump #2 feedback.
3. For electrohydraulic flow only, eliminate pressure command signal and place jumper between "Press CMD" and "+10V" terminals (compensating pressure will be controlled by maximum setting on pump or remote compensator if used).
4. For electrohydraulic pressure only, eliminate volume command signal and place jumper between "VOL CMD" and "+10V" terminals or use 801179 pressure driver card.
5. Figures I thru III show nominal input vs. output relationships. The actual values will vary with component tolerances. Full volume range will be realized with 0 to 7 volts. Full pressure range will be realized with 0 to 7 volts, or 0-500MA.
6. Pump shown is a clockwise rotation. For a counterclockwise rotation LVDT feedback is on opposite side.
7. For further detail on installation of AP11/AP211, refer to the latest edition of Catalog 2600-400-x/US.

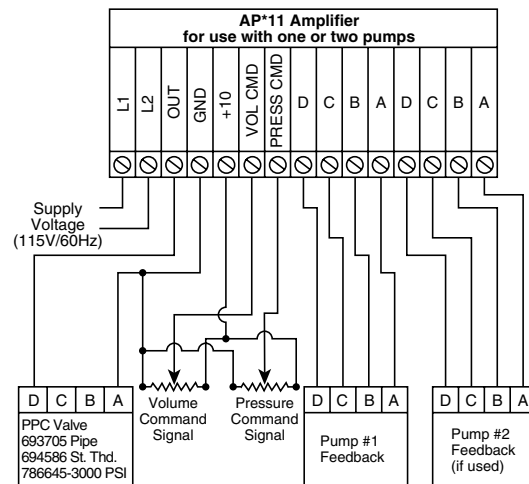

Typical Hookup for Infinitely Variable Electrohydraulic Pressure & Volume Control.

**Fig. IV**

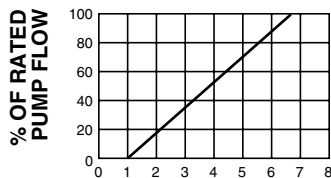

**Volume Command Voltage**

Nominal output flow vs. input command voltage when used in conjunction with AP\*11 amplifier and 786645 proportional pressure controller.

**Fig. I**

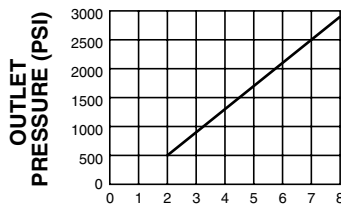

**Pressure Command Voltage**

Nominal output pressure vs. input command voltage when used in conjunction with AP\*11 amplifier and 786645 proportional pressure controller.

**Fig. II**

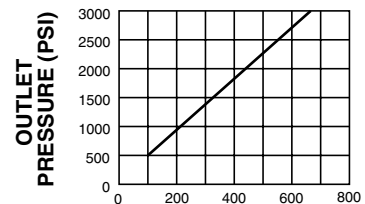

**Input Current (MA)**

Nominal input current vs. pressure when used in conjunction with a current source and 786645 proportional pressure controller.

**Fig. III**

**Performance Information**

Series PAVC65 Pressure Compensated, Variable Volume, Piston Pump

**Features**

- High Strength Cast-Iron Housing
- Built-In Supercharger
- High Speed Capability - 3000 RPM
- Two Piece Housing for Ease of Service
- Cartridge Type Controls - Field Changeable
- Replaceable Bronze Clad Port Plate
- Airbleed Standard for Quick Priming
- Hydrodynamic Cylinder Barrel Bearing
- Full Pressure Rating on Water Glycol Fluids
- Filtered and/or Cooled Drain Line Capable - 7 bar (100 PSI) Maximum

**Controls**

- Pressure Compensation
- Remote Pressure Compensation
- Load Sensing
- Power (Torque) Limiting
- Power Limiting and Load Sensing
- Adjustable Maximum Volume Stop
- Electrohydraulic Pressure
- Electrohydraulic Flow and Pressure (Servo Control)
- Low Pressure Standby

**Schematic Symbol**

(Basic Pump)

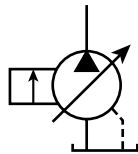

**Weight and Package Size**

Model	Weight In Kg (Lb)	Length From Mounting Face in CM (Inches)	Height in CM (Inches)	Width in CM (Inches)
PAVC65	28 (62)	22.40 (8.82)	18.84 (7.42)	20.32 (8.00)

**Quick Reference Data Chart**

Pump Model	Displacement CM <sup>3</sup> /REV (IN <sup>3</sup> /REV)	Pump Delivery @ 21 bar (300 PSI) in LPM (GPM)		*Approximate Noise Levels dB(A) @ Full Flow 1800 RPM (1200 RPM)				Input Power At 1800 RPM, Max. Displacement & 207 bar (3000 PSI)
		1200 RPM	1800 RPM	34 bar (500 PSI)	69 bar (1000 PSI)	138 bar (2000 PSI)	207 bar (3000 PSI)	
				77 (75)	78 (76)	80 (78)	81 (79)	
PAVC65	65 (4.0)	78.7 (20.8)	118.1 (31.2)	77 (75)	78 (76)	80 (78)	81 (79)	43.1 kw (57.8 hp)

\* Since many variables such as mounting, tank style, plant layout, etc., effect noise levels, it cannot be assumed that the above readings will be equal to those in the field. The above values are for guidance in selecting the proper pump. Noise levels are A-weighted, mean sound pressure levels at 1 meter from the pump, measured and recorded in accordance with applicable ISO and NFPA standards.

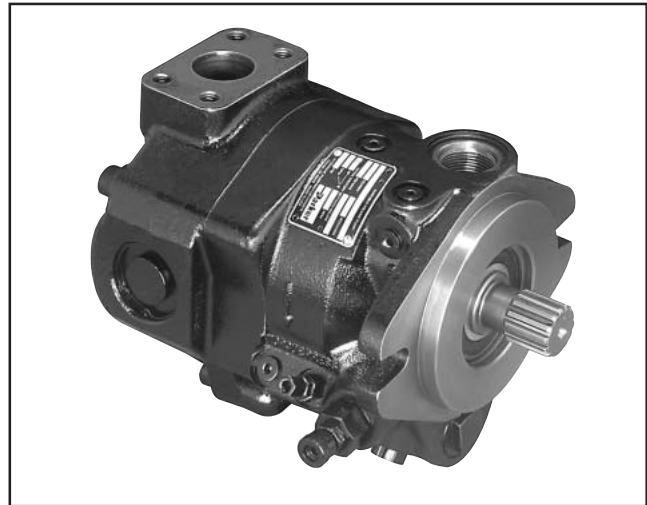

**Specifications**

Pressure Ratings:

Outlet Port: 207 bar (3000 PSI) Continuous (P1)  
 248 bar (3600 PSI) Peak (P3)

Inlet Port: 1.7 bar (25 PSI) Maximum  
 0.17 bar (5 In. Hg.) Minimum  
 @ 1800 RPM (See Inlet Chart for other speeds)

Control Drain: 7 bar (100 PSI) Maximum

Speed Ratings: 600 to 3000 RPM\*

\* See Inlet Characteristics Chart on page A155 and consider using Dual Inlet Port configuration on page A178 for applications above 2700 RPM.

Operating Temperature Range: -40°C to 71°C  
 (-40°F to 160°F)

Housing Material: Cast-Iron

Filtration: Maintain SAE Class 4, ISO 16/13, ISO 18/15 Maximum Recommended

Mounting: SAE C 2-Bolt Flange Mount or Diagonally on SAE C 4-Bolt Flange Mount

Installation Data: See page 46 of this catalog for specific recommendations pertaining to system cleanliness, fluids, start-up, inlet conditions, shaft alignment, drain line restrictions and other important factors relative to the proper installation and use of these pumps.



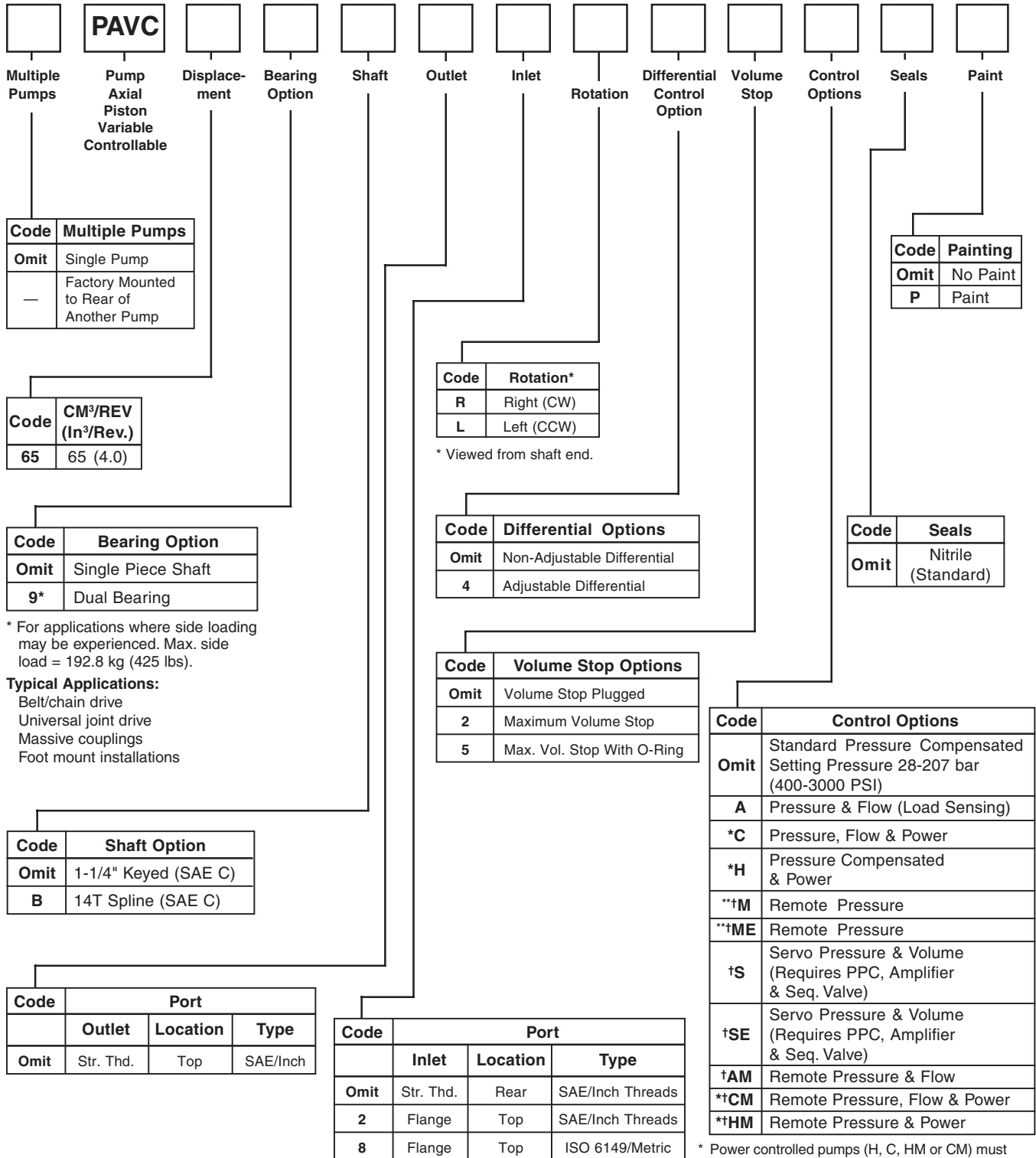

\* For applications where side loading may be experienced. Max. side load = 192.8 kg (425 lbs).

**Typical Applications:**

- Belt/chain drive
- Universal joint drive
- Massive couplings
- Foot mount installations

**Ordering Notes**

Unless otherwise specified, pump is shipped at maximum GPM (1800 RPM) and set to 69 bar (1000 PSI) [See † Exceptions]. When factory settings are required, the items shown in Chart #1 must be included with order.

Chart #1	
Item	
RPM	
PSI	
HP	
GPM	

\* Power controlled pumps (H, C, HM or CM) must have maximum input power limit specification at a particular drive speed (RPM) and compensator pressure setting (PSI) included with order. Power controlled pumps that do not have input power limit specifications, will be set at a default setting. (15 HP @ 1800 RPM and 1000 PSI) "H" & "C" (40 HP @ 1800 RPM and 3000 PSI) "HM" & "CM"

\*\* "M" (May be remotely controlled)  
 "ME" (Requires external pilot)

† Pumps with M, ME, AM, CM or HM controls will be set to compensate at 207 bar (3000 PSI) unless Chart #1 otherwise specifies.

**Typical Performance Data - Fluid: Standard Hydraulic Oil 100 SSU @ 49°C (120°F)**

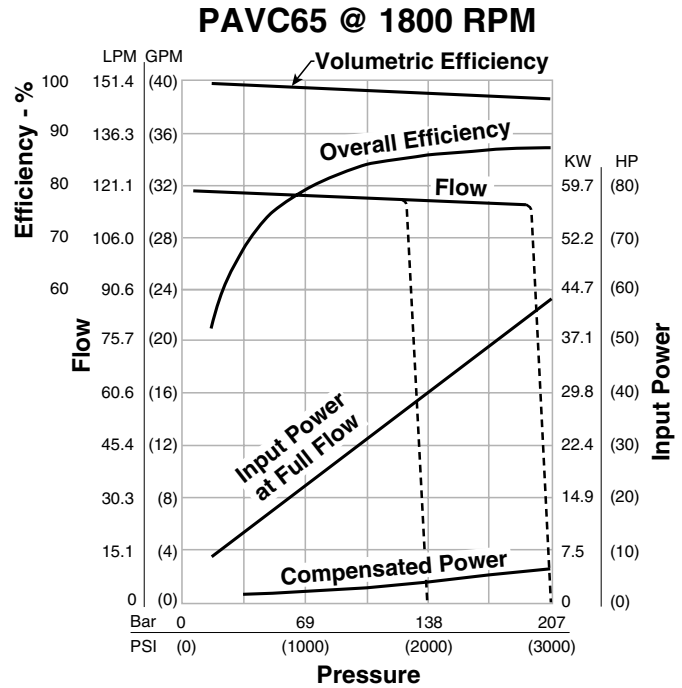
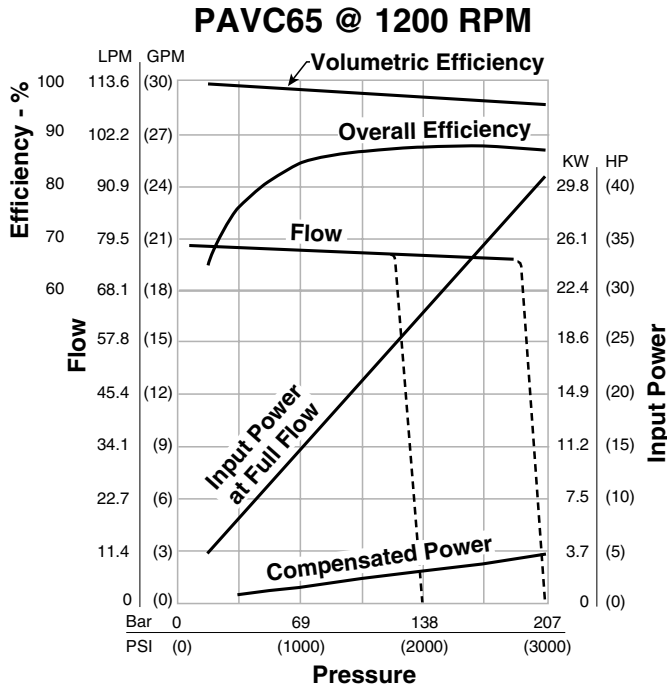

NOTE: The efficiencies and data in the graph are good only for pumps running at 1800 RPM and stroked to maximum. To calculate approximate input power for the other conditions, use the following formula:

$$HP = \left[ \frac{Q \times (PSI)}{1714} \right] + (CHp)$$

WHERE:

- Q = Actual Output Flow in GPM
- PSI = Pressure At Pump Outlet
- CHp = Input Power @ Full Compensation @ 1800 RPM (from graph read at operating pressure)

Actual GPM is directly proportional to drive speed and maximum volume setting. Flow loss, however, is a function of pressure only.

**Inlet Characteristics at Full Displacement**  
 (Graph only valid at sea level)

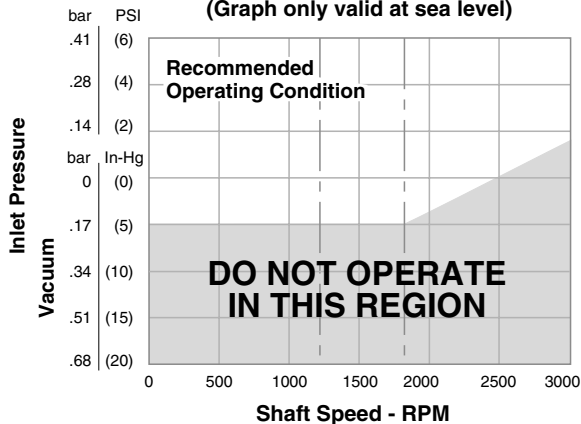

**Compensated Control Drain Flow @ 1800 RPM**

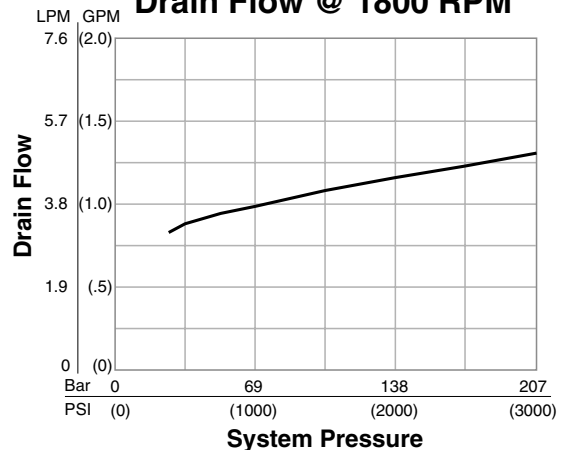

**Typical Performance Data -**

**Minimum Power Settings Attainable  
 With Control Options C, H, CM & HM**

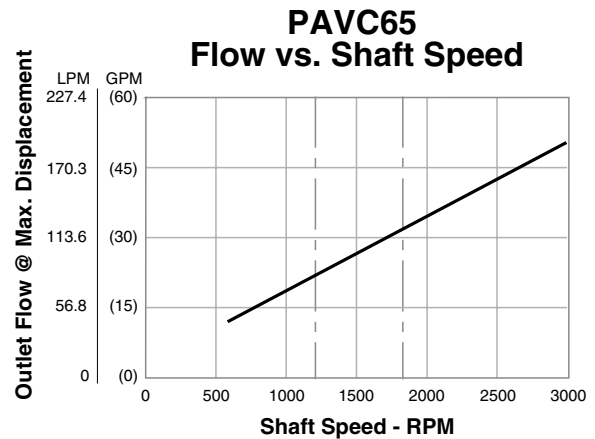
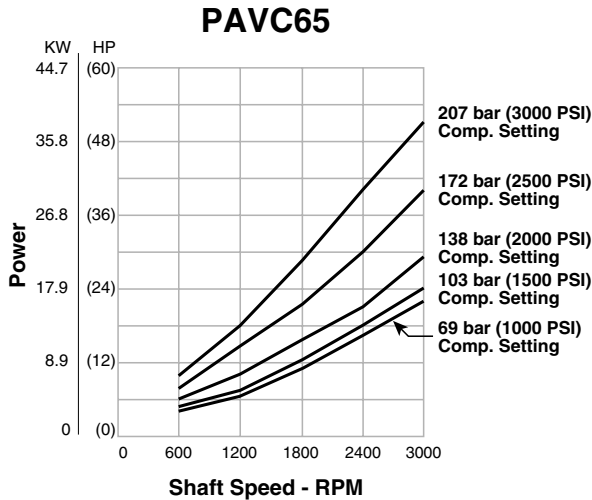

NOTE: Minimum attainable HP setting means that input power will not exceed the indicated setting at the indicated RPM and that the pump will achieve full compensator pressure selected. If setting input power limiter below full flow boundary, full flow may not be obtained at low operating pressure.

Determine maximum input power limitation at desired RPM. All points above desired compensator setting curve can be achieved.

**Power (Torque) Limiting Curves**

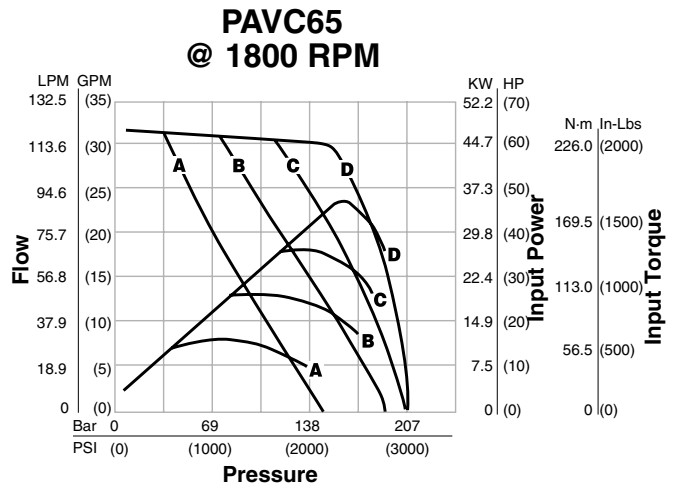
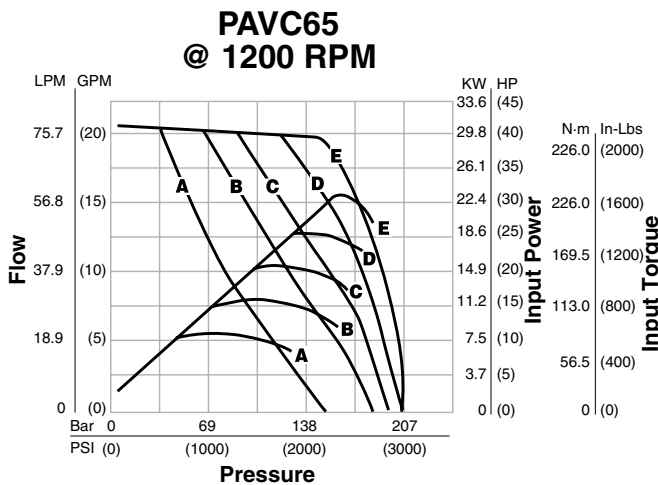

See page 9 for "How to Read Curves" information.

**Dimensional Data**

**Dimensions – Rear Port**

\* Inch equivalents for millimeter dimensions are shown in (\*\*).

**NOTES:**

1. Pump shown and dimensioned is a clockwise rotation pump. Outlet port, A and B ports, and controls will be on opposite side for a counterclockwise rotation pump.
2. Pump mounting and shaft comply with SAE "C" dimensions.

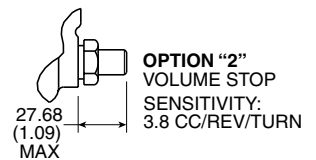
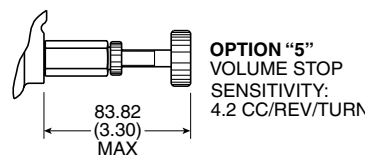
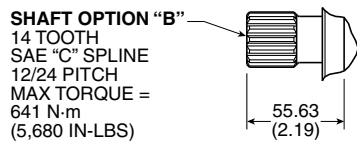
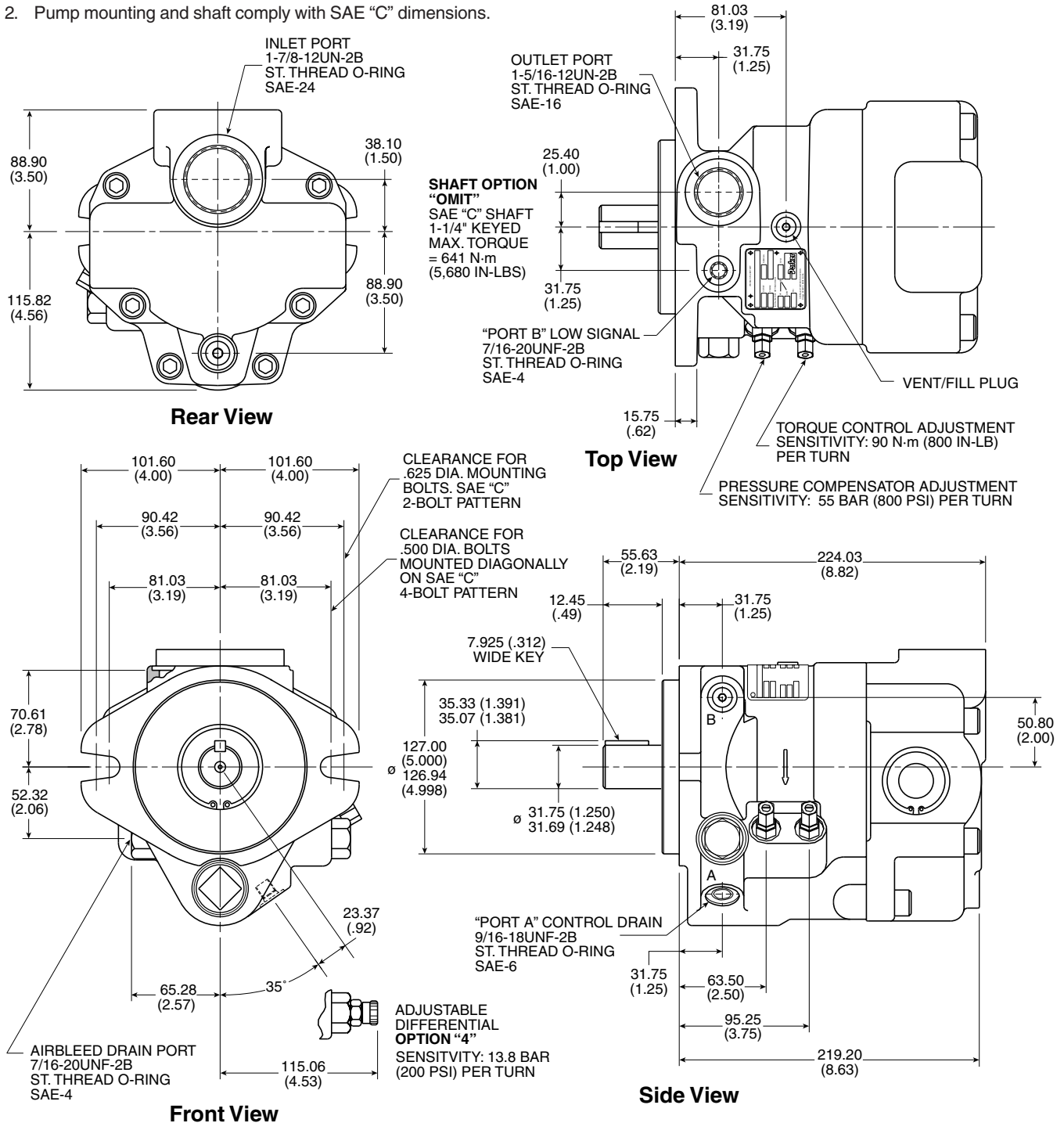

**Dimensional Data**

**Dimensions – Top Port**

\* Inch equivalents for millimeter dimensions are shown in (\*\*).

**NOTES:**

1. Pump shown and dimensioned is a clockwise rotation pump. Outlet port, A and B ports, and controls will be on opposite side for a counterclockwise pump.
2. Pump mounting and shaft comply with SAE "C" dimensions.

Port Location				
Option	Outlet Port	Inlet Port	Control Drain	Signal Port
2	SAE-16 Straight Thread (1-5/16-12UNC)	1-1/2 SAE 4-Bolt Flange 1/2-13UNC Threads Standard Pressure Series (Code 61)	SAE-6 Straight Thread (9/16-18UNF)	SAE-4 Straight Thread (7/16-20UNF)
8	ISO 6149-16 Straight Thread (M33 x 2)	1-1/2 SAE 4-Bolt Flange M12 x 1.75 Threads Standard Pressure Series (Code 61)	ISO 6149-5 Straight Thread (M14 x 1.5)	ISO 6149-4 Straight Thread (M12 x 1.5)

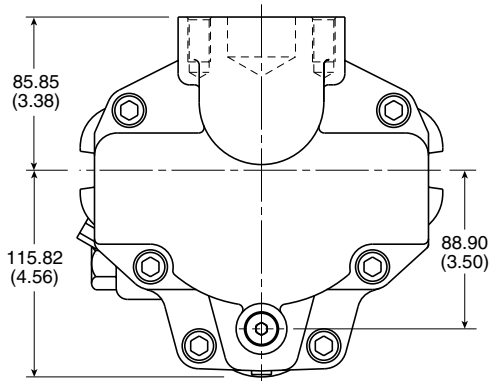

**Rear View**

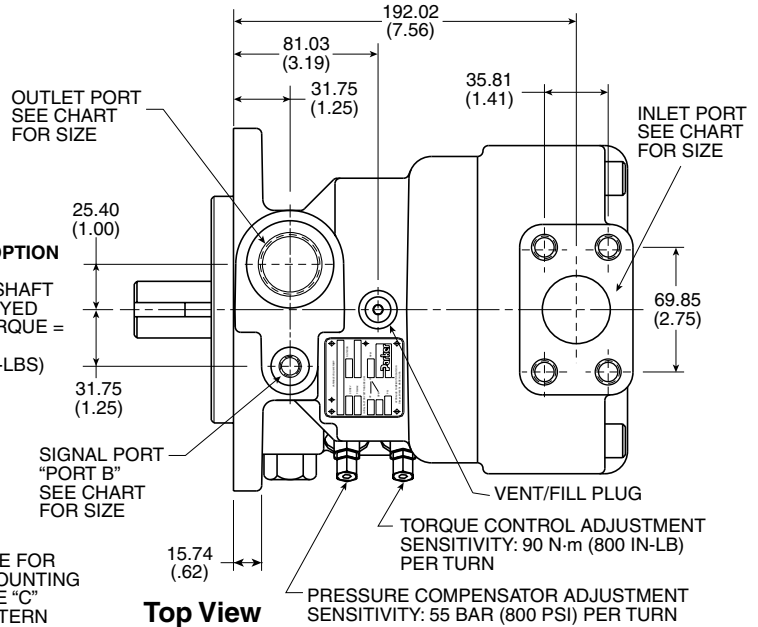

**Top View**

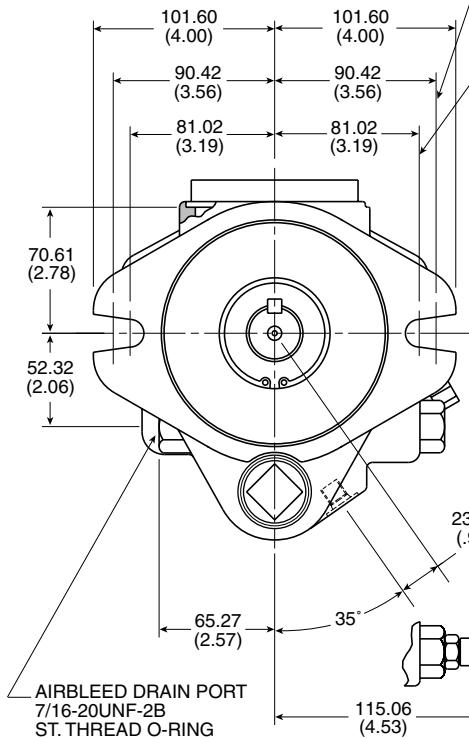

**Front View**

CLEARANCE FOR .625 DIA. MOUNTING BOLTS. SAE "C" 2-BOLT PATTERN

CLEARANCE FOR .500 DIA. BOLTS MOUNTED DIAGONALLY ON SAE "C" 4-BOLT PATTERN

ADJUSTABLE DIFFERENTIAL OPTION "4"  
SENSITIVITY: 13.8 BAR (200 PSI) PER TURN

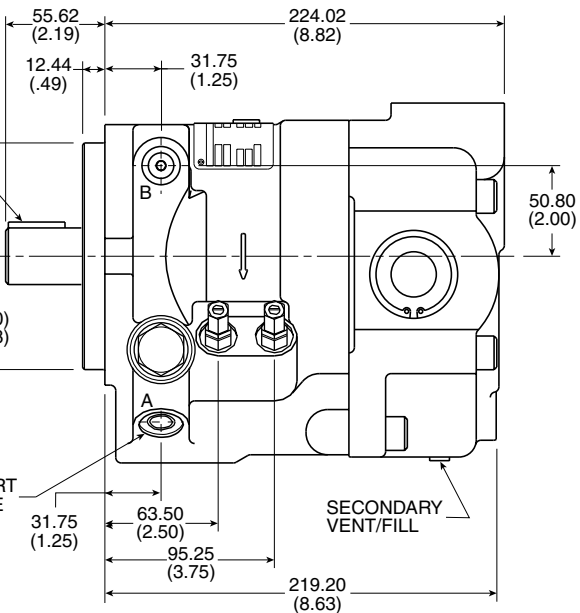

**Side View**

OPTION "8"  
ISO 6149-4  
ADAPTER FITTING  
ON OPTION "8"

SHAFT OPTION "B"  
14 TOOTH  
SAE "C" SPLINE  
12/24 PITCH  
MAX. TORQUE =  
641 N·m (5,680 IN-LBS)

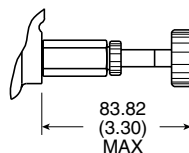
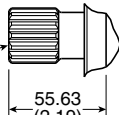

OPTION "5"  
VOLUME STOP  
SENSITIVITY:  
4.2 CC/REV/TURN

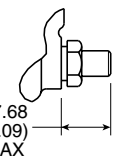

OPTION "2"  
VOLUME STOP  
SENSITIVITY:  
3.8 CC/REV/TURN

**Dimensions – Electrohydraulic Pump**

\* Inch equivalents for millimeter dimensions are shown in (\*\*).

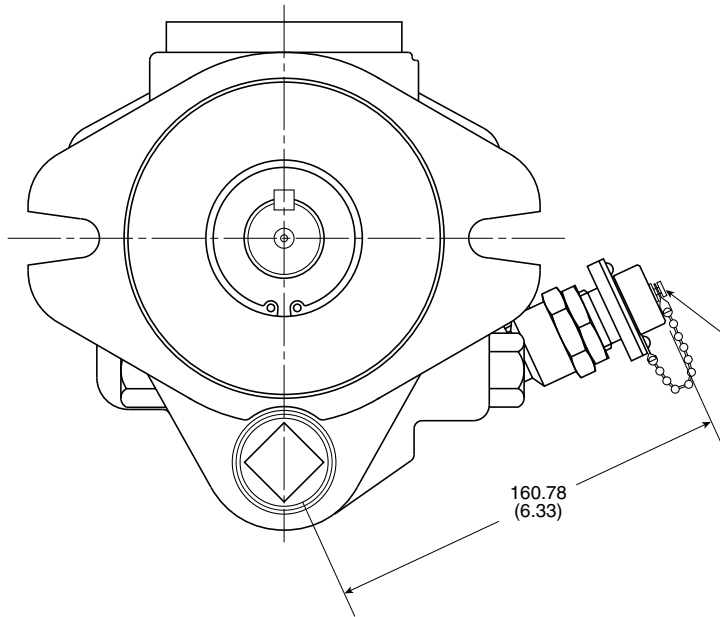

Accessories for S & SE Options	
PPC Valve (2500 PSI)	694586
PPC Valve (3000 PSI)	786645
Amp Single Pump	AP11
Amp Double Pump	AP211
Seq. Valve [150 LPM (40 GPM) Max.]	SX6PM8, SX6MM8 (Inline) (Manifold)
Seq. Valve [340 LPM (90 GPM) Max.]	SX10PM8, SX10MM8 (Inline) (Manifold)
Electrohydraulic Cable [Pump to Amp]	EHC*4YB
Electrohydraulic Cable [PPC to Amp]	EHC*2AB

\* = Length in Feet

FEEDBACK CONNECTOR MS3102R14S-2PY  
 MATES WITH MS3106A14S-2SY  
 (PART NO. 800722)  
 ELECTROHYDRAULIC CABLE CAN BE  
 ORDERED AS EHC\*4Y\*

**SHOWN WITH “S” OR “SE” OPTION**

**NOTES:**

1. Consult factory for information relative to pump option selection and additional components required for desired pump function.
2. For electrohydraulic flow and pressure control of one or two pumps, make electrical connections per Figure IV. When one pump is used, omit connections to pump #2 feedback.
3. For electrohydraulic flow only, eliminate pressure command signal and place jumper between “Press CMD” and “+10V” terminals (compensating pressure will be controlled by maximum setting on pump or remote compensator if used).
4. For electrohydraulic pressure only, eliminate volume command signal, and place jumper between “VOL CMD” and “+10V” terminals or use 801179 pressure driver card.
5. Figures I thru III show nominal input vs. output relationships. The actual values will vary with component tolerances. Full volume range will be realized with 0 to 7 volts. Full pressure range will be realized with 0 to 7 volts, or 0-500MA.
6. Pump shown is a clockwise rotation. For a counterclockwise rotation LVDT feedback is on opposite side.
7. For further detail on installation of AP11/AP211, refer to the latest edition of Catalog 2600-400-x/US.

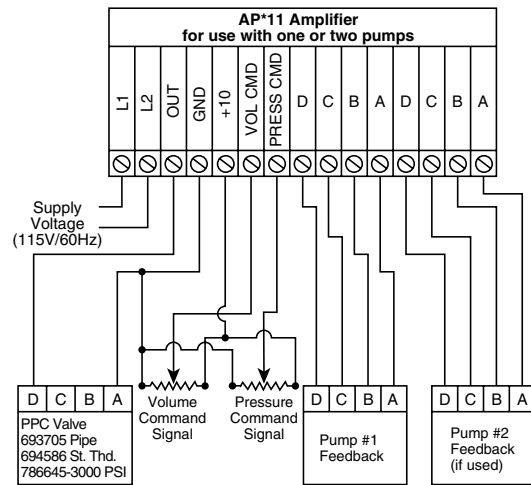

Typical Hookup for Infinitely Variable Electrohydraulic Pressure & Volume Control.

**Fig. IV**

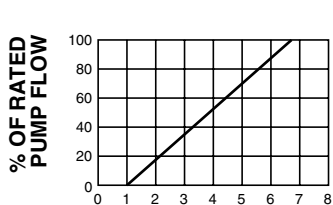

**Volume Command Voltage**

Nominal output flow vs. input command voltage when used in conjunction with AP\*11 amplifier and 786645 proportional pressure controller.

**Fig. I**

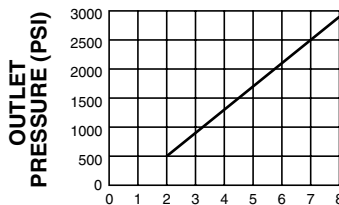

**Pressure Command Voltage**

Nominal output pressure vs. input command voltage when used in conjunction with AP\*11 amplifier and 786645 proportional pressure controller.

**Fig. II**

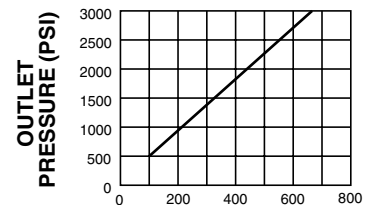

**Input Current (MA)**

Nominal input current vs. pressure when used in conjunction with a current source and 786645 proportional pressure controller.

**Fig. III**





## Performance Information

Series PAVC100 Pressure Compensated, Variable Volume, Piston Pump

### Features

- High Strength Cast-Iron Housing
- Built-In Supercharger
- High Speed Capability - 2600 RPM
- Cartridge Type Controls - Field Changeable
- Replaceable Bronze Clad Port Plate
- Airbleed Standard for Quick Priming
- Hydrodynamic Cylinder Barrel Bearing
- Full Pressure Rating on Water Glycol Fluids
- Filtered and/or Cooled Drain Line Capable 7 bar (100 PSI) Maximum
- Thru-Shaft Capable

### Controls

- Pressure Compensation
- Remote Pressure Compensation
- Load Sensing
- Power (Torque) Limiting
- Power Limiting and Load Sensing
- Adjustable Maximum Volume Stop
- Electrohydraulic Pressure
- Electrohydraulic Flow and Pressure (Servo Control)
- Low Pressure Standby

### Schematic Symbol (Basic Pump)

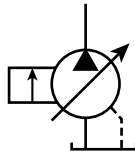

### Weight and Package Size

Model	Weight In Kg (Lb)	Length From Mounting Face in CM (Inches)	Height in CM (Inches)	Width in CM (Inches)
PAVC100	50 (110)	30.73 (12.10)	24.90 (9.82)	21.59 (8.50)

### Quick Reference Data Chart

Pump Model	Displacement CM <sup>3</sup> /REV (IN <sup>3</sup> /REV)	Pump Delivery @ 21 bar (300 PSI) in LPM (GPM)		*Approximate Noise Levels dB(A) @ Full Flow 1800 RPM (1200 RPM)			Input Power At 1800 RPM, Max. Displacement & 207 bar (3000 PSI)
		1200 RPM	1800 RPM	69 bar (1000 PSI)	138 bar (2000 PSI)	207 bar (3000 PSI)	
PAVC100	100 (6.1)	119.6 (31.6)	179.8 (47.5)	82 (78)	82 (79)	85 (80)	71.2 kw (95.5 hp)

\* Since many variables such as mounting, tank style, plant layout, etc., effect noise levels, it cannot be assumed that the above readings will be equal to those in the field. The above values are for guidance in selecting the proper pump. Noise levels are A-weighted, mean sound pressure levels at 1 meter from the pump, measured and recorded in accordance with applicable ISO and NFPA standards.

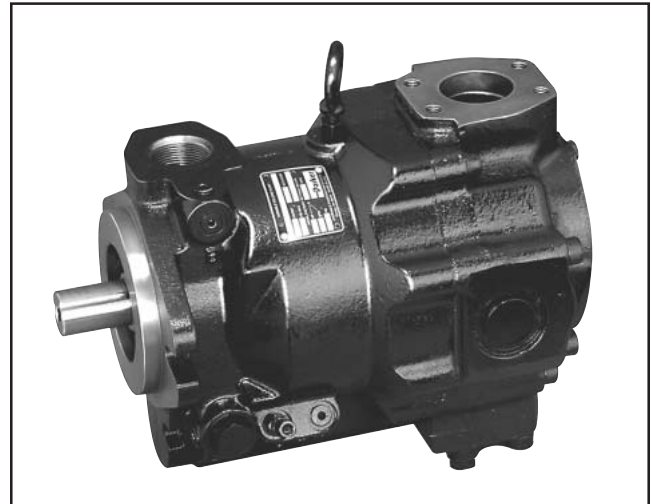

### Specifications

Pressure Ratings:

Outlet Port: 207 bar (3000 PSI) Continuous (P1)  
 248 bar (3600 PSI) Peak (P3)

Inlet Port: 1.7 bar (25 PSI) Maximum  
 0.17 bar (5 In. Hg.) Minimum  
 @ 1800 RPM (See Inlet Chart for other speeds)

Control Drain: 7 bar (100 PSI) Maximum

Speed Ratings: 600 to 2600 RPM

Operating Temperature Range: -40°C to 71°C  
 (-40°F to 160°F)

Housing Material: Cast-Iron

Filtration: Maintain SAE Class 4, ISO 16/13,  
 ISO 18/15 Maximum Recommended

Mounting: SAE C 2-Bolt Flange Mount or Diagonally  
 on SAE C 4-Bolt Flange Mount

Installation Data: See page 46 of this catalog for specific recommendations pertaining to system cleanliness, fluids, start-up, inlet conditions, shaft alignment, drain line restrictions and other important factors relative to the proper installation and use of these pumps.

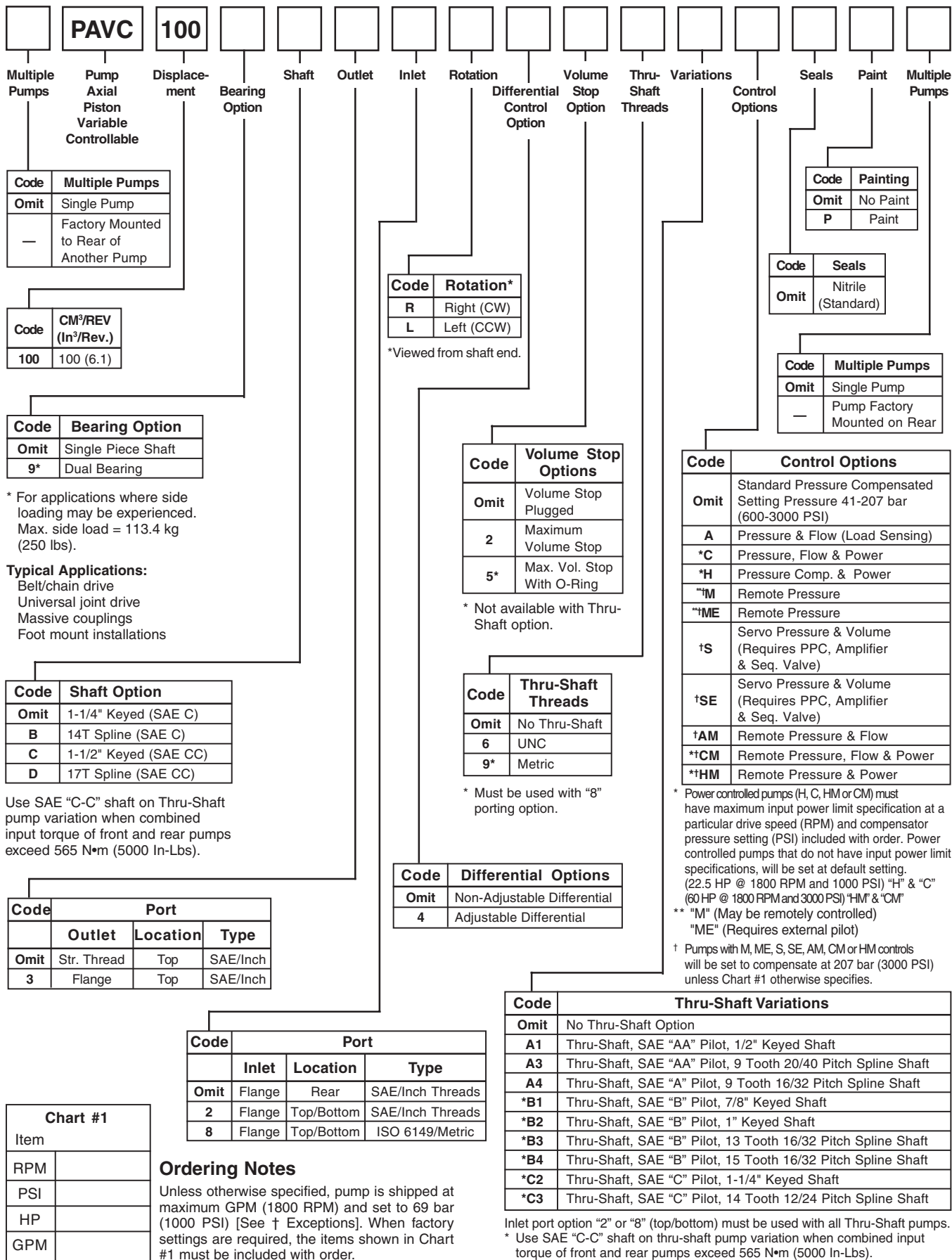

**Ordering Notes**

Unless otherwise specified, pump is shipped at maximum GPM (1800 RPM) and set to 69 bar (1000 PSI) [See † Exceptions]. When factory settings are required, the items shown in Chart #1 must be included with order.

**Typical Performance Data - Fluid: Standard Hydraulic Oil 100 SSU @ 49°C (120°F)**

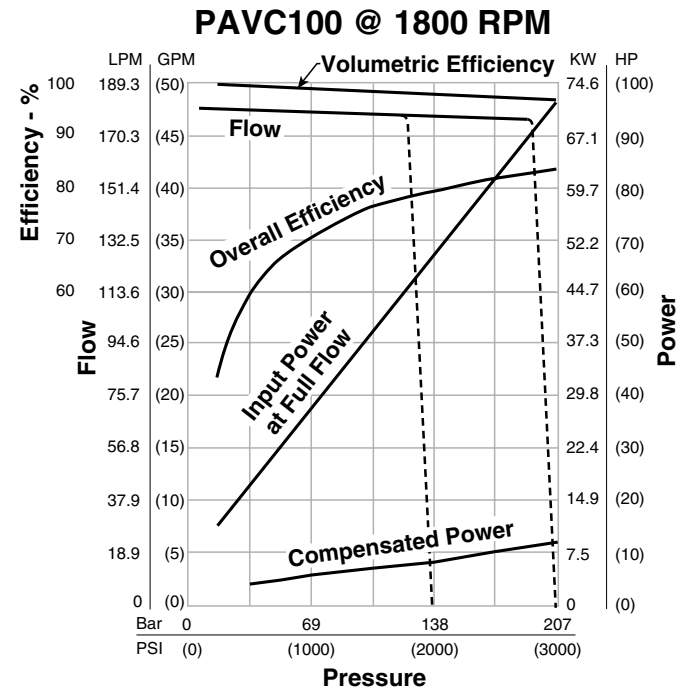
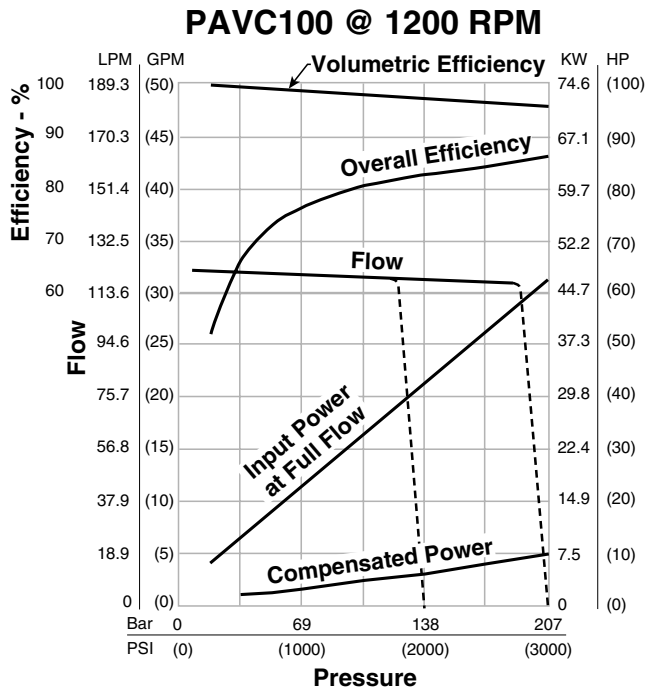

NOTE: The efficiencies and data in the graph are good only for pumps running at 1800 RPM and stroked to maximum. To calculate approximate input power for the other conditions, use the following formula:

$$HP = \left[ \frac{Q \times (PSI)}{1714} \right] + (CHp)$$

WHERE:

- Q = Actual Output Flow in GPM
- PSI = Pressure At Pump Outlet
- CHp = Input Power @ Full Compensation @ 1800 RPM (from graph read at operating pressure)

Actual GPM is directly proportional to drive speed and maximum volume setting. Flow loss, however, is a function of pressure only.

### PAVC100 Inlet Characteristics at Full Displacement (Graph only valid at sea level)

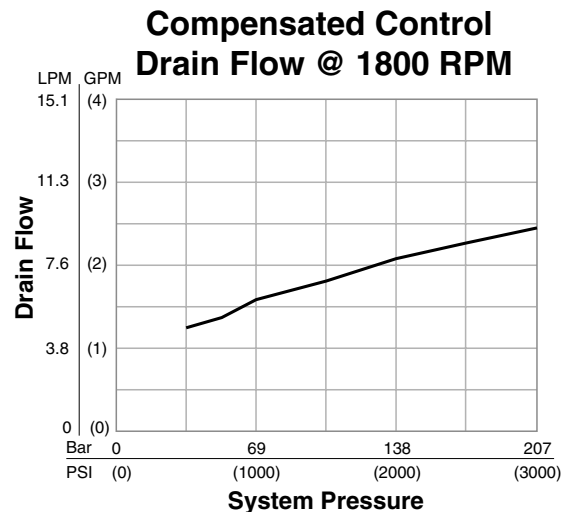
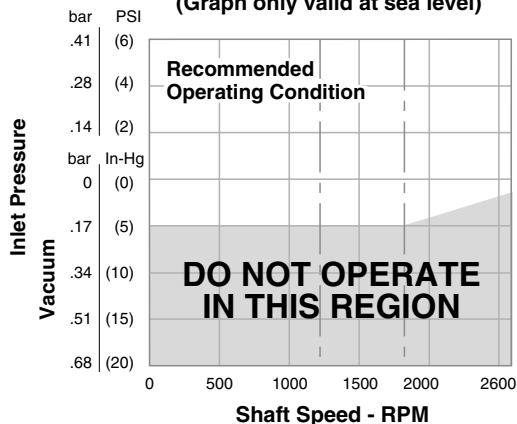

**Typical Performance Data -**

**Minimum Power Settings Attainable  
 With Control Options C, H, CM & HM**

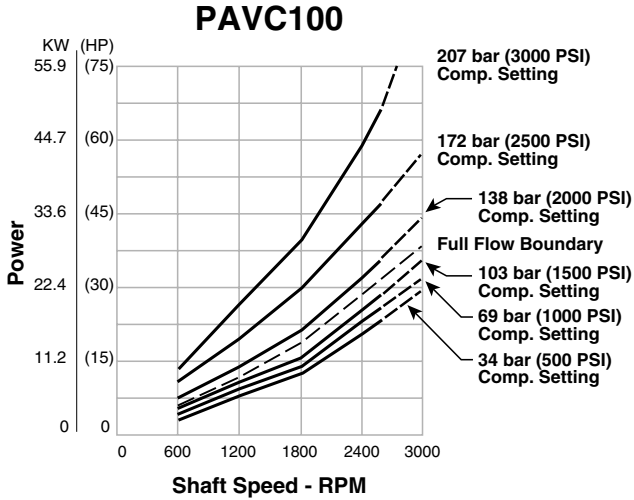

NOTE: Minimum attainable HP setting means that input power will not exceed the indicated setting at the indicated RPM and that the pump will achieve full compensator pressure selected. If setting input power limiter below full flow boundary, full flow may not be obtained at low operating pressure.  
 Determine maximum input power limitation at desired RPM. All points above desired compensator setting curve can be achieved.

**Power (Torque) Limiting Curves**

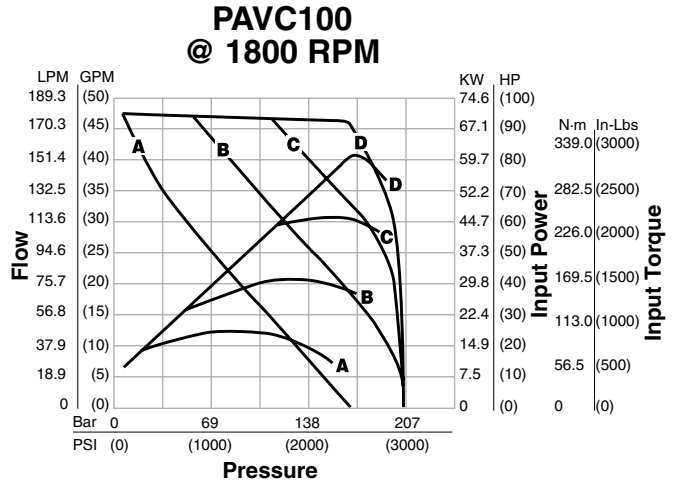
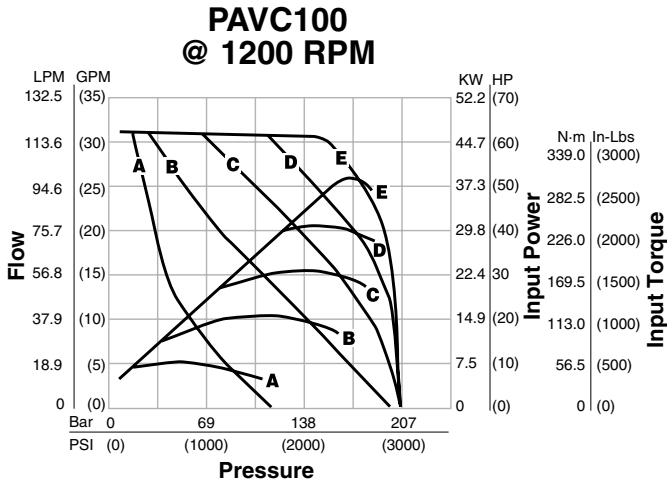

See page 9 for "How to Read Curves" information.

**Dimensional Data**

**Rear Ported Pump Dimensions**

\* Inch equivalents for millimeter dimensions are shown in (\*\*).

**NOTE:**

Pump shown and dimensioned is a clockwise rotation pump. For a counterclockwise rotation pump the outlet port, control drain, signal port and pump controls will be on other side.

Port Location					
Outlet Option	Inlet Option	Outlet Port	Inlet Port	Control Drain	Signal Port
Omit	Omit	SAE-20 Straight Thread (1-5/8-12UNC)	2" SAE 4-Bolt Flange 1/2-13UNC Threads Standard Pressure Series (Code 61)	SAE-6 Straight Thread (9/16-18UNF)	SAE-4 Straight Thread (7/16-20UNF)
3	Omit	1-1/4" SAE Flange 7/16-14UNC Thread Standard Pressure Series (Code 61)	2" SAE 4-Bolt Flange 1/2-13UNC Threads Standard Pressure Series (Code 61)	SAE-6 Straight Thread (9/16-18UNF)	SAE-4 Straight Thread (7/16-20UNF)

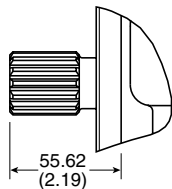

**SHAFT OPTION "B"**  
SAE "C" SPLINE  
14 TOOTH 12/24 DP  
MAX. TORQUE =  
639 N·m (5,680 IN-LBS)

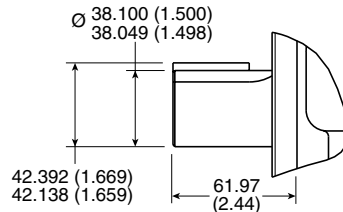

**SHAFT OPTION "C"**  
SAE "C-C" SHAFT  
MAX. TORQUE =  
1,218 N·m (10,780 IN-LBS)

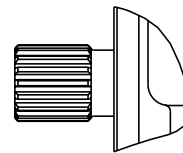

**SHAFT OPTION "D"**  
SAE "C-C" SPLINE  
17 TOOTH 12/24 DP  
MAX. TORQUE =  
1,218 N·m (10,780 IN-LBS)

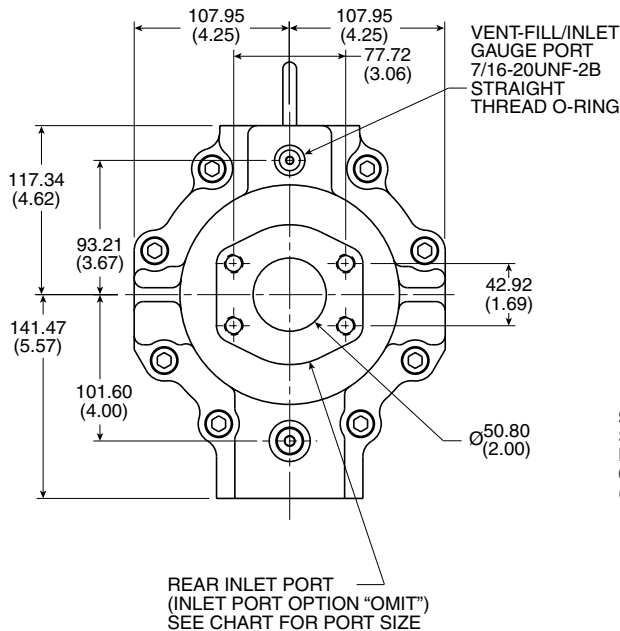

**Rear View**

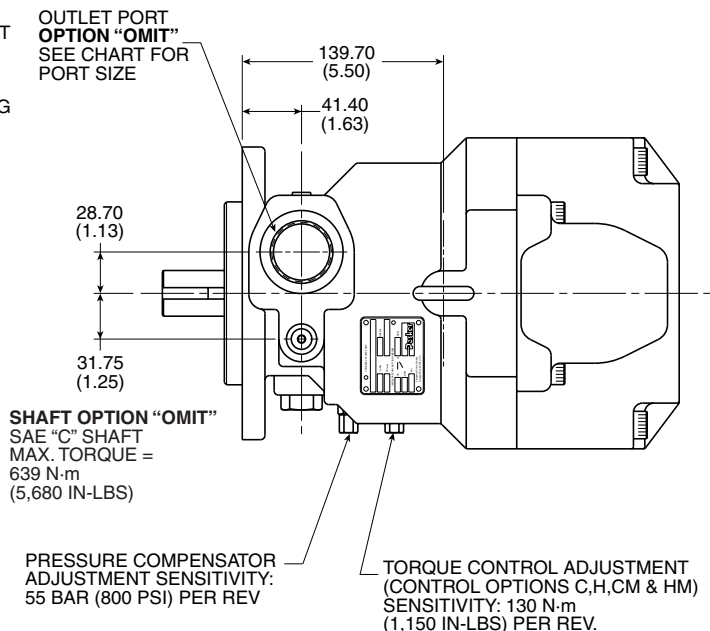

**Top View**



**Dimensional Data**

**Rear Ported Pump Dimensions**

\* Inch equivalents for millimeter dimensions are shown in (\*\*).

**NOTE:**

Pump shown and dimensioned is a clockwise rotation pump. For a counterclockwise rotation pump the outlet port, control drain, signal port and pump controls will be on other side.

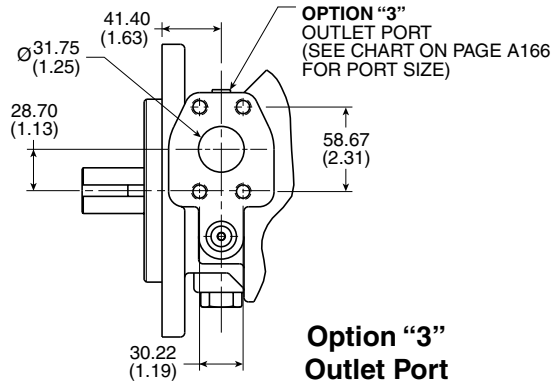

ADAPTABLE TO SAE "C" 2-BOLT MOUNTING OR DIAGONALLY ON SAE "C" 4-BOLT MOUNTING

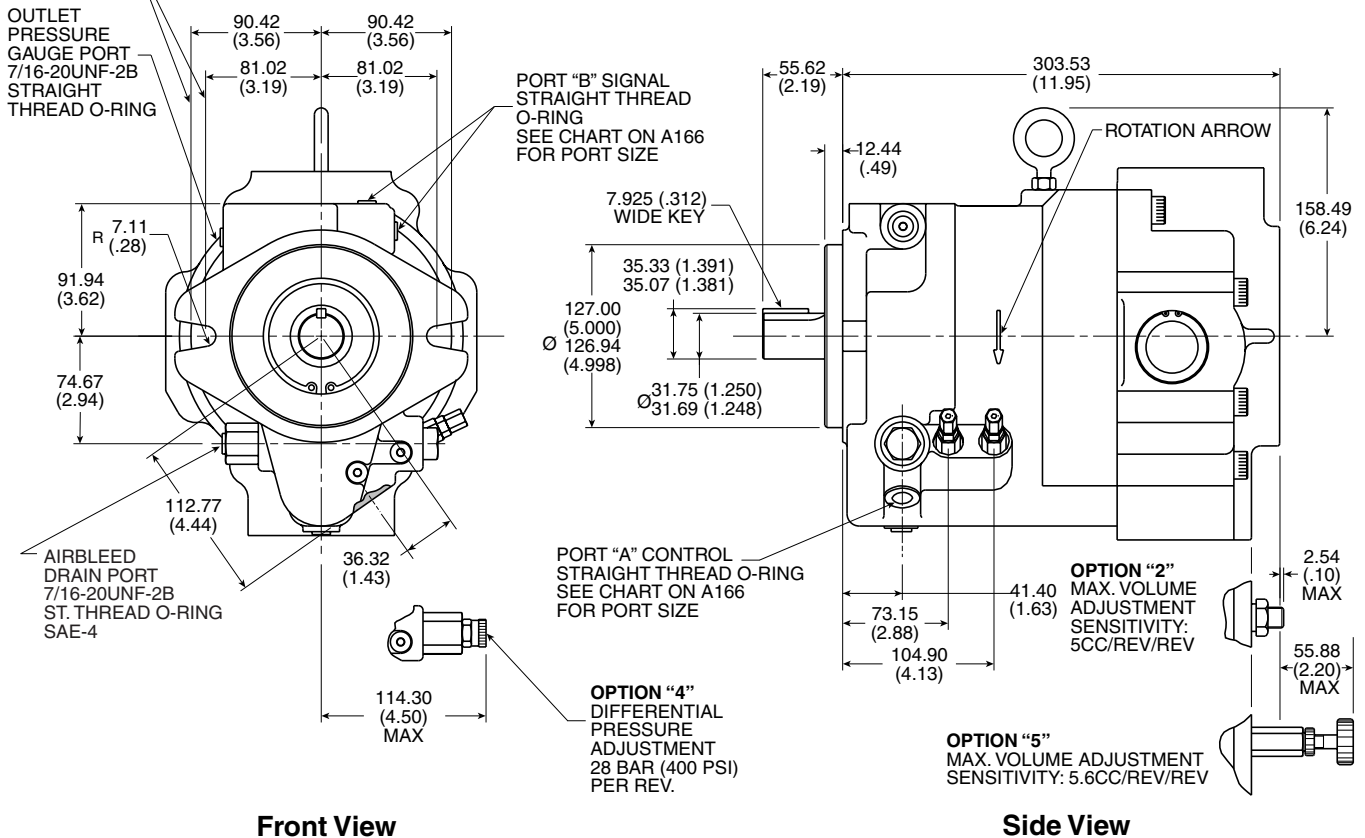

**Dimensional Data**

**Series PAVC100**

**Top/Bottom Ported Pump Dimensions**

\* Inch equivalents for millimeter dimensions are shown in (\*\*).

**NOTES:**

1. Pump shown and dimensioned is a clockwise rotation top/ bottom inlet option pump. For a counterclockwise rotation pump the outlet port, control drain, signal port, and pump controls will be on other side.
2. For other available shafts see page A34.

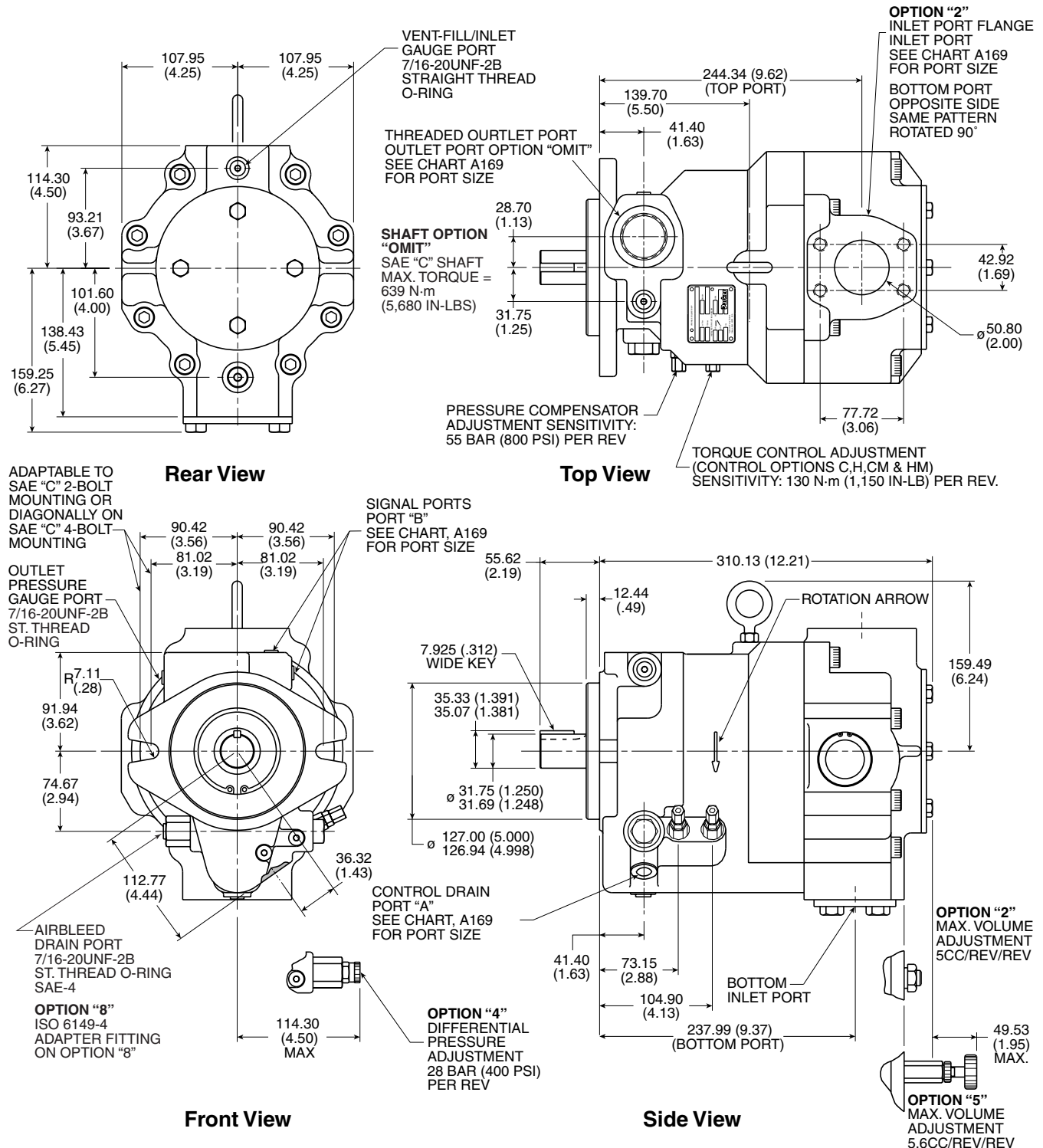

**Dimensional Data**

**Top/Bottom Ported Pump Dimensions**

\* Inch equivalents for millimeter dimensions are shown in (\*\*).

**NOTE:**

Pump shown and dimensioned is a clockwise rotation pump. For a counterclockwise rotation pump the outlet port, control drain, signal port and pump controls will be on other side.

Port Location					
Outlet Option	Inlet Option	Outlet Port	Inlet Port	Control Drain	Signal Port
Omit	2	SAE-20 Straight Thread (1-5/8-12UN)	2" SAE 4-Bolt Flange 1/2-13UNC Threads Standard Pressure Series (Code 61)	SAE-6 Straight Thread (9/16-18UNF)	SAE-4 Straight Thread (7/16-20UNF)
	8	ISO6149-20 Straight Thread (M42 x 2)	2" SAE 4-Bolt Flange M12 x 1.75 Threads Standard Pressure Series (Code 61)	ISO6149-5 Straight Thread (M14 x 1.5)	ISO6149-4 Straight Thread (M12 x 1.5)
3	2	1-1/4" SAE Flange 7/16-14UNC Thread Standard Pressure Series (Code 61)	2" SAE 4-Bolt Flange 1/2-13UNC Threads Standard Pressure Series (Code 61)	SAE-6 Straight Thread (9/16-18UNF)	SAE-4 Straight Thread (7/16-20UNF)
	8	1-1/4" SAE Flange M10 x 1.5 Thread Standard Pressure Series (Code 61)	2" SAE 4-Bolt Flange M12 x 1.75 Threads Standard Pressure Series (Code 61)	ISO6149-5 Straight Thread (M14 x 1.5)	ISO6149-4 Straight Thread (M12 x 1.5)

**Dimensions – Thru-Shaft Options**

\* Inch equivalents for millimeter dimensions are shown in (\*\*).

Variation	A	B	C	D	E	F	G	H
6A1	12.70 (.500)	Ø 50.83/50.85 (2.001/2.002)	82.55 (3.250)	N/A	5/16-18UNC-2B	N/A	Ø 12.70 x 3.175 Key (.500 x .125)	N/A
6A3	12.70 (.500)	Ø 50.83/50.85 (2.001/2.002)	82.55 (3.250)	N/A	5/16-18UNC-2B	N/A	9 Tooth 20/40 Pitch	N/A
6A4	—	Ø 82.58/82.60 (3.251/3.252)	106.38 (4.188)	N/A	3/8-16UNC-2B	N/A	9 Tooth 16/32 Pitch	N/A
6B1	53.98 (2.125)	Ø 101.63/101.65 (4.001/4.002)	146.05 (5.750)	89.81 (3.536)	1/2-13UNC-2B	1/2-13UNC-2B	Ø 22.23 x 6.35 Key (.875 x .250)	△ <sub>2</sub>
6B2	53.98 (2.125)	Ø 101.63/101.65 (4.001/4.002)	146.05 (5.750)	89.81 (3.536)	1/2-13UNC-2B	1/2-13UNC-2B	Ø 25.4 x 6.35 Key (1.000 x .250)	△ <sub>2</sub>
6B3	53.98 (2.125)	Ø 101.63/101.65 (4.001/4.002)	146.05 (5.750)	89.81 (3.536)	1/2-13UNC-2B	1/2-13UNC-2B	13 Tooth 16/32 Pitch	N/A
6B4	53.98 (2.125)	Ø 101.63/101.65 (4.001/4.002)	146.05 (5.750)	89.81 (3.536)	1/2-13UNC-2B	1/2-13UNC-2B	15 Tooth 16/32 Pitch	N/A
6C2	53.98 (2.125)	Ø 127.03/127.05 (5.001/5.002)	180.98 (7.125)	114.50 (4.508)	5/8-11UNC-2B	1/2-13UNC-2B	Ø 31.75 x 7.92 Key (1.250 x .312)	82.55 (3.250)
6C3	53.98 (2.125)	Ø 127.03/127.05 (5.001/5.002)	180.98 (7.125)	114.50 (4.508)	5/8-11UNC-2B	1/2-13UNC-2B	14 Tooth 12/24 Pitch	N/A
9A1	12.70 (.500)	Ø 50.83/50.85 (2.001/2.002)	82.55 (3.250)	N/A	M8 x 1.25	N/A	Ø 12.70 x 3.175 Key (.500 x .125)	N/A
9A3	12.70 (.500)	Ø 50.83/50.85 (2.001/2.002)	82.55 (3.250)	N/A	M8 x 1.25	N/A	9 Tooth 20/40 Pitch	N/A
9A4	—	Ø 82.58/82.60 (3.251/3.252)	106.38 (4.188)	N/A	M10 x 1.50	N/A	9 Tooth 16/32 Pitch	N/A
9B1	53.98 (2.125)	Ø 101.63/101.65 (4.001/4.002)	146.05 (5.750)	89.81 (3.536)	M12 x 1.75	M12 x 1.75	Ø 22.23 x 6.35 Key (.875 x .250)	△ <sub>2</sub>
9B2	53.98 (2.125)	Ø 101.63/101.65 (4.001/4.002)	146.05 (5.750)	89.81 (3.536)	M12 x 1.75	M12 x 1.75	Ø 25.4 x 6.35 Key (1.000 x .250)	△ <sub>2</sub>
9B3	53.98 (2.125)	Ø 101.63/101.65 (4.001/4.002)	146.05 (5.750)	89.81 (3.536)	M12 x 1.75	M12 x 1.75	13 Tooth 16/32 Pitch	N/A
9B4	53.98 (2.125)	Ø 101.63/101.65 (4.001/4.002)	146.05 (5.750)	89.81 (3.536)	M12 x 1.75	M12 x 1.75	15 Tooth 16/32 Pitch	N/A
9C2	53.98 (2.125)	Ø 127.03/127.05 (5.001/5.002)	180.98 (7.125)	114.50 (4.508)	M16 x 2	M12 x 1.75	Ø 31.75 x 7.92 Key (1.250 x .312)	82.55 (3.250)
9C3	53.98 (2.125)	Ø 127.03/127.05 (5.001/5.002)	180.98 (7.125)	114.50 (4.508)	M16 x 2	M12 x 1.75	14 Tooth 12/24 Pitch	N/A

△<sub>2</sub> 88.90 (3.500) for pumps with shaft lengths between 53.34 (2.10) and 58.67 (2.31) inches.  
76.20 (3.000) for pumps with shaft lengths between 40.64 (1.60) and 45.72 (1.80) inches.

**Thru-Shaft Options – Dimensions**

\* Inch equivalents for millimeter dimensions are shown in (\*\*).

**NOTES:**

1. Rear adapters may be rotated 90°.
2. Pump shown is a clockwise rotation pump. For a counterclockwise pump the outlet port, control drain and control adjustments will be on opposite side.
3. Maximum torque transmitting capacity for rear mounting of pumps is 639 N•m (5,680 In. Lbs). Lower allowables may apply based on pump mounted on rear.

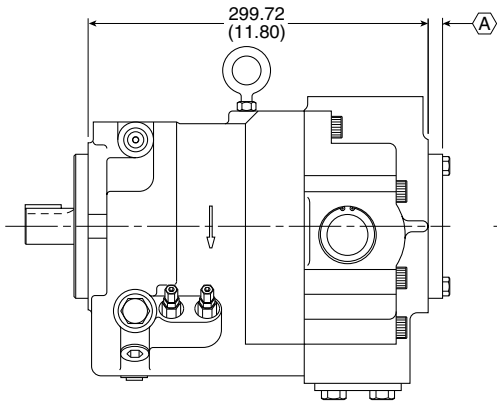

**Side View**

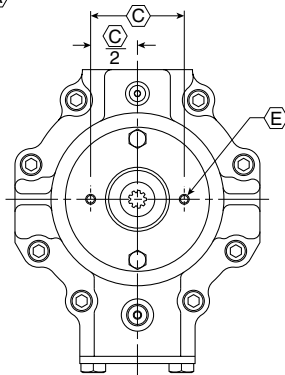

**Rear View**

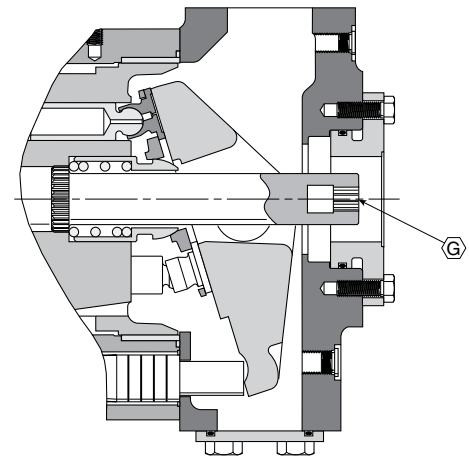

**Variations 6A\* & 9A\***

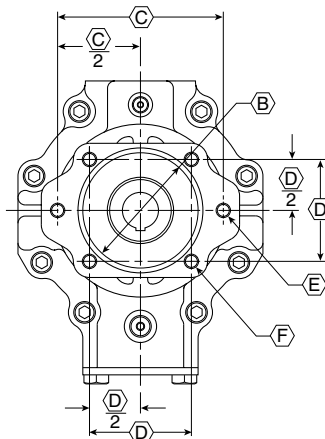

**Rear View**

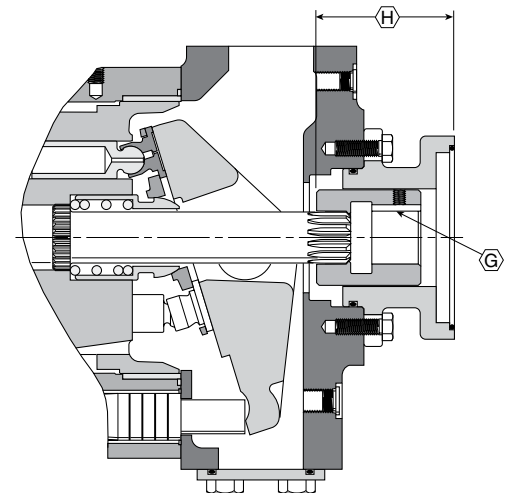

**Variations 6B\* & 6C\*  
 9B\* & 9C\***

**Electrohydraulic Pump Dimensions**

\* Inch equivalents for millimeter dimensions are shown in (\*\*).

**NOTE:** Reference "Electrohydraulic Accessories" Catalog 2600-400-1 for more complete information.

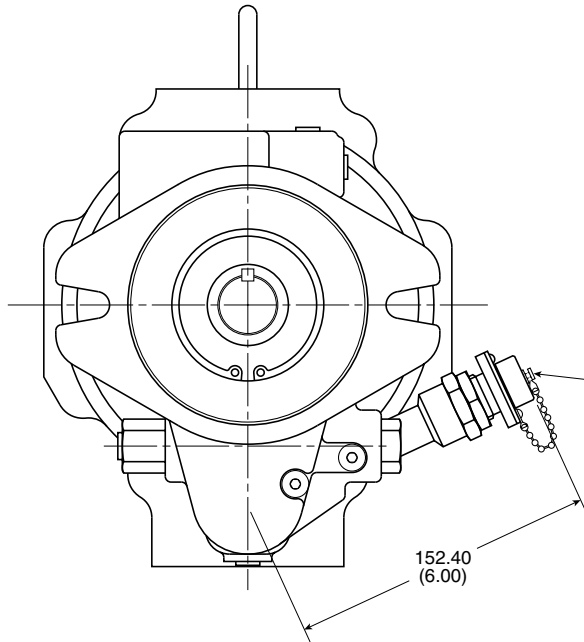

FEEDBACK CONNECTOR MS3102R14S-2PY  
 MATES WITH MS3106A14S-2SY  
 (PART NO. 800722)

ELECTROHYDRAULIC CABLE CAN BE  
 ORDERED AS EHC\*4Y\*

Accessories for S & SE Options	
PPC Valve (2500 PSI)	694586
PPC Valve (3000 PSI)	786645
Amp Single Pump	AP11
Amp Double Pump	AP211
Seq. Valve [227 LPM (40 GPM) Max.]	SX6PM8, SX6MM8 (Inline) (Manifold)
Seq. Valve [340 LPM (90 GPM) Max.]	SX10PM8, SX10MM8 (Inline) (Manifold)
Electrohydraulic Cable [Pump to Amp]	EHC*4YB
Electrohydraulic Cable [PPC to Amp]	EHC*2AB

\* = Length in Feet

**NOTES:**

1. Consult factory for information relative to pump option selection and additional components required for desired pump function.
2. For electrohydraulic flow and pressure control of one or two pumps, make electrical connections per Figure IV. When one pump is used, omit connections to pump #2 feedback.
3. For electrohydraulic flow only, eliminate pressure command signal and place jumper between "Press CMD" and "+10V" terminals (compensating pressure will be controlled by maximum setting on pump or remote compensator if used).
4. For electrohydraulic pressure only, eliminate volume command signal and place jumper between "VOL CMD" and "+10V" terminals or use 801179 pressure driver card.
5. Figures I thru III show nominal input vs. output relationships. The actual values will vary with component tolerances. Full volume range will be realized with 0 to 7 volts. Full pressure range will be realized with 0 to 7 volts, or 0-500MA.
6. Pump shown is a clockwise rotation. For a counterclockwise rotation LVDT feedback is on opposite side.
7. For further detail on installation of AP11/AP211, refer to the latest edition of Catalog 2600-400-x/US.

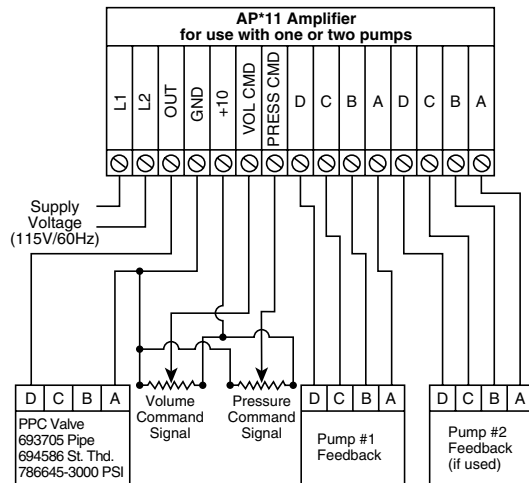

Typical hookup for infinitely variable electrohydraulic pressure & volume control.

**Fig. IV**

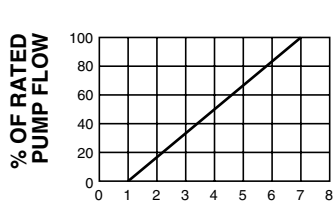

**Volume Command Voltage**

Nominal output flow vs. input command voltage when used in conjunction with AP\*11 amplifier and 786645 proportional pressure controller.

**Fig. I**

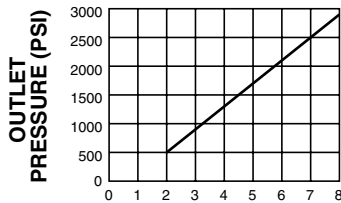

**Pressure Command Voltage**

Nominal output pressure vs. input command voltage when used in conjunction with AP\*11 amplifier and 786645 proportional pressure controller.

**Fig. II**

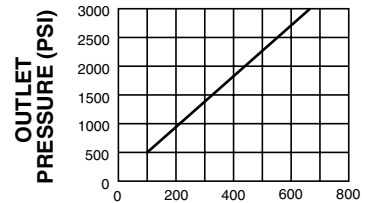

**Input Current (MA)**

Nominal input current vs. pressure when used in conjunction with a current source and 786645 proportional pressure controller.

**Fig. III**

**Generic Pump Assembly**

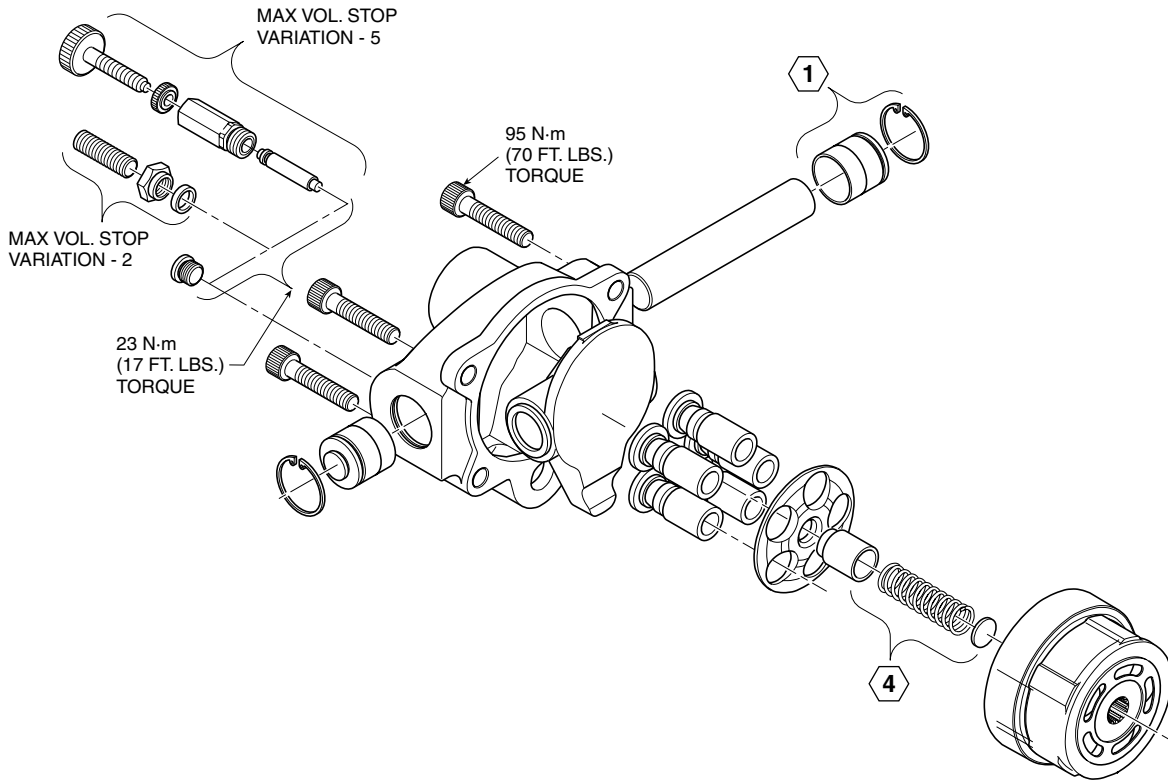

<p><b>1 TRUNNION CAP ASSEMBLY</b></p> <p>THRUST WASHER (Not on PAVC100)</p> <p>SNAP RING</p> <p>O-RING</p> <p>TRUNNION CAP</p> <p>ROLLER BEARING</p>	<p><b>4 RETAINER DETAIL</b></p>	<p><b>7 AIR BLEED ASSEMBLY</b></p> <p>BODY</p> <p>SPRING</p> <p>BALL</p> <p>STAKE BALL IN PLACE</p>
<p><b>2 SLEEVE ASSEMBLY</b></p> <p>SLEEVE</p> <p>O-RING 1</p> <p>BACK-UP RING 2</p>	<p><b>5 BEARING SHAFT ASSEMBLY</b></p>	<p><b>8 ADJUSTING STEM ASSEMBLY</b></p> <p>PLUG</p> <p>STEM</p> <p>O-RING 1</p> <p>BACK-UP RING 2</p>
<p><b>3 PLUG ASSEMBLY</b></p> <p>SLEEVE</p> <p>O-RING 1</p> <p>BACK-UP RING 2</p>	<p><b>6 PISTON - DIFFERENTIAL CONTROL</b></p> <p>PISTON BODY</p> <p>O-RING 1</p> <p>BACK-UP RING 2</p>	<p><b>9 PORT PLATE</b></p> <p>LEFT HAND (CCW) PORT PLATE SHOWN IN ASSEMBLY (ABOVE).          RIGHT HAND (CW) PORT PLATE SHOWN BELOW.</p>



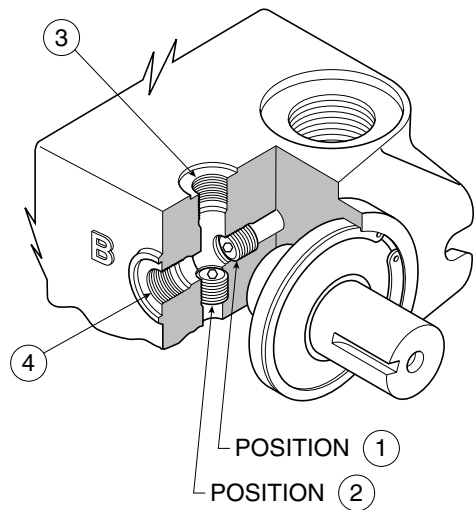
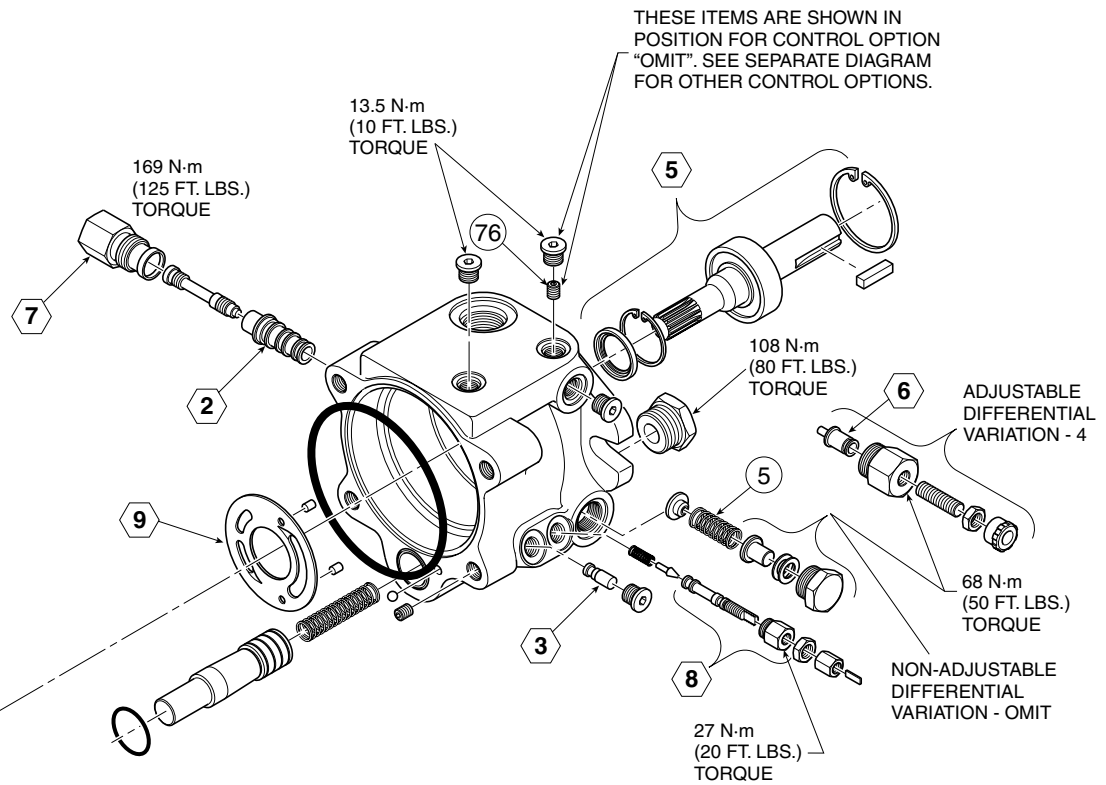

⑩ TORQUE (HP) CONTROL (See next page)

⑪ VOLUME SERVO FEEDBACK (See next page)

**Part Number Description**

102 x 1	Solid Pipe Plug (1/16")
108 x 4	SAE Plug - 4
690870	.028 Orifice Plug (1/16")
800599	.034 Orifice Plug (1/16")
786635	.034 Orifice Fitting
787474	Upstroke Spring

**PAVC 33, 38, 65**

	Position				
Control Option	①	②	③	④	⑤
Omit	Open	800599	108 x 4	108 x 4	Omit
A	102 x 1	800599	Open	108 x 4	787474*
C	102 x 1	800599	Open	108 x 4	787474*
H	Open	800599	108 x 4	108 x 4	Omit
M	800599	Open	Open	108 x 4	Omit
ME	102 x 1	800599	Open	108 x 4	787474*
S	800599	Open	Open	108 x 4	Omit
SE	102 x 1	800599	Open	108 x 4	Omit
AM	102 x 1	800599	786635	Open	787474*
CM	102 x 1	800599	786635	Open	787474*
HM	800599	Open	Open	108 x 4	Omit

\* Available Only on PAVC65.

**PAVC100**

	Position				
Control Option	①	②	③	④	⑤ <sup>‡</sup>
Omit	Open	690870	108 x 4	108 x 4	787474
A	102 x 1	690870	Open	108 x 4	787474
C	102 x 1	690870	Open	108 x 4	787474
H	Open	690870	108 x 4	108 x 4	787474
M	690870	Open	Open	108 x 4	787474
ME	102 x 1	690870	Open	108 x 4	787474
S	690870	Open	Open	108 x 4	787474
SE	102 x 1	690870	Open	108 x 4	787474
AM	102 x 1	690870	786635	Open	787474
CM	102 x 1	690870	786635	Open	787474
HM	690870	Open	Open	108 x 4	787474

<sup>‡</sup> 787474 is always included with the PAVC100.

**10 CONTROL OPTION "C" & "H"**  
**PRESSURE, POWER & FLOW**

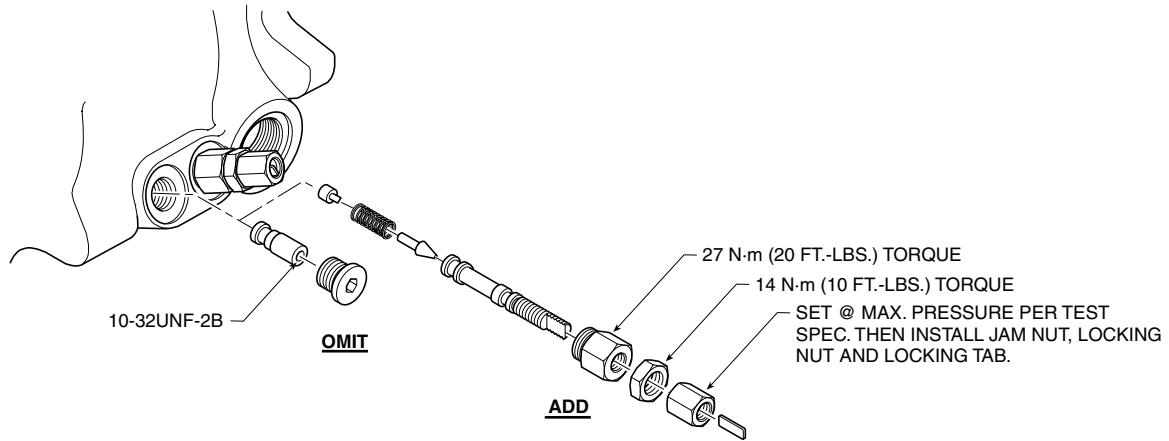

**11 CONTROL OPTION "S" & "SE"**  
**SERVO VOLUME FEEDBACK**

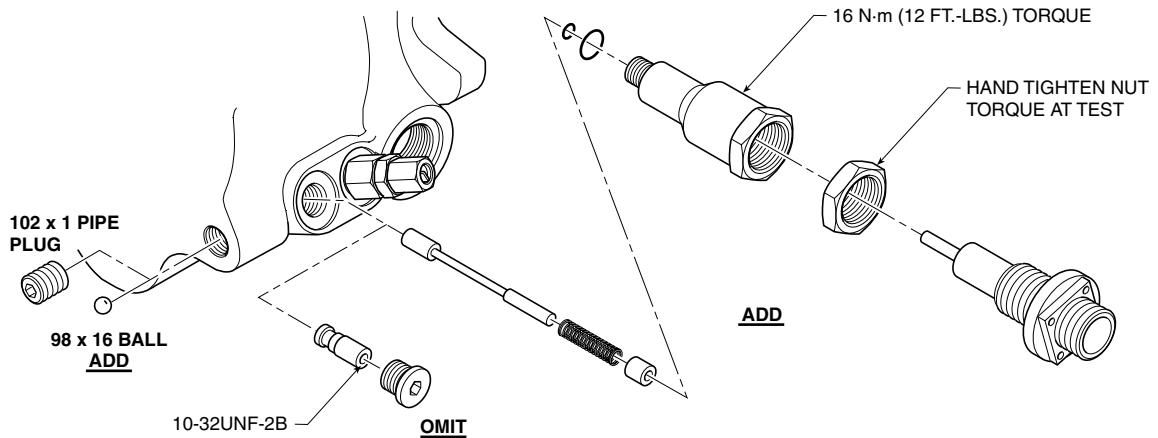

**NOTE:** Install ball through torque port, seat in place through bolt hole.

**SERVO VOLUME ASSEMBLY**

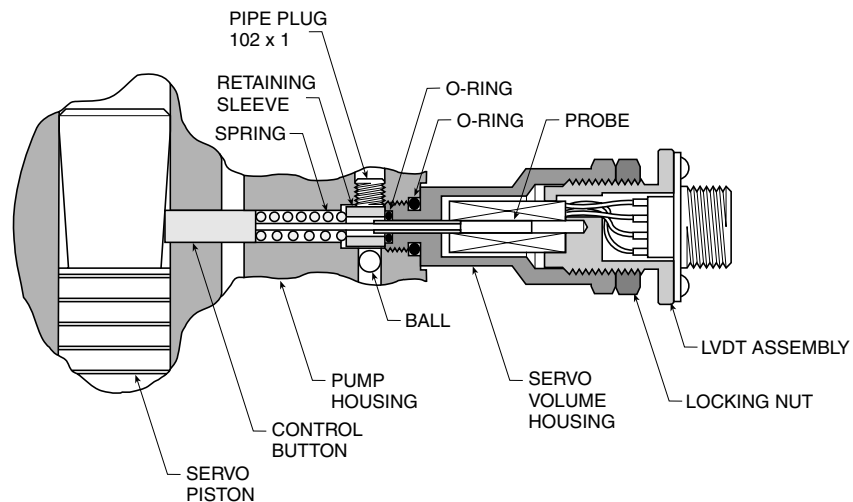

# Additional PAVC Options

Consult factory for more information.

**Non-Standard Shaft and Pilot Options - PAVC65**

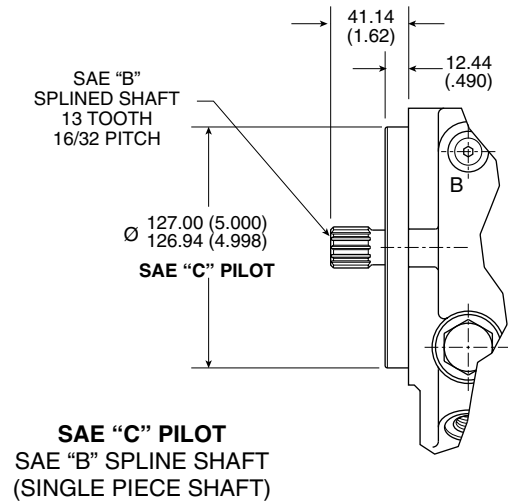
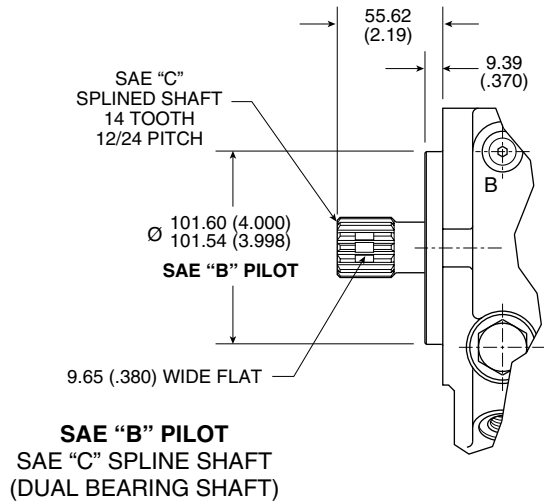
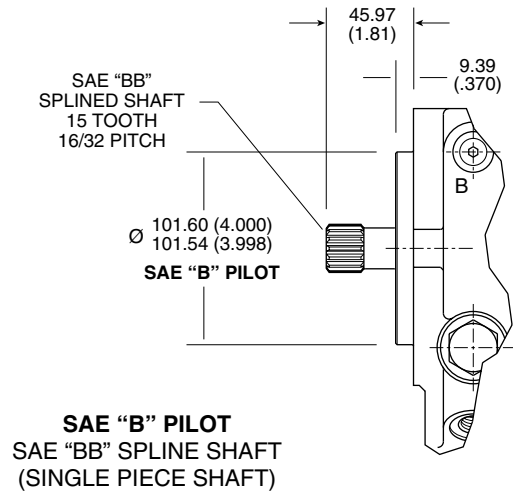
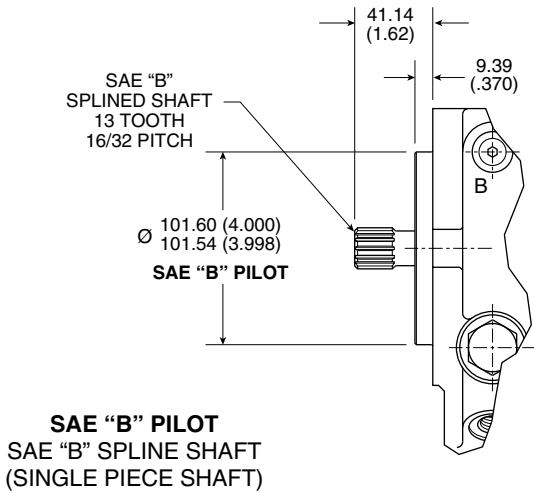

**Non-Standard Shaft and Pilot Option - PAVC100**

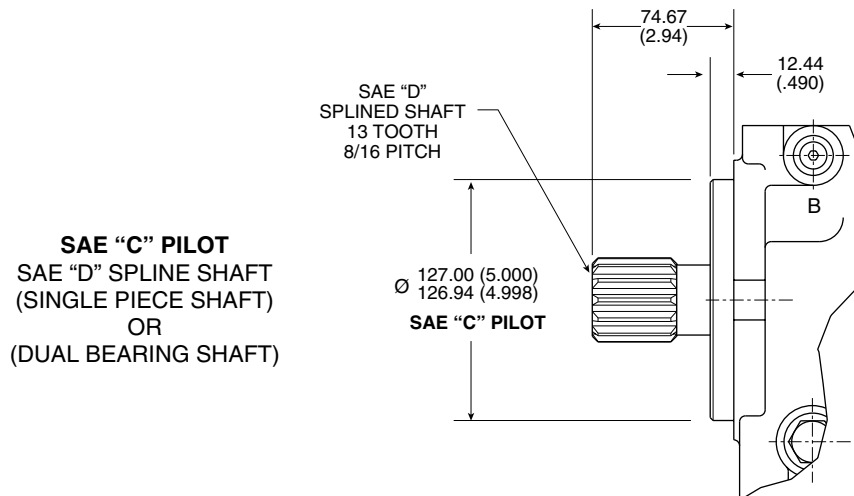

**Harsh Environment Seal Option**

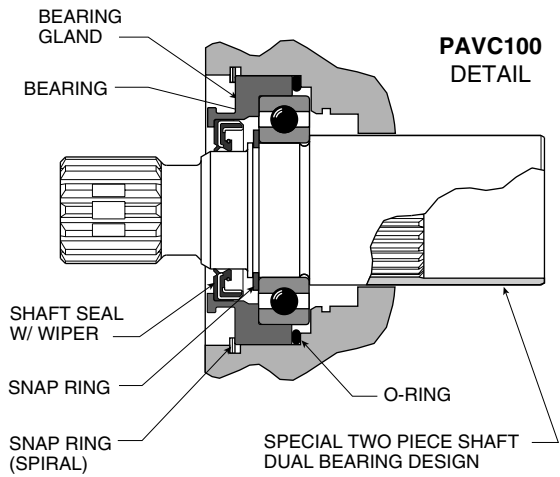
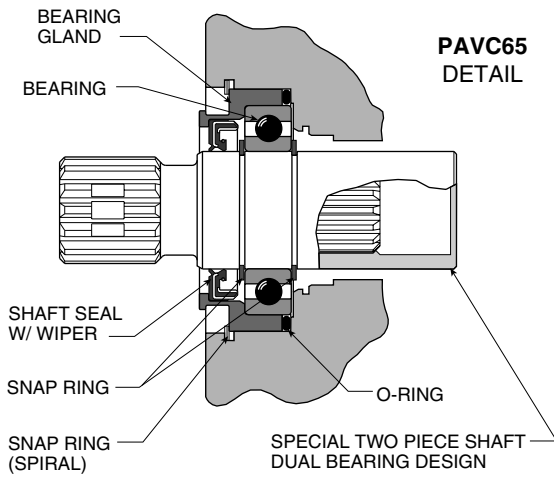

**PAVC65 - Harsh Environment-Shaft and Pilot Configurations**

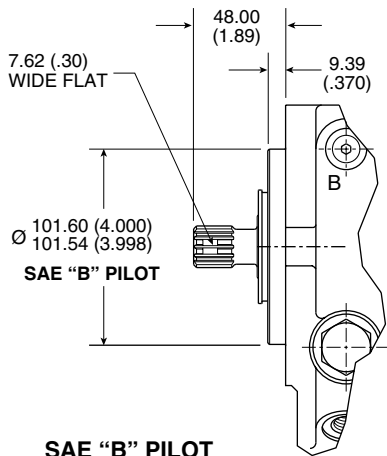

**SAE "B" PILOT**  
 SAE "B" SPLINE SHAFT  
 13 TOOTH, 16/32 D.P.

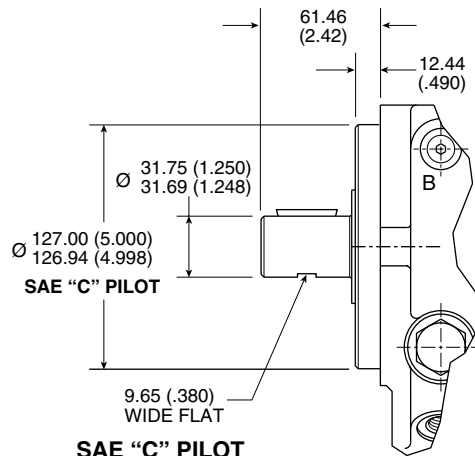

**SAE "C" PILOT**  
 1-1/4" (31.75) DIA.  
 5/16" (7.9) KEYED SHAFT

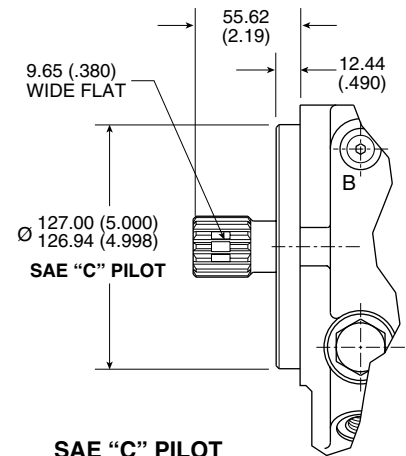

**SAE "C" PILOT**  
 SAE "C" SPLINE SHAFT  
 14 TOOTH, 12/24 D.P.

**PAVC100 - Harsh Environment-Shaft and Pilot Configurations**

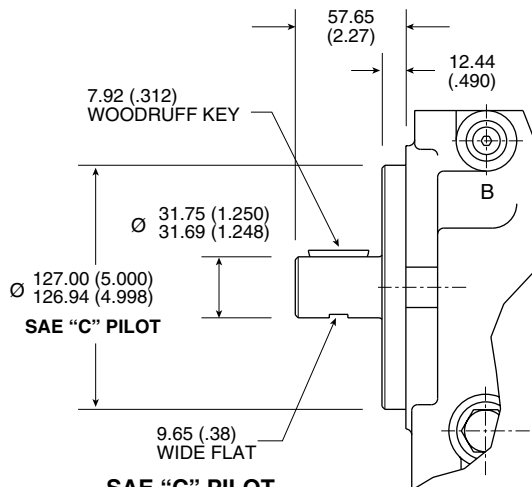

**SAE "C" PILOT**  
 1-1/4" (31.75) DIA.  
 5/16" (7.9) KEYED SHAFT

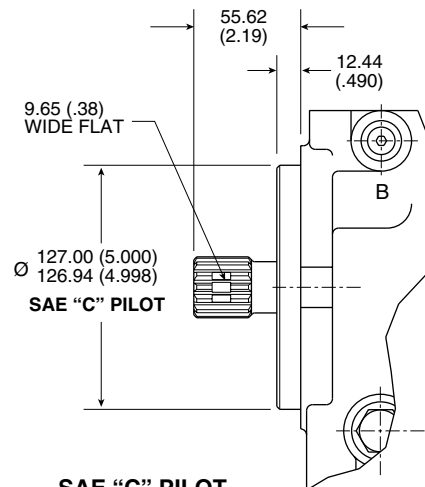

**SAE "C" PILOT**  
 SAE "C" SPLINE SHAFT  
 14 TOOTH, 12/24 D.P.

**Sculptured Housings - PAVC65**

**NOTE:**

There are many sculptured housings and special porting configurations for applications where the standard PAVC has interference. Consult factory.

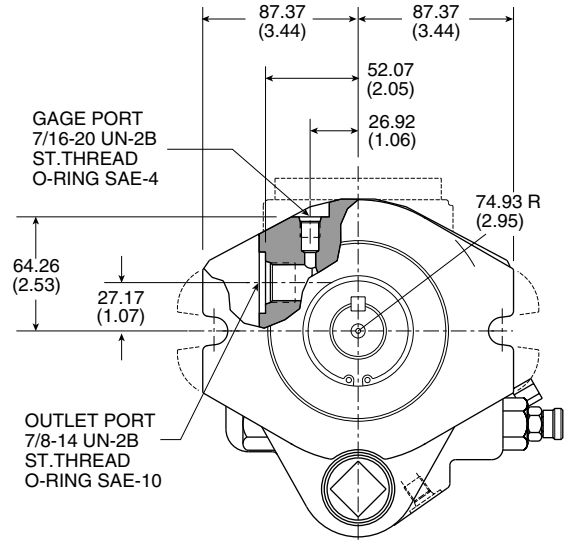
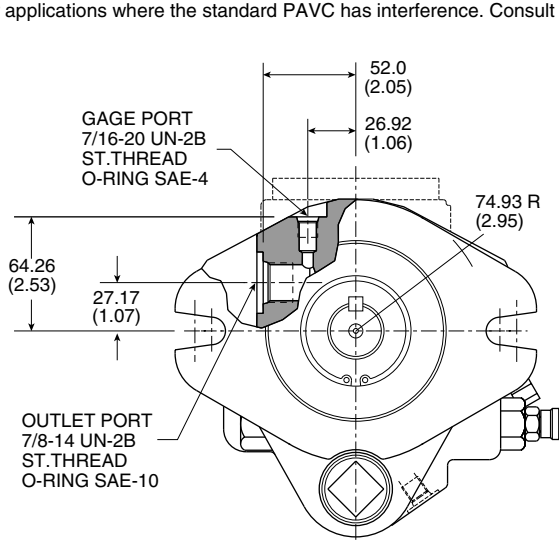

**Special (Dual) Inlet - PAVC65**

Top Port: 1-1/2" SAE Flange  
 Rear Port: SAE-24 O-Ring

**NOTE:**

Dual inlet recommended in applications where pump operating speed exceeds 2700 RPM without inlet precharge pressure.

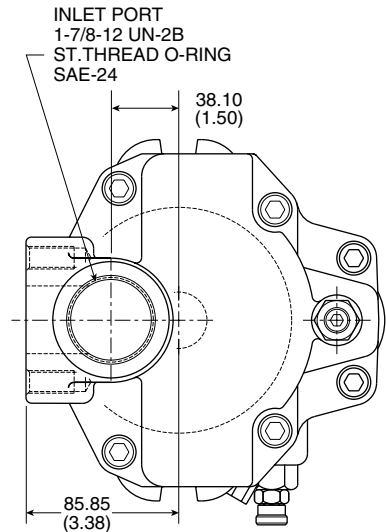
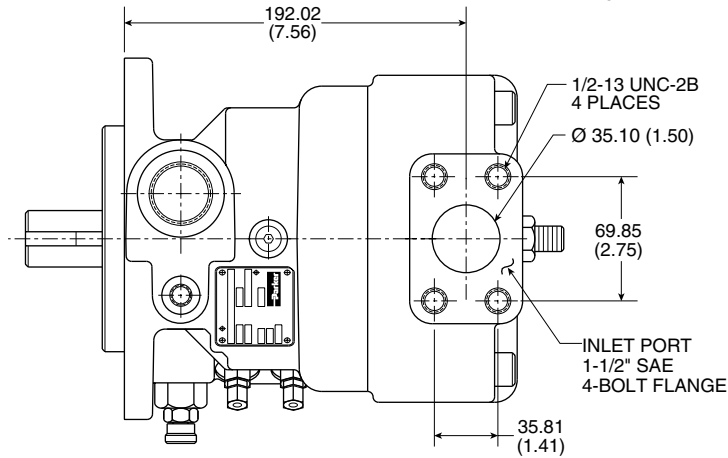

**Special (Top) Inlet - PAVC65**

Top Port: SAE-24 O-Ring

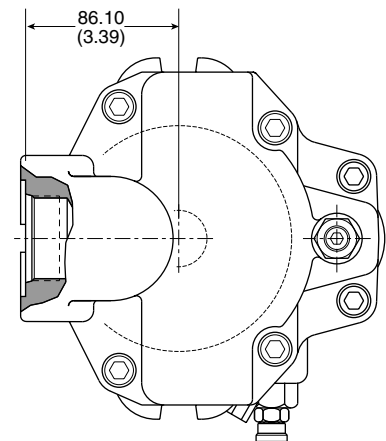
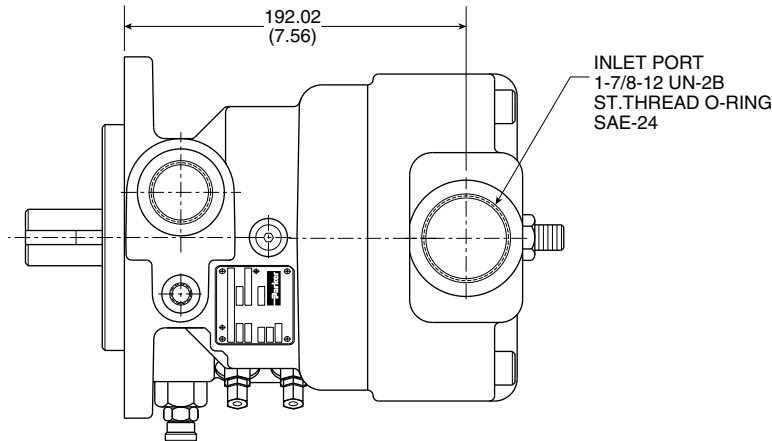

**Transmission Spacer**

SAE "B" Pilot

**NOTE:** Spacer mounts on pilot of pump in order to move the pump away from transmission when there is an interference problem. Consult factory.

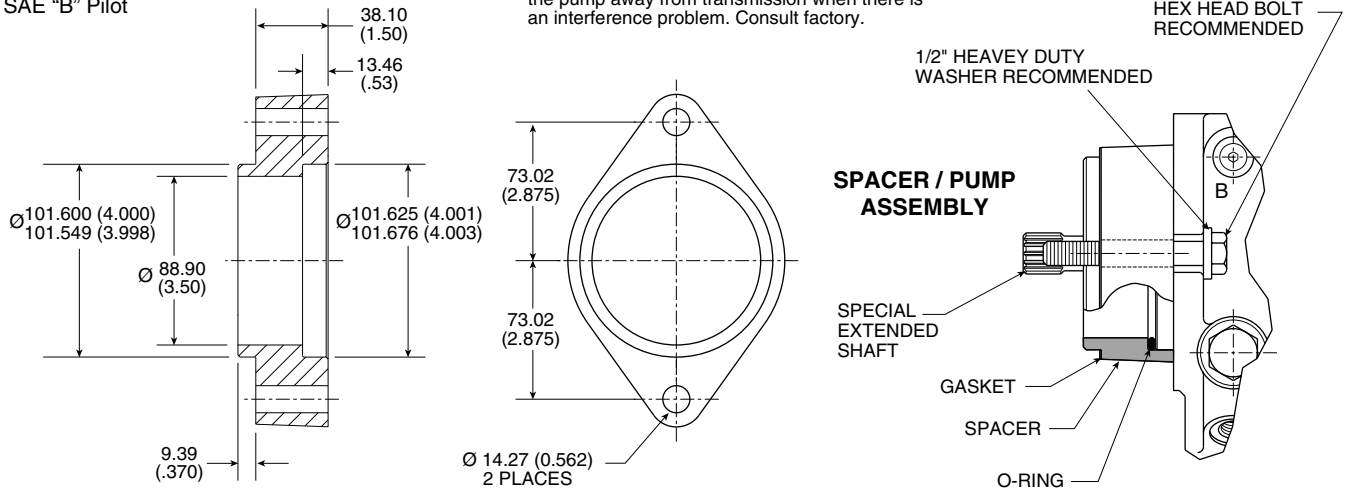

**Speed Pickup**

PAVC 33, 38, 65

**NOTE:** PAVC65 Shown

**NOTE:** The speed pick-up option is a provision for a speed sensor to read off the flutes on the barrel. Consult factory.

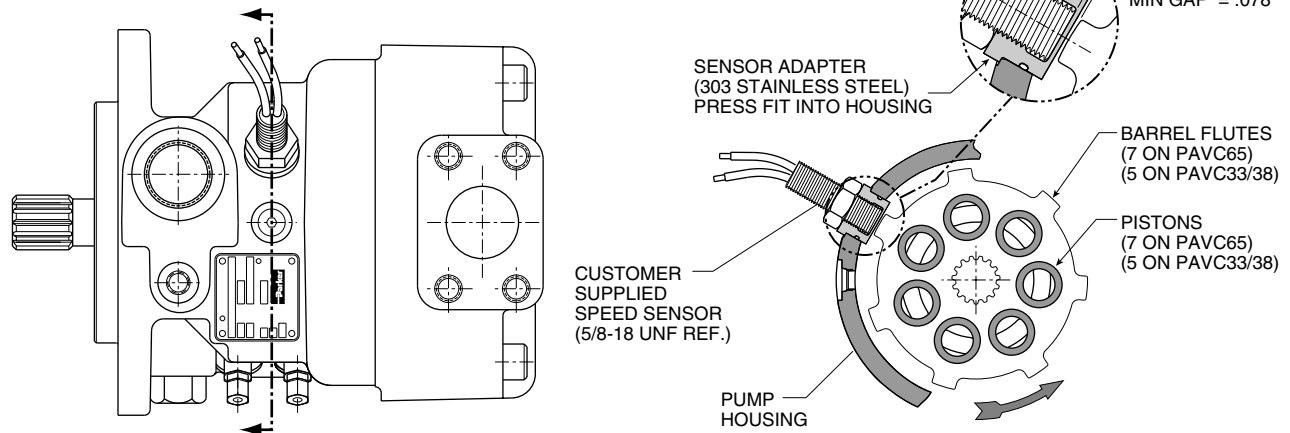

**Pump Enable**

**NOTE:** The pump enable option allows the pump to go lower than catalog low-pressure standby setting. Consult factory.

**PAVC65**

AVAILABLE WITH ENABLE SOLENOID BOLTED TO PUMP

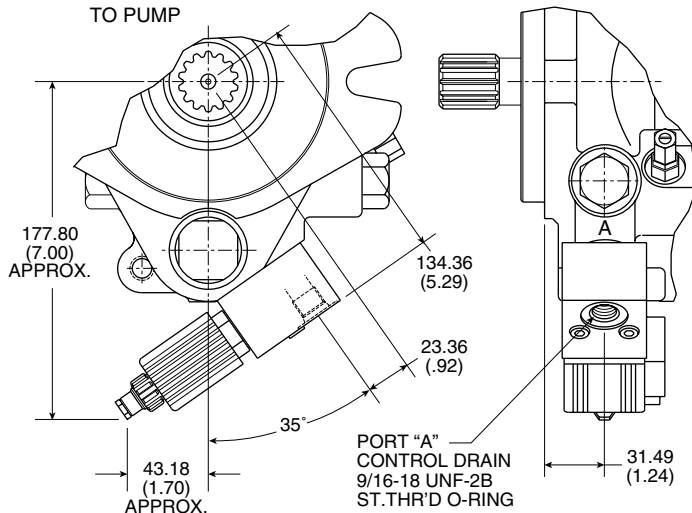

**PAVC33/38**  
 EXTERNAL CONTROL ONLY

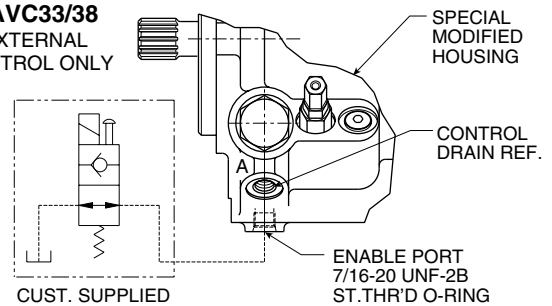

**PAVC100**  
 EXTERNAL CONTROL ONLY

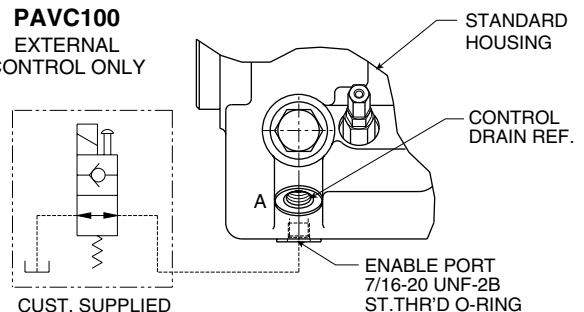



### Use Of A Relief Valve

The use of a relief valve, while not mandatory is recommended in the main circuit to suppress hydraulic shock loads and additional system protection. If a minimum volume stop is used, the use of a relief valve is mandatory.

### Fluid Recommendations

Premium quality hydraulic oil with a viscosity range between 150-250 SSU (30-50 cst.) at 38°C (100°F). Normal operating viscosity range between 80-1000 SSU (17-180 cst.). Maximum start-up viscosity is 4000 SSU (1000 cst.).

NOTE: Consult Parker when exceeding 71°C (160°F) operation. Oil should have maximum anti-wear properties, rust and oxidation treatment.

### Filtration

For maximum pump and system component life, the system should be protected from contamination at a level not to exceed 125 particles greater than 10 microns per milliliter of fluid. (SAE Class 4/ISO 16/13). Due to the nature of variable displacement pumps, variations in pump inlet conditions, fluid acceleration losses, system aeration, and duty cycle we do not recommend suction line filters. We do recommend the use of a properly sized, in-tank suction strainer. Contact your Parker representative for assistance.

### Start-Up

On initial start-up, the case should be filled with oil, pressure should be reduced and the circuit should be open or the air bled from the pump outlet to permit priming. Use of the airbleed is recommended on initial start-up. See Installation and Mounting Section to connect airbleed.

### Inlet Conditions

Not to exceed .17 bar (5 In. Hg.). Vacuum at 1800 RPM on petroleum base fluids. See recommended speed spectrum for specific inlet conditions.

### Shaft Rotation and Line Up

Pump and motor shaft alignment must be within .010 TIR maximum, using a standard floating coupling. Please follow coupling manufacturer's recommended installation instructions to prevent end thrust on pump shaft. Turn pump to assure freedom of rotation. Pump and motor must be on a rigid base.

The coupling should be sized to absorb the peak horsepower developed.

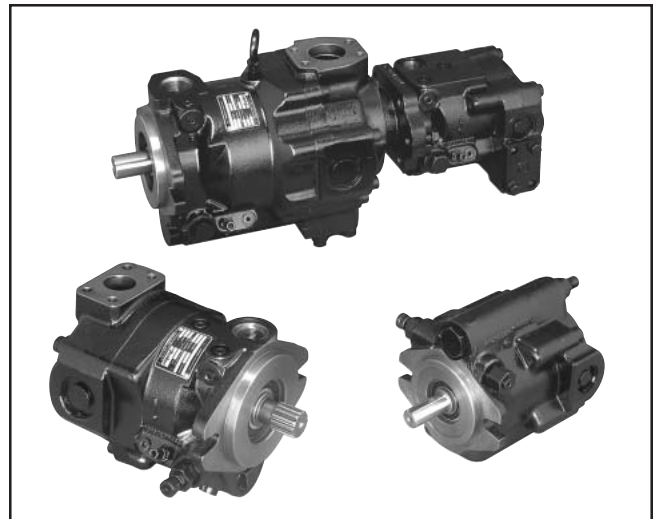

### Installation and Mounting

When a PAVC Series Pump is mounted above the fluid level, the position of the "control drain" is not restricted but **the inlet port should not be on the bottom (PAVC100)**. When a PAVC Series Pump is mounted below the fluid level the position of all ports are not restricted. The "control drain" should be a separate line to the reservoir and extend below the oil level as far from the inlet line as possible. The "control drain" line can be filtered and/or cooled (must not exceed 7 bar (100 PSI) back pressure). Suggested maximum line length is 10 feet.

A built in airbleed is standard on all PAVC 33, 38, 65 and 100 Pumps. To connect, remove airbleed drain plug and connect a line unrestricted to reservoir extending below minimum oil level. Back pressure in this line must not exceed .28 bar (4 PSI).

### Special Installations

Consult your Parker representative for any application requiring the following:

Pressure above rated, drive speed above maximum, indirect drive, fluid other than petroleum oil, oil temperature above 71°C (160°F).

### Inlet Pressure

Not to exceed 1.72 bar (25 PSI).